

INSTALLATION MANUAL

R-410A AFFINITY™ SERIES

DNQ024-060

2-5 Ton

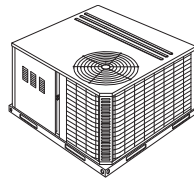

ISO 9001
Certified Quality
Management System

TABLE OF CONTENTS

General	1	Phasing	15
Installation	3	Gas Heat	15
Limitations	3	Flue Vent Hood	16
Location	5	Airflow Performance	18
Rigging And Handling	5	Blower Speed Selection	25
Ductwork	9	Operation	25
Roof Curb	9	Heating Sequence Of Operation	25
Filters	9	Cooling Sequence Of Operations	27
Condensate Drain	10	Start-Up	28
Service Access	10	Adjustment of Temperature Rise	30
Thermostat	10	Checking Gas Heat Input	30
Power And Control Wiring	10	Natural Gas	30
Compressors	15	Typical Wiring Diagrams	31

LIST OF TABLES

1 Unit Limitations	4	12 Natural Gas Application Data-Two Stage	17
2 Weights and Dimensions	6	13 Propane (LP) Gas Application Data-Single Stage	17
3 Unit Accessory Weights	6	14 Propane (LP) Gas Application Data-Two Stage	17
4 Unit Dimensions Front	7	15 Side Duct Application	18
5 Unit Clearances	7	16 Bottom Duct Application	21
6 Electrical Data	12	17 Additional Static Resistance	24
7 Single Stage Physical Data	13	18 Indoor Blower Specifications	25
8 Two Stage Physical Data	14	19 Delay Profile	25
9 Natural Gas Pipe Sizing Chart	16	20 Ignition Control Board Flash Codes	27
10 Propane (LP) Gas Pipe Sizing Chart	16	21 Gas Rate Cubic Feet Per Hour	30
11 Natural Gas Application Data-Single Stage	17		

LIST OF FIGURES

1 Component Location	4	10 Typical Field Power Wiring Diagram	12
2 Unit 4 Point Load Weight	6	11 External Supply Connection External Shut-Off	15
3 Unit Dimensions	7	12 Flue Vent Outlet Air Hood	16
4 Dimensions Front and Bottom	8	13 Control Board Speed Tap Location	25
5 Dimensions Back and Bottom	8	14 Single Stage Gas Valve Front	29
6 Roof Curb	9	15 Two Stage Gas Valve Front	29
7 Typical Field Control Wiring Diagram Single Stage Thermostat-Single Stage Gas Heat	11	16 Single Stage Gas Valve Rear	29
8 Typical Field Control Wiring Diagram Single Stage Thermostat-Two Stage Gas Heat	11	17 Two Stage Gas Valve Rear	29
9 Typical Field Control Wiring Diagram Two Stage Thermostat-Two Stage Gas Heat	12	18 Proper Flame Adjustment	29
		19 R-410A Quick Reference Guide	43

General

YORK® Affinity Model DNQ units are cooling/heating air conditioners designed for outdoor installation. Only gas piping, electric power and duct pipe connections are required at the point of installation.

The single or two stage gas-fired heaters have spark to pilot ignition. The tubular heat exchangers are aluminized steel.

The refrigerant system is fully charged with R-410A Refrigerant, and is tested and factory sealed.

Safety Considerations

This is a safety alert symbol ▲. When you see this symbol on labels or in manuals, be alert to the potential for personal injury.

Understand and pay particular attention the signal words **DANGER, WARNING** or **CAUTION**.

DANGER indicates an **imminently** hazardous situation, which, if not avoided, **will result in death or serious injury**.

WARNING indicates a **potentially** hazardous situation, which, if not avoided, **could result in death or serious injury**.

CAUTION indicates a potentially hazardous situation, which, if not avoided **may result in minor or moderate injury**. It is also used to alert against unsafe practices and hazards involving only property damage.

⚠ WARNING

Improper installation may create a condition where the operation of the product could cause personal injury or property damage. Improper installation, adjustment, alteration, service or maintenance can cause injury or property damage. Refer to this manual for assistance or for additional information, consult a qualified contractor, installer or service agency.

⚠ CAUTION

This product must be installed in strict compliance with the installation instructions and any applicable local, state and national codes including, but not limited to building, electrical, and mechanical codes.

⚠ WARNING

Before performing service or maintenance operations on unit, turn off main power switch to unit. Electrical shock could cause personal injury. Improper installation, adjustment, alteration, service or maintenance can cause injury or property damage. Refer to this manual. For assistance or additional information consult a qualified installer, service agency or the gas supplier.

⚠ CAUTION

This system uses R-410A Refrigerant which operates at higher pressures than R-22. No other refrigerant may be used in this system. Gage sets, hoses, refrigerant containers and recovery systems must be designed to handle R-410A. If you are unsure, consult the equipment manufacturer. Failure to use R-410A compatible servicing equipment may result in property damage or injury.

⚠ WARNING

If the information in this manual is not followed exactly, a fire or explosion may result causing property damage, personal injury or loss of life.

Do not store or use gasoline or other flammable vapors and liquids in the vicinity of this or any other appliance.

WHAT TO DO IF YOU SMELL GAS:

- Do not try to light any appliance.
- Do not touch any electrical switch; do not use any phone in your building.
- Immediately call your gas supplier from a neighbor's phone. Follow the gas supplier's instructions.
- If you cannot reach your gas supplier, call the fire department.

Installation and service must be performed by a qualified installer, service agency or the gas supplier.

Due to system pressure, moving parts, and electrical components, installation and servicing of air conditioning equipment can be hazardous. Only qualified, trained service personnel should install, repair, or service this equipment. Untrained personnel can perform basic maintenance functions of cleaning coils and filters and replacing filters.

Observe all precautions in the literature, labels, and tags accompanying the equipment whenever working on air conditioning equipment. Be sure to follow all other applicable safety precautions and codes including ANSI Z223.1 or CSA-B149.1- latest edition.

Wear safety glasses and work gloves. Use quenching cloth and have a fire extinguisher available during brazing operations.

Inspection

As soon as a unit is received, it should be inspected for possible damage during transit. If damage is evident, the extent of the damage should be noted on the carrier's freight bill. A separate request for inspection by the carrier's agent should be made in writing.

⚠ CAUTION

This product must be installed in strict compliance with the enclosed installation instructions and any applicable local, state and national codes including, but not limited to, building, electrical, and mechanical codes.

The furnace and its individual shut-off valve must be disconnected from the gas supply piping system during any pressure testing at pressures in excess of 1/2 PSIG.

Pressures greater than 1/2 PSIG will cause gas valve damage resulting in a hazardous condition. If it is subjected to a pressure greater than 1/2 PSIG, the gas valve must be replaced.

The furnace must be isolated from the gas supply piping system by closing its individual manual shut-off valve during any pressure testing of the gas supply piping system at test pressures equal to or less than 1/2 PSIG

Reference

Additional information is available in the following reference forms:

- Technical Guide - DNQ024-060, 333491
- General Installation - DNQ024-060, 437758

Renewal Parts

Contact your local York® parts distribution center for authorized replacement parts.

Approvals

Design certified by CSA as follows:

1. For use as a cooling only unit, cooling unit with supplemental electric heat or a forced air furnace.
2. For outdoor installation only.

3. For installation on combustibile material and may be installed directly on combustibile flooring or, in the U.S., on wood flooring or Class A, Class B or Class C roof covering materials.
4. For use with natural gas (convertible to LP with kit).

CAUTION

This product must be installed in strict compliance with the enclosed installation instructions and any applicable local, state, and national codes including, but not limited to, building, electrical, and mechanical codes.

WARNING

Improper installation may create a condition where the operation of the product could cause personal injury or property damage.

CAUTION

This system uses R-410A Refrigerant which operates at higher pressures than R-22. No other refrigerant may be used in this system.

Nomenclature

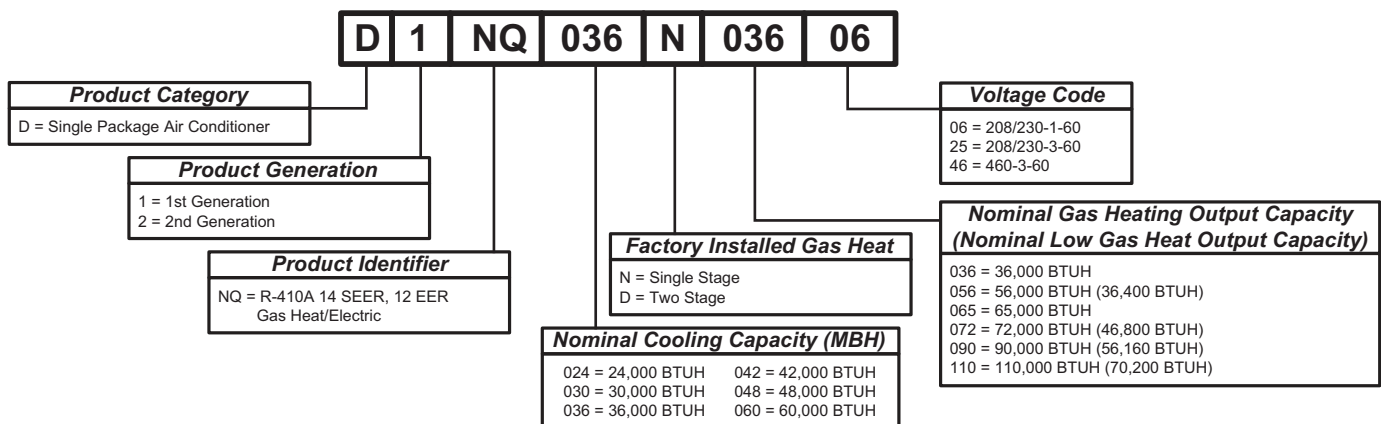

Installation

Installation Safety Information

Read these instructions before continuing this appliance installation. This is an outdoor combination heating and cooling unit. The installer must assure that these instructions are made available to the consumer and with instructions to retain them for future reference.

1. Refer to the unit rating plate for the approved type of gas for this product.
2. Install this unit only in a location and position as specified on Page 5 of these instructions.
3. Never test for gas leaks with an open flame. Use commercially available soap solution made specifically for the detection of leaks when checking all connections, as specified on Pages 3 and 16 of these instructions.
4. Always install furnace to operate within the furnace's intended temperature-rise range with the duct system and within the allowable external static pressure range, as specified on the unit name/rating plate, specified on Page 17 of these instructions.
5. This equipment is not to be used for temporary heating of buildings or structures under construction.

WARNING

FIRE OR EXPLOSION HAZARD

Failure to follow the safety warning exactly could result in serious injury, death or property damage.

Never test for gas leaks with an open flame. use a commercially available soap solution made specifically for the detection of leaks to check all connections. A fire or explosion may result causing property damage, personal injury or loss of life.

Limitations

These units must be installed in accordance with the following:

In U.S.A.:

1. National Electrical Code, ANSI/NFPA No. 70 - Latest Edition
2. National Fuel Gas Code, ANSI Z223.1 - Latest Edition
3. Gas-Fired Central Furnace Standard, ANSI Z21.47a. - Latest Edition
4. Local building codes, and
5. Local gas utility requirements

In Canada:

1. Canadian Electrical Code, CSA C22.1
2. Installation Codes, CSA - B149.1.
3. Local plumbing and waste water codes, and
4. Other applicable local codes.

Refer to unit application data found in this document.

After installation, gas fired units must be adjusted to obtain a temperature rise within the range specified on the unit rating plate.

If components are to be added to a unit to meet local codes, they are to be installed at the dealer's and/or customer's expense.

Size of unit for proposed installation should be based on heat loss/heat gain calculation made according to the methods of Air Conditioning Contractors of America (ACCA).

This furnace is not to be used for temporary heating of buildings or structures under construction.

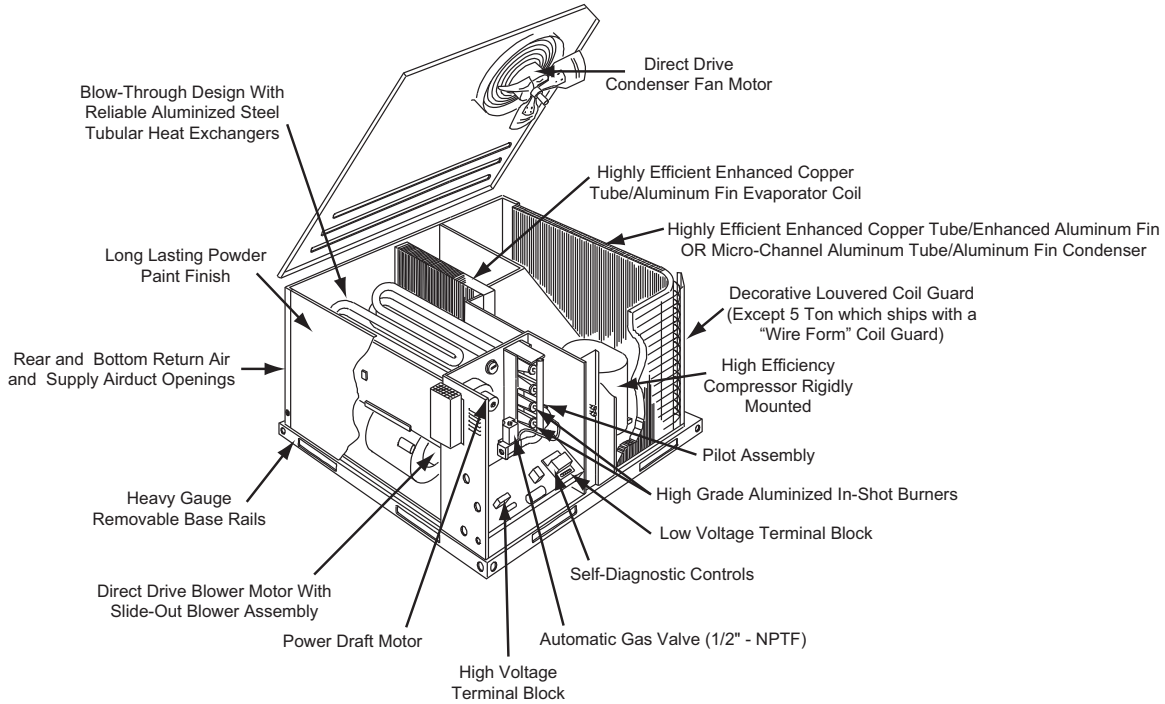

Figure 1: Component Location

Table 1: Unit Limitations

Size (Tons)	Unit Voltage	Unit Limitations		
		Applied Voltage		Outdoor DB Temp
		Min	Max	Max (°F)
024 (2.0)	208/230-1-60	187	252	125
030 (2.5)	208/230-1-60	187	252	115
	208/230-3-60	187	252	115
	460-3-60	432	504	115
036 (3.0)	208/230-1-60	187	252	115
	208/230-3-60	187	252	115
	460-3-60	432	504	115
042 (3.5)	208/230-1-60	187	252	125
	208/230-3-60	187	252	125
	460-3-60	432	504	125
048 (4.0)	208/230-1-60	187	252	115
	208/230-3-60	187	252	115
	460-3-60	432	504	115
060 (5.0)	208/230-1-60	187	252	125
	208/230-3-60	187	252	125
	460-3-60	432	504	125

Location

Use the following guidelines to select a suitable location for these units:

1. Unit is designed for *outdoor installation only*.
2. Condenser coils must have an unlimited supply of air. Where a choice of location is possible, position the unit on either north or east side of building.
3. Suitable for mounting on roof curb.
4. For ground level installation, a level pad or slab should be used. The thickness and size of the pad or slab used should meet local codes and unit weight. Do not tie the slab to the building foundation.
5. Roof structures must be able to support the weight of the unit and its options/accessories. Unit must be installed on a solid, level roof curb or appropriate angle iron frame.
6. Maintain level tolerance to 1/8" across the entire width and length of unit.

⚠ WARNING

Excessive exposure of this furnace to contaminated combustion air may result in equipment damage or personal injury. Typical contaminants include: permanent wave solution, chlorinated waxes and cleaners, chlorine based swimming pool chemicals, water softening chemicals, carbon tetrachloride, Halogen type refrigerants, cleaning solvents (e.g. perchloroethylene), printing inks, paint removers, varnishes, hydrochloric acid, cements and glues, antistatic fabric softeners for clothes dryers, masonry acid washing materials.

Clearances

All units require particular clearances for proper operation and service. Installer must make provisions for adequate combustion and ventilation air in accordance with section 5.3 of Air for Combustion and Ventilation of the National Fuel Gas Code, ANSI Z223.1 – Latest Edition (in U.S.A.), or Sections 7.2, 7.3, or 7.4 of Gas Installation Codes, CSA-B149.1 (in Canada) - Latest Edition, and/or applicable provisions of the local building

codes. Refer to Table 5 for clearances required for combustible construction, servicing, and proper unit operation.

⚠ WARNING

Do not permit overhanging structures or shrubs to obstruct condenser air discharge outlet, combustion air inlet or vent outlets.

Rigging And Handling

Exercise care when moving the unit. Do not remove any packaging until the unit is near the place of installation. Rig the unit by attaching chain or cable slings to the lifting holes provided in the base rails. Spreader bars, whose length exceeds the largest dimension across the unit, **MUST** be used across the top of the unit.

⚠ CAUTION

If a unit is to be installed on a roof curb other than a York® roof curb, gasketing must be applied to all surfaces that come in contact with the unit underside.

⚠ CAUTION

Before lifting, make sure the unit weight is distributed equally on the rigging cables so it will lift evenly.

Units may be moved or lifted with a forklift. Slotted openings in the base rails are provided for this purpose.

⚠ CAUTION

All panels must be secured in place when the unit is lifted.
The condenser coils should be protected from rigging cable damage with plywood or other suitable material.

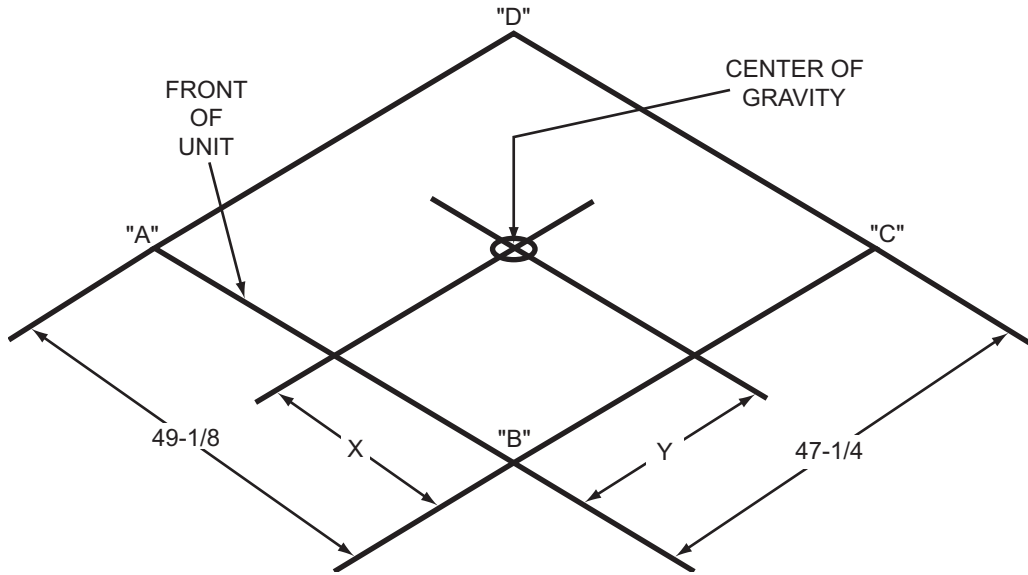

Figure 2: Unit 4 Point Load Weight

Table 2: Weights and Dimensions

Size (Tons)	Weight (lbs.)		Center of Gravity		4 Point Load Location (lbs.)			
	Shipping	Operating	X	Y	A	B	C	D
024 (2.0)	395	390	20	24.5	113	81	82	114
030 (2.5)	430	425	20	24.25	122	88	90	125
036 (3.0)	435	430	20	24.25	123	89	91	127
042 (3.5)	490	485	20	24	138	99	104	144
048 (4.0)	495	490	20	24	139	100	105	146
060 (5.0)	535	530	20	24	150	108	114	158

Table 3: Unit Accessory Weights

Unit Accessory	Model	Weight (lbs.)	
		Shipping	Operating
Add Economizer	All	45	40

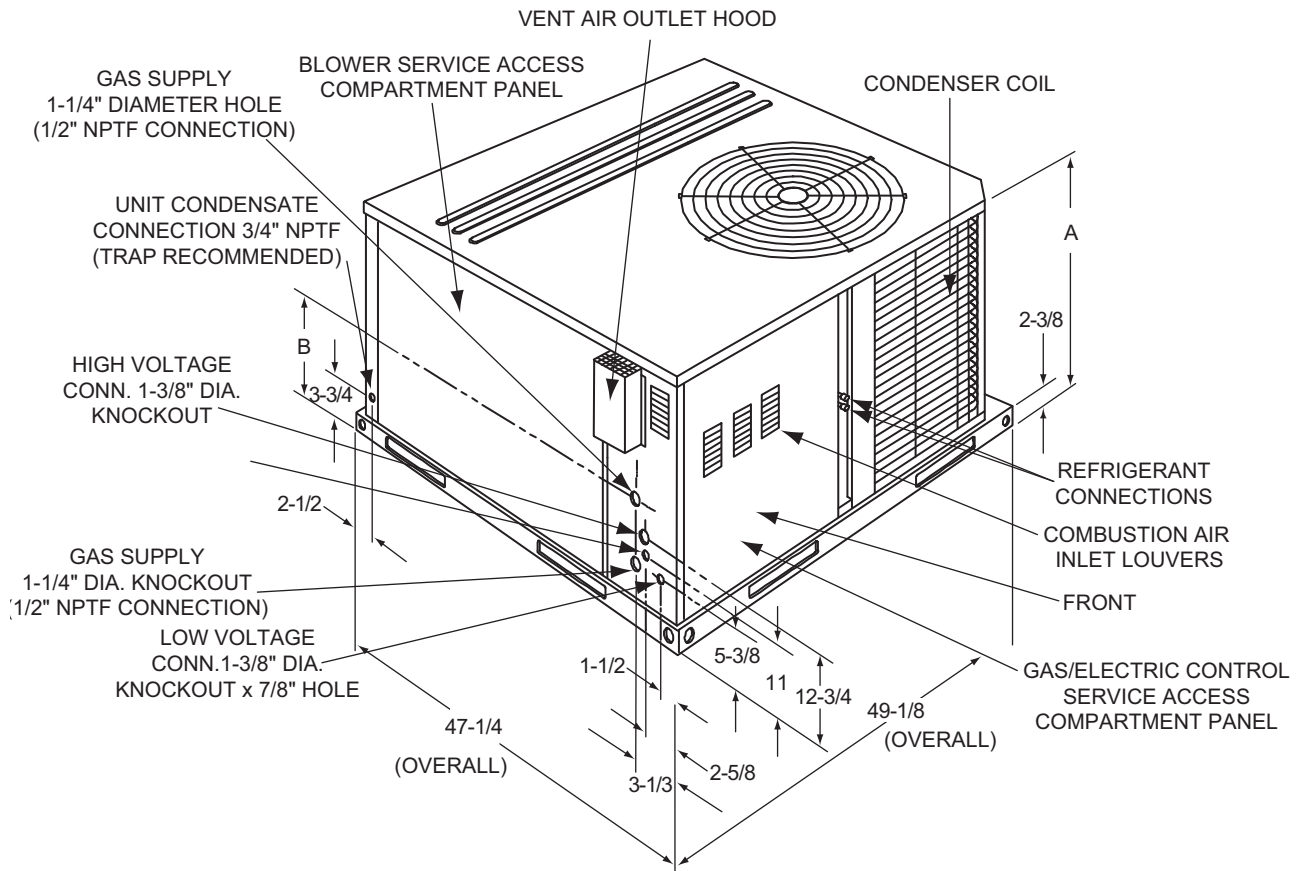

Figure 3: Unit Dimensions

Table 4: Unit Dimensions Front

Unit Size	Dimensions	
	"A"	"B"
024, 030, 036	33-1/2	18-1/4
042, 048, 060	41-1/2	23-1/8

Table 5: Unit Clearances^{1 2}

Direction	Distance (in.)	Direction	Distance (in.)
Top ³	36	Right	12
Front	36	Left	24
Rear	0	Bottom ⁴	0

1. A 1" clearance must be provided between any combustible material and the supply air duct work.
2. The products of combustion must not be allowed to accumulate within a confined space and recirculate.
3. Units must be installed outdoors. Over hanging structure or shrubs should not obscure condenser air discharge outlet.
4. Units may be installed on combustible floors made from wood or class A, B or C roof covering materials.

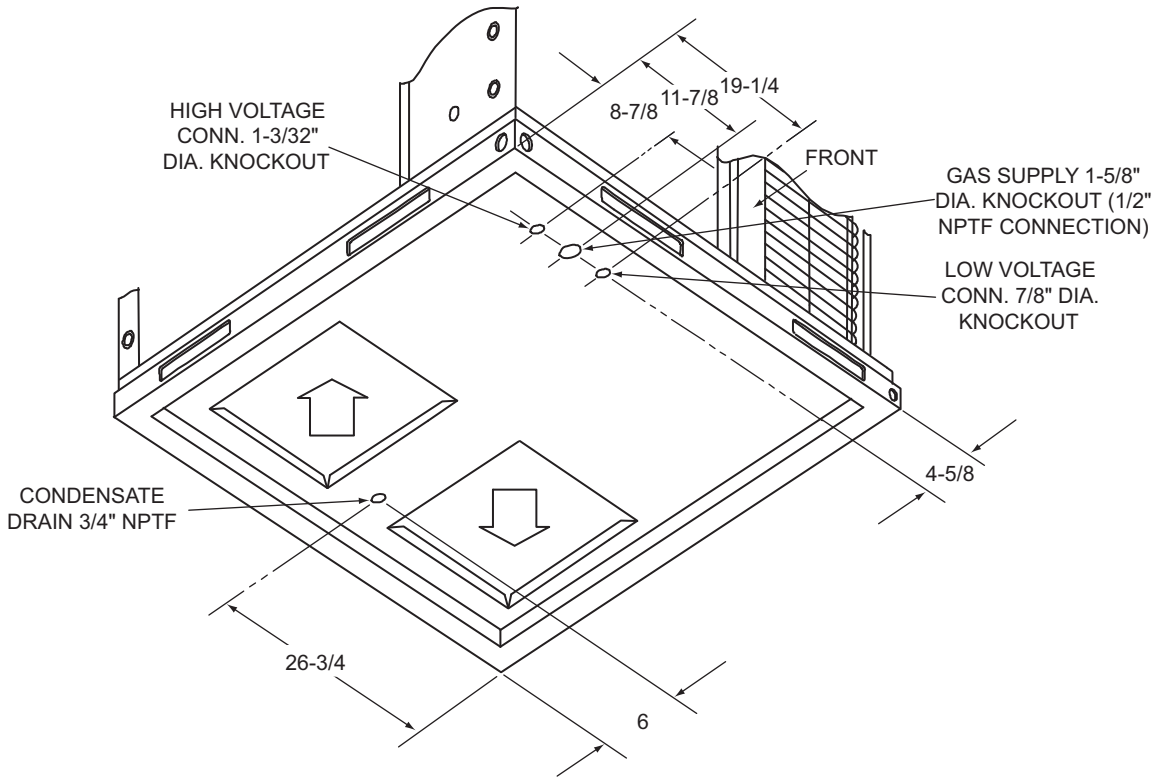

Figure 4: Dimensions Front and Bottom

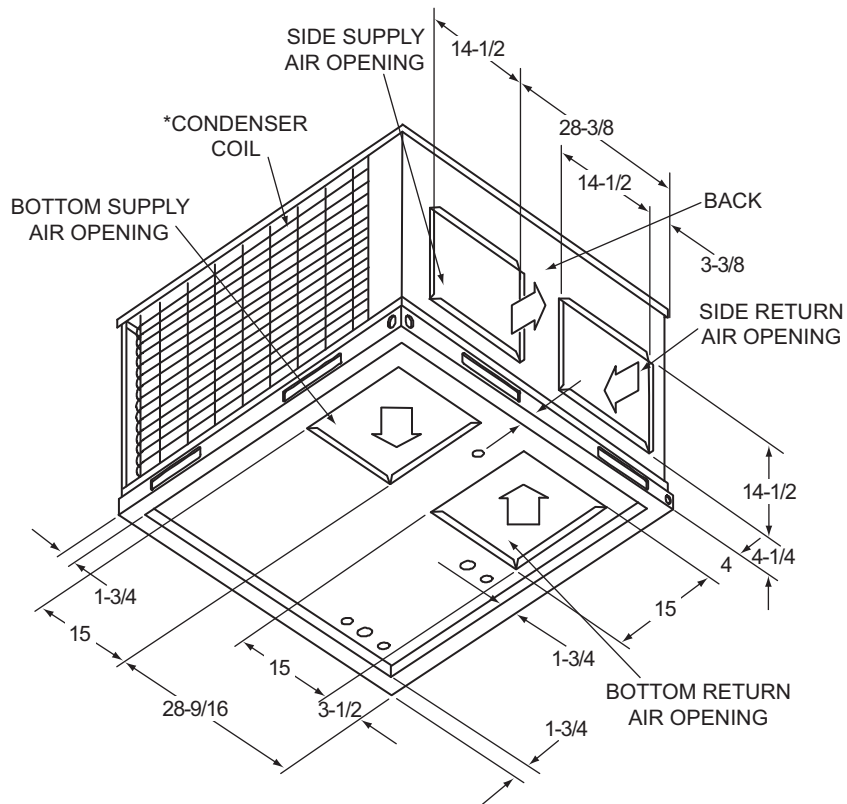

Figure 5: Dimensions Back and Bottom

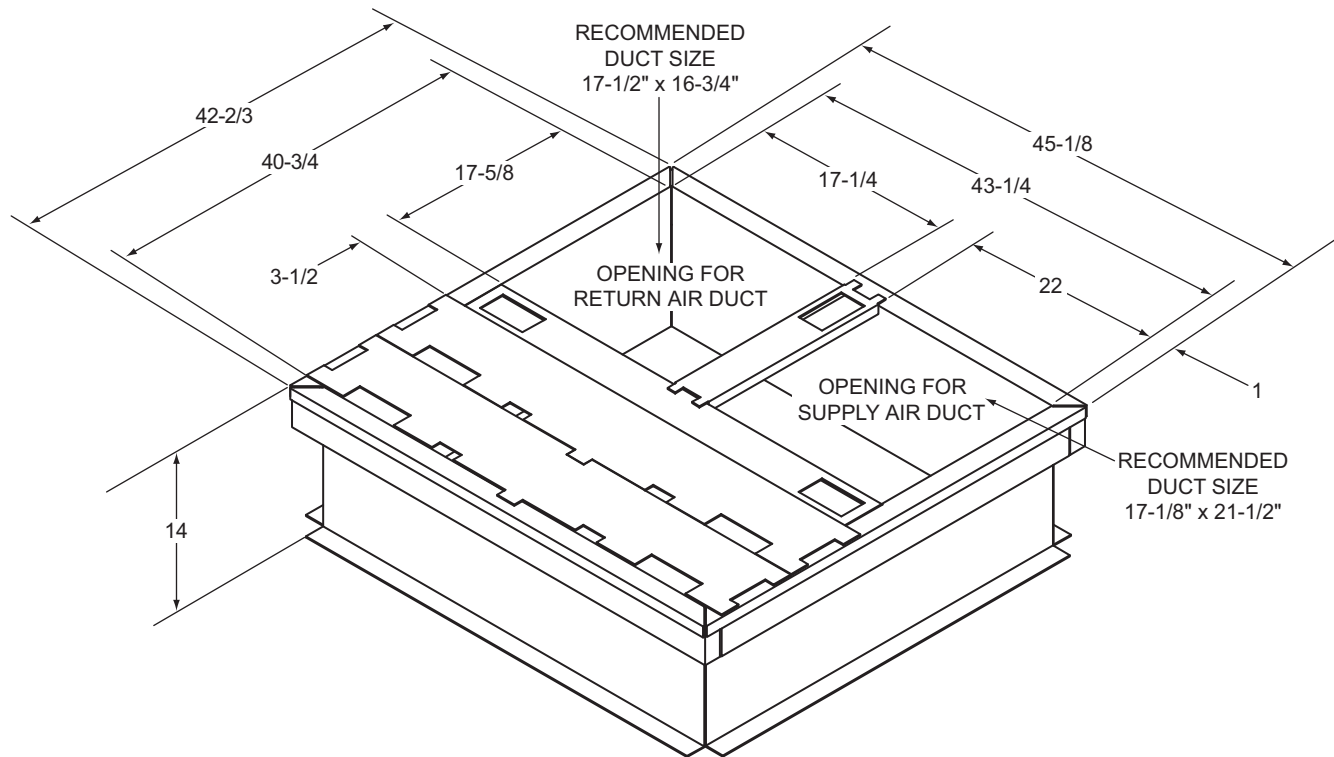

Figure 6: Roof Curb¹

Ductwork

These units are adaptable to downflow use as well as rear supply and return air duct openings. To convert to downflow, use the following steps:

1. Remove the duct covers found in the bottom return and supply air duct openings. There are four (4) screws securing each duct cover (save these screws to use in Step 2).
2. Install the duct covers (removed in step one) to the rear supply and return air duct openings. Secure with the four (4) screws used in step one.
3. Seal duct covers with silicone caulk.

Duct work should be designed and sized according to the methods of the Air Conditioning Contractors of America (ACCA), as set forth in their Manual D.

A closed return duct system shall be used. This shall not preclude use of economizers or ventilation air intake. Flexible joints may be used in the supply and return duct work to minimize the transmission of noise.

NOTE: Be sure to note supply and return openings.

Refer to Figures 4 and 5 for information concerning rear and bottom supply and return air duct openings.

Roof Curb

On applications when a roof curb is used, the unit must be positioned on the curb so the front of the unit is tight against the curb.

Filters

Single phase units are shipped without a filter or filter racks. It is the responsibility of the installer to secure a filter in the return air ductwork or install a Filter/Frame Kit (1FF0110, 1FF0112 or 1FF0114).

A filter rack and high velocity filters are standard on three phase units.

Filters must always be used and must be kept clean. When filters become dirt laden, insufficient air will be delivered by the blower, decreasing your units efficiency and increasing operating costs and wear-and-tear on the unit and controls.

Filters should be checked monthly; this is especially important since this unit is used for both heating and cooling.

¹. 8" Roof Curb also available.

Condensate Drain

A condensate trap is recommended to be installed in the condensate drain. The plumbing must conform to local codes.

Use a sealing compound on male pipe threads. Install the condensate drain line (3/4" NPTF) to spill into an open drain.

CAUTION

Hand tighten only.

Service Access

Access to all serviceable components is provided at the following locations:

- Blower compartment access panel
- Gas control/electrical access panel
- Refrigerant connections

Refer to Figure 3 for location of these access locations and minimum clearances in Table 5.

CAUTION

This system uses R-410A Refrigerant which operates at higher pressures than R-22. No other refrigerant may be used in this system. Gage sets, hoses, refrigerant containers and recovery systems must be designed to handle R-410A. If you are unsure, consult the equipment manufacturer. Failure to use R-410A compatible servicing equipment may result in property damage or injury.

WARNING

Wear safety glasses and gloves when handling refrigerants. Failure to follow this warning can cause serious personal injury.

Refer to Figure 19 for the R-410A Quick Reference Guide.

Thermostat

The room thermostat should be located on an inside wall approximately 56" above the floor where it will not be subject to drafts, sun exposure or heat from electrical fixtures or appliances. Follow manufacturer's instructions enclosed with the thermostat for general installation procedure. Color coded insulated wires (minimum #18 AWG) should be used to connect thermostat to unit. See Figures 7 thru 10.

Power And Control Wiring

Field wiring to the unit must conform to provisions of the current N.E.C. ANSI/NFPA No. 70 or C.E.C. and/or local ordinances. The unit must be electrically grounded in accordance with local codes or, in their absence, with the N.E.C./C.E.C. Voltage tolerances which must be maintained at the compressor terminals during starting and running conditions are indicated on the unit Rating Plate and Table 6.

The wiring entering the cabinet must be provided with mechanical strain relief.

A fused disconnect switch should be field provided for the unit. If any of the wire supplied with the unit must be replaced, replacement wire must be of the type shown on the wiring diagram.

Electrical line must be sized properly to carry the load. Each unit must be wired with a separate branch circuit fed directly from the meter panel and properly fused.

Refer to Figures 7 thru 10 for typical field wiring and to the appropriate unit wiring diagram for control circuit and power wiring information.

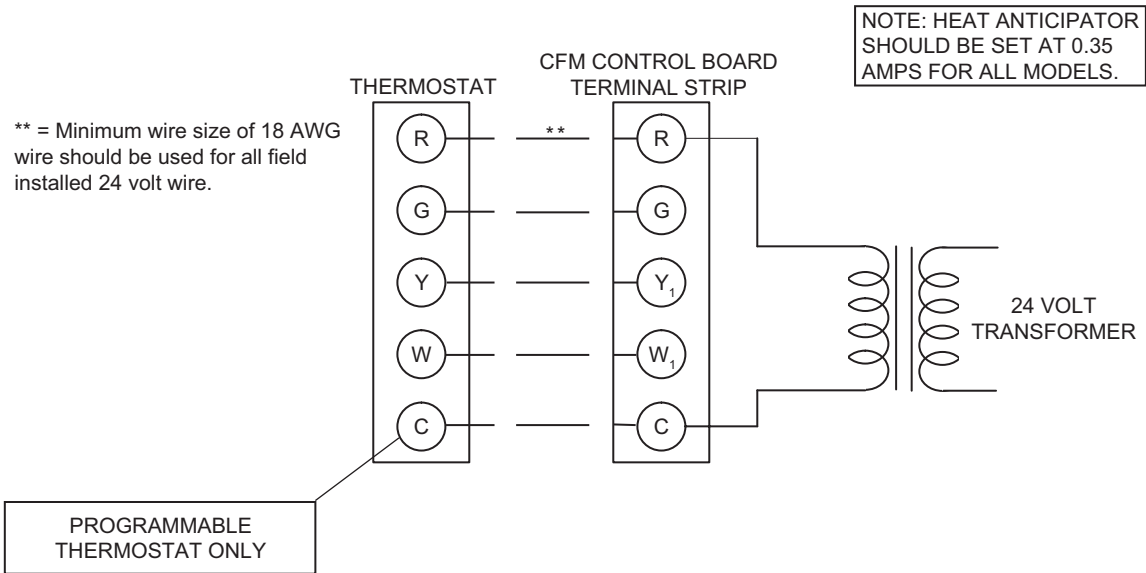

Figure 7: Typical Field Control Wiring Diagram Single Stage Thermostat-Single Stage Gas Heat

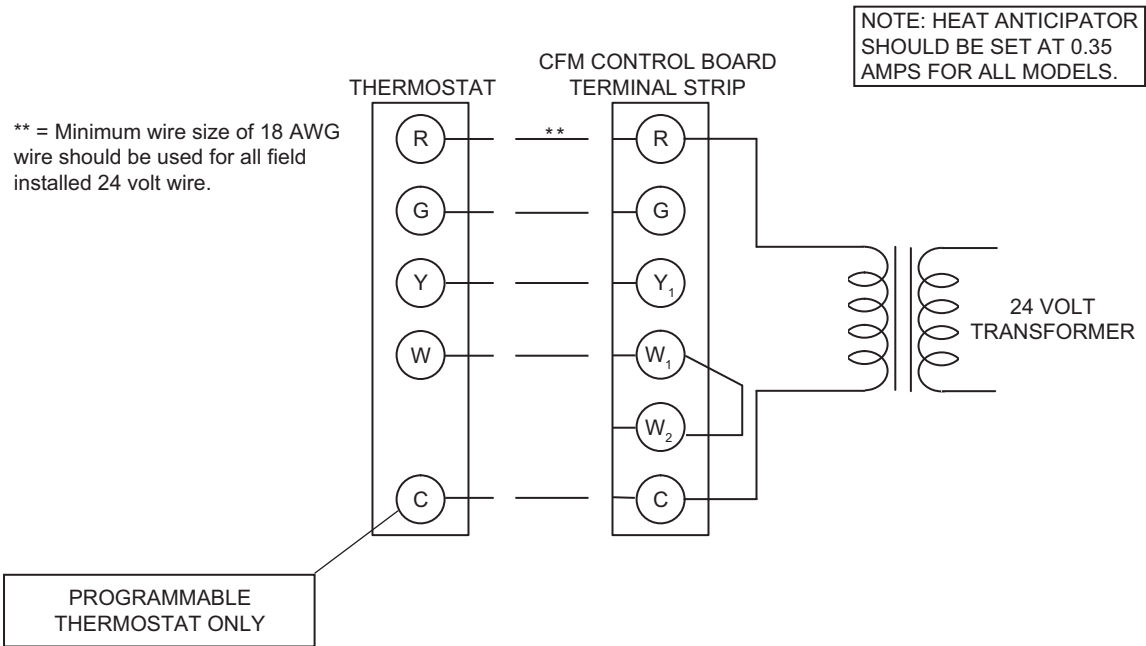

Figure 8: Typical Field Control Wiring Diagram Single Stage Thermostat-Two Stage Gas Heat

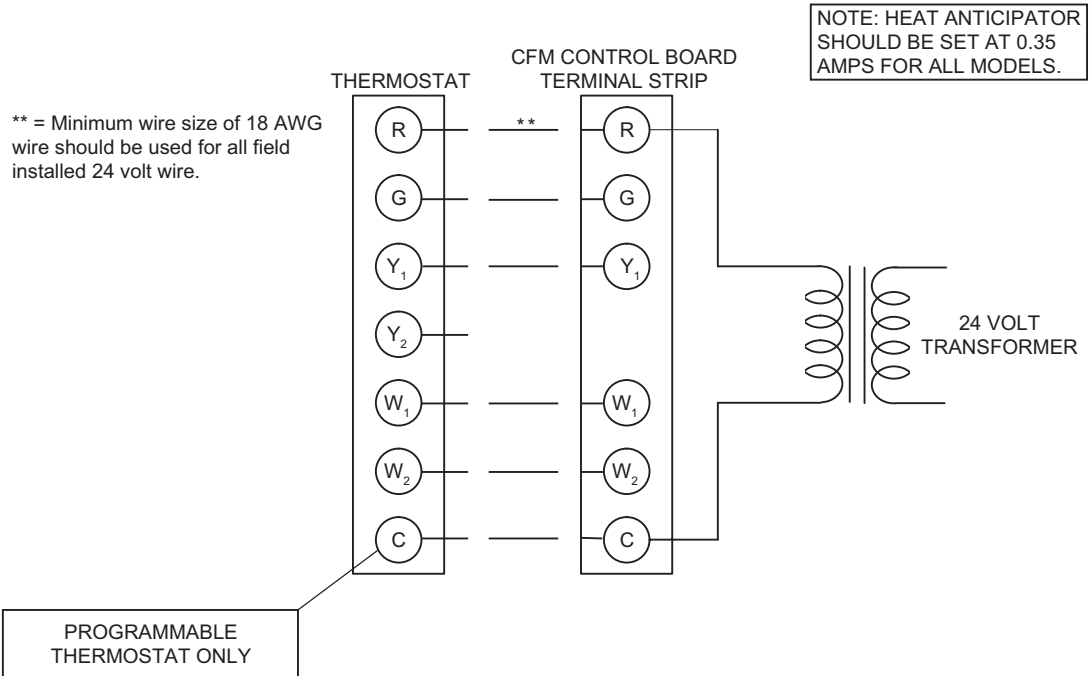

Figure 9: Typical Field Control Wiring Diagram Two Stage Thermostat-Two Stage Gas Heat

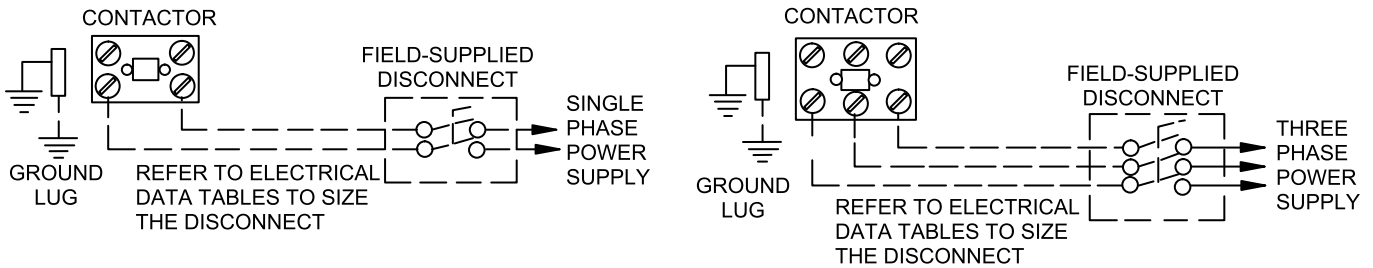

Figure 10: Typical Field Power Wiring Diagram

Table 6: Electrical Data

Size (Tons)	Volt	Compressors (each)			OD Fan Motors (each)	Supply Blower Motor	MCA ¹ (Amps)	Max Fuse ² / Breaker ³ Size (Amps)
		RLA	LRA	MCC	FLA	FLA		
024 (2.0)	208/230-1-60	8.3	43	13	1.4	4.3	16.1	20
	208/230-3-60	14.1	73	22	1.4	6.8	25.8	35
030 (2.5)	208/230-3-60	8.9	58	14	1.4	6.8	19.3	25
	460-3-60	4.2	28	7	0.8	3.4	9.5	15
036 (3.0)	208/230-1-60	14.1	77	22	1.4	6.8	25.8	35
	208/230-3-60	9.0	71	14	1.4	6.8	19.5	25
	460-3-60	5.6	38	9	0.8	3.4	11.2	15
042 (3.5)	208/230-1-60	21.8	105	34	1.7	9.1	38.1	50
	208/230-3-60	14.1	95	22	1.7	9.1	28.4	35
	460-3-60	6.4	45	10	0.9	4.6	13.5	15
048 (4.0)	208/230-1-60	20.5	115	32	1.7	9.1	36.4	45
	208/230-3-60	16.0	120	25	1.7	9.1	30.8	40
	460-3-60	7.7	50	12	0.9	4.6	15.1	20
060 (5.0)	208/230-1-60	25.0	134	39	2.8	9.1	43.2	60
	208/230-3-60	15.9	110	25	2.8	9.1	31.8	40
	460-3-60	7.7	52	12	1.4	4.6	15.6	20

1. Minimum Circuit Ampacity.
2. Maximum Over Current Protection per standard UL 1995.
3. Fuse or HACR circuit breaker size installed at factory or field installed.

Table 7: Single Stage Physical Data

Component	Models															
	DNQ024		DNQ030		DNQ036		DNQ042		DNQ048		DNQ060					
Nominal Tonnage	2.0	2.5	3.0	3.5	4.0	5.0										
ARI COOLING PERFORMANCE																
Gross Capacity @ ARI A point (Btu)	24.0	29.8	35.7	43.5	49.6	56.8*										
ARI net capacity (Btu)	23.5	29.0	34.5	42.0	48.0	55.0*										
EER	12.0	12.0	12.0	12.0	12.0	12.0*										
SEER	14.0	14.0	14.0	14.0	14.0	14.0*										
Nominal CFM	800	900	1100	1400	1500	1550										
System power (KW)	2.0	2.4	2.9	3.5	4.0	4.6										
Refrigerant type	R-410A	R-410A	R-410A	R-410A	R-410A	R-410A										
Refrigerant charge (lb-oz)	3-8	3-2	3-10	4-8	4-6	5-15										
ARI HEATING PERFORMANCE																
Heating model	N036	N056	N036	N056	N036	N056	N072	N065	N090	N065	N090	N110	N065	N090	N110	
Heat input (K Btu)	45	70	45	70	45	70	90	80	108	80	108	135	80	108	135	
Heat output (K Btu)	36	56	36	56	36	56	72	64	87	64	87	108	64	87	108	
AFUE %	80.0	80.0	80.0	80.0	80.0	80.0	80.0	80.0	80.0	80.0	80.0	80.0	80.0	80.0	80.0	
Steady state efficiency (%)	80	80	80	80	80	80	80	80	80	80	80	80	80	80	80	
No. burners	2	3	2	3	2	3	4	3	4	3	4	5	3	4	5	
No. stages	1	1	1	1	1	1	1	1	1	1	1	1	1	1	1	
Temperature Rise Range (°F)	25-55	30-60	25-55	30-60	25-55	25-55	30-60	25-55	45-75	25-55	35-65	45-75	25-55	35-65	45-75	
Gas Limit Setting (°F)	140	160	140	160	140	160	160	140	160	150	175	160	150	175	160	
Gas piping connection (in.)	1/2		1/2		1/2		1/2		1/2		1/2		1/2		1/2	
DIMENSIONS (inches)																
Length	49 1/8		49 1/8		49 1/8		49 1/8		49 1/8		49 1/8		49 1/8		49 1/8	
Width	47 1/4		47 1/4		47 1/4		47 1/4		47 1/4		47 1/4		47 1/4		47 1/4	
Height	33 1/2		33 1/2		33 1/2		33 1/2		41 1/2		41 1/2		41 1/2		41 1/2	
OPERATING WT. (lbs.)																
	390		425		430		485		490		530		530		530	
COMPRESSORS																
Type	Recip 1-spd		Scroll 1-spd		Scroll 1-spd		Scroll 1-spd		Scroll 1-spd		Scroll 1-spd		Scroll 1-spd		Scroll 1-spd	
Quantity	1		1		1		1		1		1		1		1	
CONDENSER COIL DATA																
Face area (Sq. Ft.)	7.9		11.9		11.9		15		15		15		15		15	
Rows	1		1		1		1		1		1		1		1	
Fins per inch	23		23		23		23		23		23		23		23	
Tube diameter (in.)	0.71 / 18		0.71 / 18		0.71 / 18		0.71 / 18		0.71 / 18		0.71 / 18		0.98 / 25		0.98 / 25	
Circuitry Type	2-pass Micro-Channel															
EVAPORATOR COIL DATA																
Face area (Sq. Ft.)	3.4		3.4		3.4		4.4		4.4		4.4		4.4		4.4	
Rows	2		3		3		3		3		3		4		4	
Fins per inch	15		13		13		16		16		16		13		13	
Tube diameter	3/8		3/8		3/8		3/8		3/8		3/8		3/8		3/8	
Circuitry Type	Interlaced		Interlaced		Interlaced		Interlaced		Interlaced		Interlaced		Interlaced		Interlaced	
Refrigerant control	TXV		TXV		TXV		TXV		TXV		TXV		TXV		TXV	
CONDENSER FAN DATA																
Quantity	1		1		1		1		1		1		1		1	
Fan diameter (Inch)	22		22		22		22		22		22		22		22	
Type	Prop		Prop		Prop		Prop		Prop		Prop		Prop		Prop	
Drive type	Direct		Direct		Direct		Direct		Direct		Direct		Direct		Direct	
No. speeds	1		1		1		1		1		1		1		1	
Number of motors	1		1		1		1		1		1		1		1	
Motor HP each	1/4		1/4		1/4		1/3		1/3		1/3		1/3		1/3	
RPM	1100		1100		1100		1100		1100		1100		1100		1100	
Nominal total CFM	2400		2400		2400		3200		3200		3200		3200		3200	
DIRECT DRIVE EVAP FAN DATA																
Quantity	1		1		1		1		1		1		1		1	
Fan Size (Inch)	10 x 8		10 x 8		11 x 10		12 x 11		12 x 11		12 x 11		12 x 11		12 x 11	
Type	Centrifugal		Centrifugal		Centrifugal		Centrifugal		Centrifugal		Centrifugal		Centrifugal		Centrifugal	
Motor HP each	1/2		3/4		3/4		3/4		3/4		1		1		1	
RPM	Variable		Variable		Variable		Variable		Variable		Variable		Variable		Variable	
Frame size	48		48		48		48		48		48		48		48	
FILTERS																
Quantity - Size	1 - 20 x 20 x 1		1 - 20 x 20 x 1		1 - 20 x 20 x 1		2 - 20 x 12 x 1		2 - 20 x 12 x 1		2 - 20 x 12 x 1		2 - 20 x 12 x 1		2 - 20 x 12 x 1	

* Rating established with a "Wire Form" coil guard which ships as standard.

Table 8: Two Stage Physical Data

Component	Models									
	DNQ024	DNQ030	DNQ036	DNQ042	DNQ048	DNQ060				
Nominal Tonnage	2.0	2.5	3.0	3.5	4.0	5.0				
ARI COOLING PERFORMANCE										
Gross Capacity @ ARI A point (Btu)	24.0	29.8	35.7	43.5	49.6	56.8*				
ARI net capacity (Btu)	23.5	29.0	34.5	42.0	48.0	55.0*				
EER	12.0	12.0	12.0	12.0	12.0	12.0*				
SEER	14.0	14.0	14.0	14.0	14.0	14.0*				
Nominal CFM	800	900	1100	1400	1500	1550				
System power (KW)	2.0	2.4	2.9	3.5	4.0	4.6				
Refrigerant type	R-410A	R-410A	R-410A	R-410A	R-410A	R-410A				
Refrigerant charge (lb-oz)	3-8	3-2	3-10	4-8	4-6	5-15				
ARI HEATING PERFORMANCE										
Heating model	D056	D056	D056	D072	D090	D090	D110	D090	D110	
Heat input (K Btu)	70/45.5	70/45.5	70/45.5	90/58.5	108/70.2	108/70.2	135/87.8	108/70.2	135/87.8	
Heat output (K Btu)	56/36.4	56/36.4	56/36.4	72/46.8	87/56.2	87/56.2	108/70.2	87/56.2	108/70.2	
AFUE %	80.0	80.0	80.0	80.0	80.0	80.0	80.0	80.0	80.0	
Steady state efficiency (%)	80	80	80	80	80	80	80	80	80	
No. burners	3	3	3	4	4	4	5	4	5	
No. stages	2	2	2	2	2	2	2	2	2	
Temperature Rise Range (°F)	30-60	30-60	25-55	30-60	45-75	35-65	45-75	35-65	45-75	
Gas Limit Setting (°F)	160	160	160	160	175	175	170	175	170	
Gas piping connection (in.)	1/2	1/2	1/2	1/2	1/2	1/2	1/2	1/2	1/2	
DIMENSIONS (inches)										
Length	49 1/8	49 1/8	49 1/8	49 1/8	49 1/8	49 1/8	49 1/8	49 1/8	49 1/8	
Width	47 1/4	47 1/4	47 1/4	47 1/4	47 1/4	47 1/4	47 1/4	47 1/4	47 1/4	
Height	33 1/2	33 1/2	33 1/2	33 1/2	41 1/2	41 1/2	41 1/2	41 1/2	41 1/2	
OPERATING WT. (lbs.)										
	390	425	430	485	490	530				
COMPRESSORS										
Type	Recip 1-spd	Scroll 1-spd	Scroll 1-spd	Scroll 1-spd	Scroll 1-spd	Scroll 1-spd	Scroll 1-spd	Scroll 1-spd	Scroll 1-spd	
Quantity	1	1	1	1	1	1	1	1	1	
CONDENSER COIL DATA										
Face area (Sq. Ft.)	7.9	11.9	11.9	15	15	15	15	15	15	
Rows	1	1	1	1	1	1	1	1	1	
Fins per inch	23	23	23	23	23	23	23	23	23	
Tube diameter (in.)	0.71 / 18	0.71 / 18	0.71 / 18	0.71 / 18	0.71 / 18	0.71 / 18	0.71 / 18	0.98 / 25	0.98 / 25	
Circuitry Type	2-pass Micro-Channel									
EVAPORATOR COIL DATA										
Face area (Sq. Ft.)	3.4	3.4	3.4	4.4	4.4	4.4	4.4	4.4	4.4	
Rows	2	3	3	3	3	3	3	4	4	
Fins per inch	15	13	13	16	16	16	16	13	13	
Tube diameter	3/8	3/8	3/8	3/8	3/8	3/8	3/8	3/8	3/8	
Circuitry Type	Interlaced	Interlaced	Interlaced	Interlaced	Interlaced	Interlaced	Interlaced	Interlaced	Interlaced	
Refrigerant control	TXV	TXV	TXV	TXV	TXV	TXV	TXV	TXV	TXV	
CONDENSER FAN DATA										
Quantity	1	1	1	1	1	1	1	1	1	
Fan diameter (Inch)	22	22	22	22	22	22	22	22	22	
Type	Prop	Prop	Prop	Prop	Prop	Prop	Prop	Prop	Prop	
Drive type	Direct	Direct	Direct	Direct	Direct	Direct	Direct	Direct	Direct	
No. speeds	1	1	1	1	1	1	1	1	1	
Number of motors	1	1	1	1	1	1	1	1	1	
Motor HP each	1/4	1/4	1/4	1/3	1/3	1/3	1/3	1/3	1/3	
RPM	1100	1100	1100	1100	1100	1100	1100	1100	1100	
Nominal total CFM	2400	2400	2400	3200	3200	3200	3200	3200	3200	
DIRECT DRIVE EVAP FAN DATA										
Quantity	1	1	1	1	1	1	1	1	1	
Fan Size (Inch)	10 x 8	10 x 8	11 x 10	12 x 11	12 x 11	12 x 11	12 x 11	12 x 11	12 x 11	
Type	Centrifugal	Centrifugal	Centrifugal	Centrifugal	Centrifugal	Centrifugal	Centrifugal	Centrifugal	Centrifugal	
Motor HP each	1/2	3/4	3/4	3/4	3/4	1	1	1	1	
RPM	Variable	Variable	Variable	Variable	Variable	Variable	Variable	Variable	Variable	
Frame size	48	48	48	48	48	48	48	48	48	
FILTERS										
Quantity - Size	1 - 20 x 20 x 1	1 - 20 x 20 x 1	1 - 20 x 20 x 1	2 - 20 x 12 x 1	2 - 20 x 12 x 1	2 - 20 x 12 x 1	2 - 20 x 12 x 1	2 - 20 x 12 x 1	2 - 20 x 12 x 1	

* Rating established with a "Wire Form" coil guard which ships as standard.

Compressors

The scroll compressor used in this product is specifically designed to operate with R-410A Refrigerant and cannot be interchanged.

CAUTION

This system uses R-410A Refrigerant which operates at higher pressures than R-22. No other refrigerant may be used in this system.

The compressor also uses a polyolester (POE oil), Mobil 3MA POE. This oil is extremely hygroscopic, meaning it absorbs water readily. POE oil can absorb 15 times as much water as other oils designed for HCFC and CFC refrigerants. Take all necessary precautions to avoid exposure of the oil to the atmosphere.

CAUTION

Do not leave the system open to the atmosphere. Unit damage could occur due to moisture being absorbed by the **POE oil** in the system. This type of oil is highly susceptible to moisture absorption

POE (polyolester) compressor lubricants are known to cause long term damage to some synthetic roofing materials.

CAUTION

Exposure, even if immediately cleaned up, may cause embrittlement (leading to cracking) to occur in one year or more. When performing any service that may risk exposure of compressor oil to the roof, take precautions to protect roofing.

Procedures which risk oil leakage include, but are not limited to, compressor replacement, repairing refrigerant leaks, replacing refrigerant components such as filter drier, pressure switch, metering device or coil.

Units are shipped with compressor mountings which are factory-adjusted and ready for operation.

CAUTION

Do not loosen compressor mounting bolts.

Phasing

Three-phase, scroll compressors operate in only one direction. If the scroll is drawing low amperage, has similar suction and discharge pressures, or is producing a high noise level, the scroll is misphased. Change the incoming line connection phasing to obtain the proper rotation.

CAUTION

Scroll compressors require proper rotation to operate properly. Failure to check and correct rotation may result in property damage.

Gas Heat

These single or two stage gas-fired heaters have aluminized-steel tubular heat exchangers with spark to pilot ignition.

Gas Piping

Proper sizing of gas piping depends on the cubic feet per hour of gas flow required, specific gravity of the gas and the length of run. National Fuel Gas Code Z223.1 or CSA B149.1 should be followed in all cases unless superseded by local codes or gas company requirements. Refer to Tables 9 and 10.

The heating value of the gas may differ with locality. The value should be checked with the local gas utility.

NOTE: There may be a local gas utility requirement specifying a minimum diameter for gas piping. All units require a 1/2 inch pipe connection at the gas valve.

Gas Connection

The gas supply line can be routed through the hole located on the left side of the unit. Refer to Figure 3 to locate these access openings. Typical supply piping arrangements are shown in Figure 11.

Gas piping requirements:

1. A drip leg and a ground joint union must be installed in the gas piping.
2. When required by local codes, a manual shut-off valve may have to be installed outside of the unit.
3. Use wrought iron or steel pipe for all gas lines. Pipe dope should be applied sparingly to male threads only.

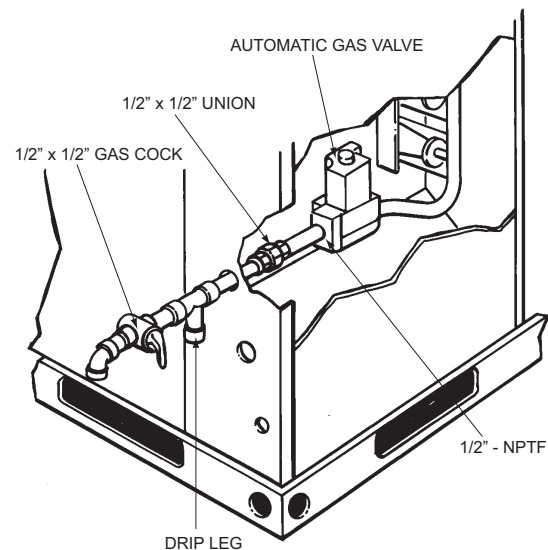

Figure 11: External Supply Connection External Shut-Off

Table 9: Natural Gas Pipe Sizing Chart¹

Length In Feet	Nominal Inches Iron Pipe Size			
	1/2"	3/4"	1"	1-1/4"
10	132	278	520	1,050
20	92	190	350	730
30	73	152	285	590
40	63	130	245	500
50	56	115	215	440
60	50	105	195	400
70	46	96	180	370
80	43	90	170	350
90	40	84	160	320
100	38	79	150	305

1. Maximum capacity of pipe in cubic feet of gas per hour (based upon a pressure drop of 0.3 inch water column and 0.6 specific gravity gas).

Table 10: Propane (LP) Gas Pipe Sizing Chart¹

Length In Feet	Nominal Inches Iron Pipe Size			
	1/2"	3/4"	1"	1-1/4"
10	275	567	1,071	2,205
20	189	393	732	1,496
30	152	315	590	1,212
40	129	267	504	1,039
50	114	237	448	913
60	103	217	409	834
70	96	196	378	771
80	89	185	346	724
90	83	173	322	677
100	78	162	307	630

1. Maximum capacity of pipe in thousands of BTU per hour (based upon a pressure drop of 0.5 inch water column).

CAUTION

If flexible stainless steel tubing is allowed by the authority having jurisdiction, wrought iron or steel pipe must be installed at the gas valve and extend a minimum of two (2) inches outside of the unit casing.

WARNING

Natural gas may contain some propane. Propane being an excellent solvent, will quickly dissolve white lead or most standard commercial compounds. Therefore, a special pipe dope must be applied when wrought iron or steel pipe is used. Shellac base compounds such as gaskoloc or stalastic, and compounds such as rectorseal # 5, Clyde's or John Crane may be used.

- All piping should be cleaned of dirt and scale by hammering on the outside of the pipe and blowing out the loose dirt and scale. Before initial start-up, be sure that all of the gas lines external to the unit have been purged of air.
- The gas supply should be a separate line and installed in accordance with all safety codes as prescribed under Limitations, shown on Page 3. After the gas connections

have been completed, open the main shut-off valve admitting normal gas pressure to the mains. Check all joints for leaks with soap solution or other material suitable for the purpose. NEVER USE A FLAME.

WARNING

FIRE OR EXPLOSION HAZARD

Failure to follow the safety warning exactly could result in serious injury, death or property damage.

Never test for gas leaks with an open flame. Use a commercially available soap solution made specifically for the detection of leaks to check all connections. A fire or explosion may result causing property damage, personal injury or loss of life.

- The furnace must be isolated from the gas supply piping system by closing its individual manual shut-off valve before conducting any pressure testing of the gas supply piping system at test pressures equal to or less than 1/2 psig (3.48 kPa).

Flue Vent Hood

The flue vent hood with screen is shipped loose. This hood must be installed to assure proper unit operation. The hood must be fastened to the outside of the side gas control/electrical compartment with the screws provided in the bag attached to the inside of the gas control/electrical compartment, see Figure 12.

WARNING

Flue hood surfaces may be hot.

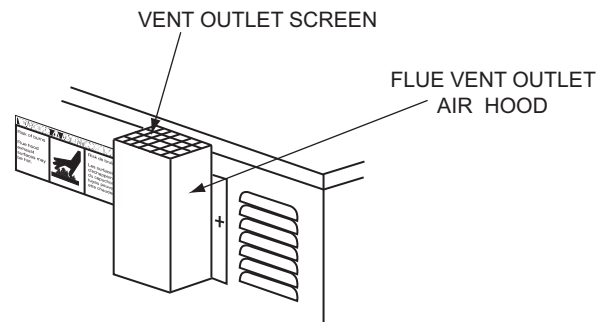

Figure 12: Flue Vent Outlet Air Hood

CAUTION

The flue exhaust hood must be properly installed and within the recommended clearances. Further communications and action must be given to the home or building owner(s) to eliminate any unauthorized human contact around this area during the heating cycle. Flue hood surface and the immediate area reach high temperatures during the heating cycle.

Table 11: Natural Gas Application Data-Single Stage

Available On Models	Input (MBH) ¹	Output (MBH)	Gas Rate ² Ft. ³ /Hr.	Number of Burners	Temp. Rise °F At Full Input ³	
					Min.	Max.
2,3 Ton	45	36	42	2	25	55
2 Ton	70	56	65	3	30	60
3 Ton	70	56	65	3	25	55
4, 5 Ton	80	64	74	3	25	55
3 Ton	90	72	84	4	30	60
4, 5 Ton	108	87	100	4	35	65
4, 5 Ton	135	108	126	5	45	75

1. Heating capacity valid for elevations up to 2000 feet above sea level. For elevations above 2,000 feet, rated capacity should be reduced by 4% for each 1,000 feet above sea level.
2. Based on 1075 BTU/Ft.³.
3. The air flow must be adequate to obtain a temperature rise within the range shown. Continuous return air temperature should not be below 55°F.

Table 12: Natural Gas Application Data-Two Stage

Available On Models	Input (MBH) ¹ High Fire/Low Fire	Output (MBH) High Fire/Low Fire	Gas Rate ² Ft. ³ /Hr. High Fire/Low Fire	Number of Burners	Temp. Rise °F At Full Input ³	
					Min.	Max.
2 Ton	70 / 45.5	56 / 36.4	65 / 42	3	30	60
3 Ton	70 / 45.5	56 / 36.4	65 / 42	3	25	55
3 Ton	90 / 58.5	72 / 46.8	84 / 54	4	30	60
4, 5 Ton	108 / 70.2	87 / 56.2	100 / 65	4	35	65
4, 5 Ton	135 / 87.75	108 / 70.2	126 / 82	5	45	75

1. Heating capacity valid for elevations up to 2000 feet above sea level. For elevations above 2,000 feet, rated capacity should be reduced by 4% for each 1,000 feet above sea level.
2. Based on 1075 BTU/Ft.³.
3. The air flow must be adequate to obtain a temperature rise within the range shown. Continuous return air temperature should not be below 55°F.

Table 13: Propane¹ (LP) Gas Application Data-Single Stage

Available On Models	Input Capacity (Mbh) ²	Output Capacity (Mbh)	Gas Rate ³ Ft. ³ /Hr.	Number of Burners	Temp. Rise °F At Full Input ⁴	
					Min.	Max.
2,3 Ton	45	36	18	2	25	55
2 Ton	70	56	28	3	30	60
3 Ton	70	56	28	3	25	55
4, 5 Ton	80	64	32	3	25	55
3 Ton	90	72	36	4	30	60
4, 5 Ton	108	87	43	4	35	65
4, 5 Ton	135	108	54	5	45	75

1. Propane applications are accomplished by field installation of a Propane Conversion Accessory, Model 1NP0807 for 2 and 3 Ton units with 33-1/2" tall cabinets and Model 1NP0808 for 4 and 5 Ton units with 41-1/2" tall cabinets.
2. Heating capacity valid for elevations up to 2,000 feet above sea level. For elevations above 2,000 feet, rated capacity should be reduced by 4% for each 1,000 feet above sea level.
3. Based on 2500 BTU/Ft.³.
4. The air flow must be adequate to obtain a temperature rise within the range shown. Continuous return air temperature should not be below 55°F.

Table 14: Propane¹ (LP) Gas Application Data-Two Stage

Available On Models	Input Capacity (Mbh) ² High Fire/Low Fire	Output Capacity (Mbh) High Fire/Low Fire	Gas Rate ³ Ft. ³ /Hr. High Fire/Low Fire	Number of Burners	Temp. Rise °F At Full Input ⁴	
					Min.	Max.
2 Ton	70 / 45.5	56 / 36.4	28 / 18.2	3	30	60
3 Ton	70 / 45.5	56 / 36.4	28 / 18.2	3	25	55
3 Ton	90 / 58.5	72 / 46.8	36 / 23.4	4	30	60
4, 5 Ton	108 / 70.2	87 / 56.2	43 / 27.95	4	35	65
4, 5 Ton	135 / 87.75	108 / 70.2	54 / 35.1	5	45	75

1. Propane applications are accomplished by field installation of a Propane Conversion Accessory, Model 1NP0809 for 2 and 3 Ton units with 33-1/2" tall cabinets and Model 1NP0810 for 4 and 5 Ton units with 41-1/2" tall cabinets.
2. Heating capacity valid for elevations up to 2,000 feet above sea level. For elevations above 2,000 feet, rated capacity should be reduced by 4% for each 1,000 feet above sea level.
3. Based on 2500 BTU/Ft.³.
4. The air flow must be adequate to obtain a temperature rise within the range shown. Continuous return air temperature should not be below 55°F.

Airflow Performance

Table 15: Side Duct Application

Size (Tons)	Mode		Thermostat Input	Speed Tap	CFM	External Static Pressure (Inch Water Gauge)								
						0.2	0.3	0.4	0.5	0.6	0.7	0.8	0.9	1.0
						Watts	Watts	Watts	Watts	Watts	Watts	Watts	Watts	Watts
024 (2.0)	Cool	High	Y1	COOL-A	800	177	204	232	261	290	320	350	382	414
			Y1	COOL-B	600	100	122	145	169	194	221	249	279	310
			Y1	COOL-C	700	134	159	184	211	238	265	293	323	352
			Y1	COOL-D	900	229	258	288	319	351	385	420	457	494
	Heat	N036	W1	HEAT-A	670	123	147	172	197	224	251	-	-	-
			W1	HEAT-B	730	146	172	198	225	252	280	-	-	-
			W1	HEAT-C	790	173	199	227	255	284	314	-	-	-
			W1	HEAT-D	850	202	230	259	289	319	351	-	-	-
		N056	W1	HEAT-A	940	253	281	312	344	378	-	-	-	-
			W1	HEAT-B	975	274	303	334	368	403	-	-	-	-
			W1	HEAT-C	1000	290	319	351	385	422	-	-	-	-
			W1	HEAT-D	1050	324	353	386	422	461	-	-	-	-
		D056	W1	HEAT-A	670	123	147	172	197	224	-	-	-	-
			W1	HEAT-B	690	130	155	180	206	233	-	-	-	-
			W1	HEAT-C	710	138	163	189	215	242	-	-	-	-
			W1	HEAT-D	750	155	181	207	235	262	-	-	-	-
			W1+W2	HEAT-A	940	253	281	312	344	378	-	-	-	-
			W1+W2	HEAT-B	970	271	300	331	364	400	-	-	-	-
			W1+W2	HEAT-C	1000	290	319	351	385	422	-	-	-	-
			W1+W2	HEAT-D	1050	324	353	386	422	461	-	-	-	-
030 (2.5)	Cool	High	Y1	COOL-A	900	222	254	291	323	340	381	431	462	516
			Y1	COOL-B	1000	271	306	360	397	433	469	508	554	571
			Y1	COOL-C	1125	367	411	445	500	533	588	625	647	665
			Y1	COOL-D	1250	472	522	587	628	660	686	701	720	736
	Heat	N036	W1	HEAT-A	670	121	152	180	205	228	257	-	-	-
			W1	HEAT-B	730	143	180	204	225	260	286	-	-	-
			W1	HEAT-C	790	172	205	237	267	296	329	-	-	-
			W1	HEAT-D	850	195	235	263	310	324	366	-	-	-
		N056	W1	HEAT-A	1050	297	341	385	427	469	-	-	-	-
			W1	HEAT-B	1135	379	417	455	496	536	-	-	-	-
			W1	HEAT-C	1220	448	493	537	586	635	-	-	-	-
			W1	HEAT-D	1300	514	562	610	655	700	-	-	-	-
		D056	W1	HEAT-A	680	130	161	189	214	237	-	-	-	-
			W1	HEAT-B	735	150	185	212	229	269	-	-	-	-
			W1	HEAT-C	790	172	205	237	267	296	-	-	-	-
			W1	HEAT-D	840	204	244	272	319	333	-	-	-	-
			W1+W2	HEAT-A	1050	297	341	385	427	469	-	-	-	-
			W1+W2	HEAT-B	1135	379	417	455	496	536	-	-	-	-
			W1+W2	HEAT-C	1220	448	493	537	586	635	-	-	-	-
			W1+W2	HEAT-D	1300	514	562	610	655	700	-	-	-	-

Table 15: Side Duct Application (Continued)

Size (Tons)	Mode		Thermostat Input	Speed Tap	CFM	External Static Pressure (Inch Water Gauge)									
						0.2	0.3	0.4	0.5	0.6	0.7	0.8	0.9	1.0	
						Watts	Watts	Watts	Watts	Watts	Watts	Watts	Watts	Watts	
036 (3.0)	Cool	High	Y1	COOL-A	1100	363	410	459	509	559	611	664	719	773	
			Y1	COOL-B	1050	328	375	424	474	524	576	629	684	738	
			Y1	COOL-C	1200	439	489	541	595	652	710	771	835	900	
			Y1	COOL-D	1350	576	626	680	737	798	863	932	1005	-	
	Heat	N036	W1	HEAT-A	670	162	194	227	258	289	320	-	-	-	
			W1	HEAT-B	730	177	213	248	283	318	352	-	-	-	
			W1	HEAT-C	790	196	235	274	312	350	388	-	-	-	
			W1	HEAT-D	850	220	261	303	344	385	426	-	-	-	
		N056	W1	HEAT-A	1050	328	375	424	474	524	-	-	-	-	
			W1	HEAT-B	1135	388	437	488	540	594	-	-	-	-	
			W1	HEAT-C	1220	456	506	558	613	670	-	-	-	-	
			W1	HEAT-D	1300	528	578	631	687	747	-	-	-	-	
		D056	W1	HEAT-A	680	164	197	230	262	294	-	-	-	-	
			W1	HEAT-B	735	178	215	250	286	321	-	-	-	-	
			W1	HEAT-C	790	196	235	274	312	350	-	-	-	-	
			W1	HEAT-D	840	216	257	297	338	379	-	-	-	-	
			W1+W2	HEAT-A	1050	328	375	424	474	524	-	-	-	-	
			W1+W2	HEAT-B	1140	392	441	491	544	598	-	-	-	-	
			W1+W2	HEAT-C	1220	456	506	558	613	670	-	-	-	-	
			W1+W2	HEAT-D	1300	528	578	631	687	747	-	-	-	-	
		N072	W1	HEAT-A	1200	439	489	541	595	-	-	-	-	-	
			W1	HEAT-B	1300	528	578	631	687	-	-	-	-	-	
			W1	HEAT-C	1400	628	677	731	789	-	-	-	-	-	
			W1	HEAT-D	1475	710	759	812	871	-	-	-	-	-	
		D072	W1	HEAT-A	790	196	235	274	312	-	-	-	-	-	
			W1	HEAT-B	855	222	264	305	347	-	-	-	-	-	
			W1	HEAT-C	920	252	296	341	385	-	-	-	-	-	
			W1	HEAT-D	975	282	328	374	421	-	-	-	-	-	
W1+W2			HEAT-A	1200	439	489	541	595	-	-	-	-	-		
W1+W2			HEAT-B	1300	528	578	631	687	-	-	-	-	-		
042 (3.5)		Cool	High	Y1	COOL-A	1400	466	513	561	611	663	715	770	826	882
				Y1	COOL-B	1350	430	476	523	571	621	672	718	766	815
	Y1			COOL-C	1500	544	596	648	702	758	815	867	921	975	
	Y1			COOL-D	1600	630	687	745	804	864	926	988	1052	1116	
	Heat	N065	W1	HEAT-A	1200	330	373	416	461	507	554	-	-	-	
			W1	HEAT-B	1300	394	439	484	531	579	629	-	-	-	
			W1	HEAT-C	1400	466	513	561	611	663	715	-	-	-	
			W1	HEAT-D	1500	544	596	648	702	758	815	-	-	-	
		N090	W1	HEAT-A	1325	412	456	503	550	599	649	-	-	-	
			W1	HEAT-B	1400	466	513	561	611	663	715	-	-	-	
			W1	HEAT-C	1500	544	596	648	702	758	815	-	-	-	
			W1	HEAT-D	1600	630	687	745	804	864	926	-	-	-	
		D090	W1	HEAT-A	870	168	215	261	306	350	393	-	-	-	
			W1	HEAT-B	920	188	233	278	322	366	409	-	-	-	
			W1	HEAT-C	985	216	260	303	347	391	434	-	-	-	
			W1	HEAT-D	1050	247	290	333	376	420	464	-	-	-	
			W1+W2	HEAT-A	1330	415	460	506	554	603	653	-	-	-	
			W1+W2	HEAT-B	1400	466	513	561	611	663	715	-	-	-	
		W1+W2	HEAT-C	1500	544	596	648	702	758	815	-	-	-		
		W1+W2	HEAT-D	1600	630	687	745	804	864	926	-	-	-		

Table 15: Side Duct Application (Continued)

Size (Tons)	Mode		Thermostat Input	Speed Tap	CFM	External Static Pressure (Inch Water Gauge)										
						0.2	0.3	0.4	0.5	0.6	0.7	0.8	0.9	1.0		
						Watts	Watts	Watts	Watts	Watts	Watts	Watts	Watts	Watts		
048 (4.0)	Cool	High	Y1	COOL-A	1500	544	596	648	702	758	815	867	921	975		
			Y1	COOL-B	1400	466	513	561	611	663	715	770	826	882		
			Y1	COOL-C	1600	630	687	745	804	864	926	988	1052	1116		
			Y1	COOL-D	1700	723	787	851	916	982	1049	1116	1185	1247		
	Heat	N065	W1	HEAT-A	1200	330	373	416	461	507	554	-	-	-		
			W1	HEAT-B	1300	394	439	484	531	579	629	-	-	-		
			W1	HEAT-C	1400	466	513	561	611	663	715	-	-	-		
			W1	HEAT-D	1500	544	596	648	702	758	815	-	-	-		
		N090	W1	HEAT-A	1325	412	456	503	550	599	649	-	-	-		
			W1	HEAT-B	1400	466	513	561	611	663	715	-	-	-		
			W1	HEAT-C	1500	544	596	648	702	758	815	-	-	-		
			W1	HEAT-D	1600	630	687	745	804	864	926	-	-	-		
		D090	W1	HEAT-A	870	168	215	261	306	350	393	-	-	-		
			W1	HEAT-B	920	188	233	278	322	366	409	-	-	-		
			W1	HEAT-C	985	216	260	303	347	391	434	-	-	-		
			W1	HEAT-D	1050	247	290	333	376	420	464	-	-	-		
			W1+W2	HEAT-A	1330	415	460	506	554	603	653	-	-	-		
			W1+W2	HEAT-B	1400	466	513	561	611	663	715	-	-	-		
			W1+W2	HEAT-C	1500	544	596	648	702	758	815	-	-	-		
			W1+W2	HEAT-D	1600	630	687	745	804	864	926	-	-	-		
		N110	W1	HEAT-A	1450	504	553	604	656	-	-	-	-	-		
			W1	HEAT-B	1500	544	596	648	702	-	-	-	-	-		
			W1	HEAT-C	1600	630	687	745	804	-	-	-	-	-		
			W1	HEAT-D	1700	723	787	851	916	-	-	-	-	-		
		D110	W1	HEAT-A	940	196	241	285	329	-	-	-	-	-		
			W1	HEAT-B	970	209	253	297	341	-	-	-	-	-		
			W1	HEAT-C	1050	247	290	333	376	-	-	-	-	-		
			W1	HEAT-D	1100	273	315	358	402	-	-	-	-	-		
			W1+W2	HEAT-A	1450	504	553	604	656	-	-	-	-	-		
			W1+W2	HEAT-B	1500	544	596	648	702	-	-	-	-	-		
			W1+W2	HEAT-C	1600	630	687	745	804	-	-	-	-	-		
			W1+W2	HEAT-D	1700	723	787	851	916	-	-	-	-	-		
		060 (5.0)	Cool	High	Y1	COOL-A	1550	438	480	522	609	696	736	803	866	930
					Y1	COOL-B	1650	510	554	598	690	782	826	896	963	1031
					Y1	COOL-C	1750	589	635	682	778	873	924	995	1066	1137
					Y1	COOL-D	2000	822	875	927	1027	1128	1198	-	-	-
			Heat	N065	W1	HEAT-A	1200	251	285	319	382	445	475	-	-	-
					W1	HEAT-B	1300	295	331	367	438	509	541	-	-	-
					W1	HEAT-C	1400	346	385	423	501	579	613	-	-	-
					W1	HEAT-D	1500	405	446	487	572	656	693	-	-	-
N090	W1			HEAT-A	1325	307	344	381	453	526	558	-	-	-		
	W1			HEAT-B	1400	346	385	423	501	579	613	-	-	-		
	W1			HEAT-C	1500	405	446	487	572	656	693	-	-	-		
	W1			HEAT-D	1600	473	516	559	649	738	780	-	-	-		
D090	W1			HEAT-A	870	165	191	218	246	275	307	-	-	-		
	W1			HEAT-B	920	172	200	228	262	296	328	-	-	-		
	W1			HEAT-C	985	185	214	243	285	326	357	-	-	-		
	W1			HEAT-D	1050	201	232	263	311	359	389	-	-	-		
	W1+W2			HEAT-A	1330	309	346	383	456	530	562	-	-	-		
	W1+W2			HEAT-B	1400	346	385	423	501	579	613	-	-	-		
	W1+W2			HEAT-C	1500	405	446	487	572	656	693	-	-	-		
	W1+W2			HEAT-D	1600	473	516	559	649	738	780	-	-	-		
N110	W1			HEAT-A	1450	375	414	454	536	617	652	-	-	-		
	W1			HEAT-B	1500	405	446	487	572	656	693	-	-	-		
	W1			HEAT-C	1600	473	516	559	649	738	780	-	-	-		
	W1			HEAT-D	1700	548	594	639	733	827	874	-	-	-		
D110	W1			HEAT-A	940	176	204	232	269	305	336	-	-	-		
	W1			HEAT-B	985	185	214	243	285	326	357	-	-	-		
	W1			HEAT-C	1035	197	227	258	305	351	381	-	-	-		
	W1			HEAT-D	1100	216	248	279	333	386	416	-	-	-		
	W1+W2			HEAT-A	1450	375	414	454	536	617	652	-	-	-		
	W1+W2			HEAT-B	1500	405	446	487	572	656	693	-	-	-		
	W1+W2			HEAT-C	1600	473	516	559	649	738	780	-	-	-		
	W1+W2			HEAT-D	1700	548	594	639	733	827	874	-	-	-		

Table 16: Bottom Duct Application

Size (Tons)	Mode		Thermostat Input	Speed Tap	CFM	External Static Pressure (Inch Water Gauge)								
						0.2	0.3	0.4	0.5	0.6	0.7	0.8	0.9	1.0
						Watts	Watts	Watts	Watts	Watts	Watts	Watts	Watts	Watts
024 (2.0)	Cool	High	Y1	COOL-A	800	177	204	232	261	290	320	350	382	414
			Y1	COOL-B	600	100	122	145	169	194	221	249	279	310
			Y1	COOL-C	700	134	159	184	211	238	265	293	323	352
			Y1	COOL-D	900	229	258	288	319	351	385	420	457	494
	Heat	N036	W1	HEAT-A	670	123	147	172	197	224	251	-	-	-
			W1	HEAT-B	730	146	172	198	225	252	280	-	-	-
			W1	HEAT-C	790	173	199	227	255	284	314	-	-	-
			W1	HEAT-D	850	202	230	259	289	319	351	-	-	-
		N056	W1	HEAT-A	940	253	281	312	344	378	-	-	-	-
			W1	HEAT-B	975	274	303	334	368	403	-	-	-	-
			W1	HEAT-C	1000	290	319	351	385	422	-	-	-	-
			W1	HEAT-D	1050	324	353	386	422	461	-	-	-	-
		D056	W1	HEAT-A	670	123	147	172	197	224	-	-	-	-
			W1	HEAT-B	690	130	155	180	206	233	-	-	-	-
			W1	HEAT-C	710	138	163	189	215	242	-	-	-	-
			W1	HEAT-D	750	155	181	207	235	262	-	-	-	-
			W1+W2	HEAT-A	940	253	281	312	344	378	-	-	-	-
			W1+W2	HEAT-B	970	271	300	331	364	400	-	-	-	-
			W1+W2	HEAT-C	1000	290	319	351	385	422	-	-	-	-
			W1+W2	HEAT-D	1050	324	353	386	422	461	-	-	-	-
030 (2.5)	Cool	High	Y1	COOL-A	900	222	254	291	323	340	381	431	462	516
			Y1	COOL-B	1000	271	306	360	397	433	469	508	554	571
			Y1	COOL-C	1125	367	411	445	500	533	588	625	647	665
			Y1	COOL-D	1250	472	522	587	628	660	686	701	720	736
	Heat	N036	W1	HEAT-A	670	121	152	180	205	228	257	-	-	-
			W1	HEAT-B	730	143	180	204	225	260	286	-	-	-
			W1	HEAT-C	790	172	205	237	267	296	329	-	-	-
			W1	HEAT-D	850	195	235	263	310	324	366	-	-	-
		N056	W1	HEAT-A	1050	297	341	385	427	469	-	-	-	-
			W1	HEAT-B	1135	379	417	455	496	536	-	-	-	-
			W1	HEAT-C	1220	448	493	537	586	635	-	-	-	-
			W1	HEAT-D	1300	514	562	610	655	700	-	-	-	-
		D056	W1	HEAT-A	680	130	161	189	214	237	-	-	-	-
			W1	HEAT-B	735	150	185	212	229	269	-	-	-	-
			W1	HEAT-C	790	172	205	237	267	296	-	-	-	-
			W1	HEAT-D	840	204	244	272	319	333	-	-	-	-
			W1+W2	HEAT-A	1050	297	341	385	427	469	-	-	-	-
			W1+W2	HEAT-B	1135	379	417	455	496	536	-	-	-	-
			W1+W2	HEAT-C	1220	448	493	537	586	635	-	-	-	-
			W1+W2	HEAT-D	1300	514	562	610	655	700	-	-	-	-

Table 16: Bottom Duct Application (Continued)

Size (Tons)	Mode		Thermostat Input	Speed Tap	CFM	External Static Pressure (Inch Water Gauge)								
						0.2	0.3	0.4	0.5	0.6	0.7	0.8	0.9	1.0
						Watts	Watts	Watts	Watts	Watts	Watts	Watts	Watts	Watts
036 (3.0)	Cool	High	Y1	COOL-A	1100	363	410	459	509	559	611	664	719	773
			Y1	COOL-B	1050	328	375	424	474	524	576	629	684	738
			Y1	COOL-C	1200	439	489	541	595	652	710	771	835	900
			Y1	COOL-D	1350	576	626	680	737	798	863	932	1005	-
	Heat	N036	W1	HEAT-A	670	162	194	227	258	289	320	-	-	-
			W1	HEAT-B	730	177	213	248	283	318	352	-	-	-
			W1	HEAT-C	790	196	235	274	312	350	388	-	-	-
			W1	HEAT-D	850	220	261	303	344	385	426	-	-	-
		N056	W1	HEAT-A	1050	328	375	424	474	524	-	-	-	-
			W1	HEAT-B	1135	388	437	488	540	594	-	-	-	-
			W1	HEAT-C	1220	456	506	558	613	670	-	-	-	-
			W1	HEAT-D	1300	528	578	631	687	747	-	-	-	-
		D056	W1	HEAT-A	680	164	197	230	262	294	-	-	-	-
			W1	HEAT-B	735	178	215	250	286	321	-	-	-	-
			W1	HEAT-C	790	196	235	274	312	350	-	-	-	-
			W1	HEAT-D	840	216	257	297	338	379	-	-	-	-
			W1+W2	HEAT-A	1050	328	375	424	474	524	-	-	-	-
			W1+W2	HEAT-B	1140	392	441	491	544	598	-	-	-	-
			W1+W2	HEAT-C	1220	456	506	558	613	670	-	-	-	-
			W1+W2	HEAT-D	1300	528	578	631	687	747	-	-	-	-
		N072	W1	HEAT-A	1200	439	489	541	595	-	-	-	-	-
			W1	HEAT-B	1300	528	578	631	687	-	-	-	-	-
			W1	HEAT-C	1400	628	677	731	789	-	-	-	-	-
			W1	HEAT-D	1475	710	759	812	871	-	-	-	-	-
		D072	W1	HEAT-A	790	196	235	274	312	-	-	-	-	-
			W1	HEAT-B	855	222	264	305	347	-	-	-	-	-
			W1	HEAT-C	920	252	296	341	385	-	-	-	-	-
			W1	HEAT-D	975	282	328	374	421	-	-	-	-	-
W1+W2			HEAT-A	1200	439	489	541	595	-	-	-	-	-	
W1+W2			HEAT-B	1300	528	578	631	687	-	-	-	-	-	
W1+W2			HEAT-C	1400	628	677	731	789	-	-	-	-	-	
W1+W2			HEAT-D	1480	716	764	818	877	-	-	-	-	-	
042 (3.5)	Cool	High	Y1	COOL-A	1400	466	513	561	611	663	715	770	826	882
			Y1	COOL-B	1350	430	476	523	571	621	672	718	766	815
			Y1	COOL-C	1500	544	596	648	702	758	815	867	921	975
			Y1	COOL-D	1600	630	687	745	804	864	926	988	1052	1116
	Heat	N065	W1	HEAT-A	1200	330	373	416	461	507	554	-	-	-
			W1	HEAT-B	1300	394	439	484	531	579	629	-	-	-
			W1	HEAT-C	1400	466	513	561	611	663	715	-	-	-
			W1	HEAT-D	1500	544	596	648	702	758	815	-	-	-
		N090	W1	HEAT-A	1325	412	456	503	550	599	649	-	-	-
			W1	HEAT-B	1400	466	513	561	611	663	715	-	-	-
			W1	HEAT-C	1500	544	596	648	702	758	815	-	-	-
			W1	HEAT-D	1600	630	687	745	804	864	926	-	-	-
		D090	W1	HEAT-A	870	168	215	261	306	350	393	-	-	-
			W1	HEAT-B	920	188	233	278	322	366	409	-	-	-
			W1	HEAT-C	985	216	260	303	347	391	434	-	-	-
			W1	HEAT-D	1050	247	290	333	376	420	464	-	-	-
			W1+W2	HEAT-A	1330	415	460	506	554	603	653	-	-	-
			W1+W2	HEAT-B	1400	466	513	561	611	663	715	-	-	-
			W1+W2	HEAT-C	1500	544	596	648	702	758	815	-	-	-
			W1+W2	HEAT-D	1600	630	687	745	804	864	926	-	-	-

Table 16: Bottom Duct Application (Continued)

Size (Tons)	Mode		Thermostat Input	Speed Tap	CFM	External Static Pressure (Inch Water Gauge)										
						0.2	0.3	0.4	0.5	0.6	0.7	0.8	0.9	1.0		
						Watts	Watts	Watts	Watts	Watts	Watts	Watts	Watts	Watts		
048 (4.0)	Cool	High	Y1	COOL-A	1500	544	596	648	702	758	815	867	921	975		
			Y1	COOL-B	1400	466	513	561	611	663	715	770	826	882		
			Y1	COOL-C	1600	630	687	745	804	864	926	988	1052	1116		
			Y1	COOL-D	1700	723	787	851	916	982	1049	1116	1185	1247		
	Heat	N065	W1	HEAT-A	1200	330	373	416	461	507	554	-	-	-		
			W1	HEAT-B	1300	394	439	484	531	579	629	-	-	-		
			W1	HEAT-C	1400	466	513	561	611	663	715	-	-	-		
			W1	HEAT-D	1500	544	596	648	702	758	815	-	-	-		
		N090	W1	HEAT-A	1325	412	456	503	550	599	649	-	-	-		
			W1	HEAT-B	1400	466	513	561	611	663	715	-	-	-		
			W1	HEAT-C	1500	544	596	648	702	758	815	-	-	-		
			W1	HEAT-D	1600	630	687	745	804	864	926	-	-	-		
		D090	W1	HEAT-A	870	168	215	261	306	350	393	-	-	-		
			W1	HEAT-B	920	188	233	278	322	366	409	-	-	-		
			W1	HEAT-C	985	216	260	303	347	391	434	-	-	-		
			W1	HEAT-D	1050	247	290	333	376	420	464	-	-	-		
			W1+W2	HEAT-A	1330	415	460	506	554	603	653	-	-	-		
			W1+W2	HEAT-B	1400	466	513	561	611	663	715	-	-	-		
			W1+W2	HEAT-C	1500	544	596	648	702	758	815	-	-	-		
			W1+W2	HEAT-D	1600	630	687	745	804	864	926	-	-	-		
		N110	W1	HEAT-A	1450	504	553	604	656	-	-	-	-	-		
			W1	HEAT-B	1500	544	596	648	702	-	-	-	-	-		
			W1	HEAT-C	1600	630	687	745	804	-	-	-	-	-		
			W1	HEAT-D	1700	723	787	851	916	-	-	-	-	-		
		D110	W1	HEAT-A	940	196	241	285	329	-	-	-	-	-		
			W1	HEAT-B	970	209	253	297	341	-	-	-	-	-		
			W1	HEAT-C	1050	247	290	333	376	-	-	-	-	-		
			W1	HEAT-D	1100	273	315	358	402	-	-	-	-	-		
			W1+W2	HEAT-A	1450	504	553	604	656	-	-	-	-	-		
			W1+W2	HEAT-B	1500	544	596	648	702	-	-	-	-	-		
			W1+W2	HEAT-C	1600	630	687	745	804	-	-	-	-	-		
			W1+W2	HEAT-D	1700	723	787	851	916	-	-	-	-	-		
		060 (5.0)	Cool	High	Y1	COOL-A	1550	438	480	522	609	696	736	803	866	930
					Y1	COOL-B	1650	510	554	598	690	782	826	896	963	1031
					Y1	COOL-C	1750	589	635	682	778	873	924	995	1066	1137
					Y1	COOL-D	2000	822	875	927	1027	1128	1198	-	-	-
			Heat	N065	W1	HEAT-A	1200	251	285	319	382	445	475	-	-	-
					W1	HEAT-B	1300	295	331	367	438	509	541	-	-	-
					W1	HEAT-C	1400	346	385	423	501	579	613	-	-	-
					W1	HEAT-D	1500	405	446	487	572	656	693	-	-	-
				N090	W1	HEAT-A	1325	307	344	381	453	526	558	-	-	-
					W1	HEAT-B	1400	346	385	423	501	579	613	-	-	-
					W1	HEAT-C	1500	405	446	487	572	656	693	-	-	-
					W1	HEAT-D	1600	473	516	559	649	738	780	-	-	-
D090				W1	HEAT-A	870	165	191	218	246	275	307	-	-	-	
				W1	HEAT-B	920	172	200	228	262	296	328	-	-	-	
				W1	HEAT-C	985	185	214	243	285	326	357	-	-	-	
				W1	HEAT-D	1050	201	232	263	311	359	389	-	-	-	
	W1+W2			HEAT-A	1330	309	346	383	456	530	562	-	-	-		
	W1+W2			HEAT-B	1400	346	385	423	501	579	613	-	-	-		
	W1+W2			HEAT-C	1500	405	446	487	572	656	693	-	-	-		
	W1+W2			HEAT-D	1600	473	516	559	649	738	780	-	-	-		
N110	W1			HEAT-A	1450	375	414	454	536	617	652	-	-	-		
	W1			HEAT-B	1500	405	446	487	572	656	693	-	-	-		
	W1			HEAT-C	1600	473	516	559	649	738	780	-	-	-		
	W1			HEAT-D	1700	548	594	639	733	827	874	-	-	-		
D110	W1			HEAT-A	940	176	204	232	269	305	336	-	-	-		
	W1			HEAT-B	985	185	214	243	285	326	357	-	-	-		
	W1			HEAT-C	1035	197	227	258	305	351	381	-	-	-		
	W1			HEAT-D	1100	216	248	279	333	386	416	-	-	-		
	W1+W2			HEAT-A	1450	375	414	454	536	617	652	-	-	-		
	W1+W2			HEAT-B	1500	405	446	487	572	656	693	-	-	-		
	W1+W2			HEAT-C	1600	473	516	559	649	738	780	-	-	-		
	W1+W2			HEAT-D	1700	548	594	639	733	827	874	-	-	-		

Table 17: Additional Static Resistance

Size (Tons)	CFM	Wet Indoor Coil	Economizer ¹	Filter/Frame Kit	Electric Heat
024 (2.0)	500	0.01	0.00	0.01	-
	600	0.01	0.00	0.02	-
	700	0.01	0.00	0.04	-
	800	0.02	0.01	0.06	-
	900	0.03	0.01	0.08	-
	1000	0.04	0.01	0.10	-
	1100	0.05	0.01	0.13	-
	1200	0.06	0.02	0.16	-
030 (2.5)	700	0.01	0.00	0.04	-
	800	0.02	0.01	0.06	-
	900	0.03	0.01	0.08	-
	1000	0.04	0.01	0.10	-
	1100	0.05	0.01	0.13	-
	1200	0.06	0.02	0.16	-
036 (3.0)	1300	0.07	0.03	0.17	-
	700	0.01	0.00	0.04	-
	800	0.02	0.01	0.06	-
	900	0.03	0.01	0.08	-
	1000	0.04	0.01	0.10	-
	1100	0.05	0.01	0.13	-
	1200	0.06	0.02	0.16	-
	1300	0.07	0.03	0.17	-
042 (3.5)	1400	0.08	0.04	0.18	-
	1100	0.02	0.02	0.04	-
	1200	0.03	0.02	0.04	-
	1300	0.04	0.02	0.05	-
	1400	0.05	0.03	0.05	-
	1500	0.06	0.04	0.06	-
	1600	0.07	0.04	0.07	-
	1700	0.07	0.04	0.08	-
	1800	0.08	0.04	0.09	-
	1900	0.09	0.05	0.10	-
048 (4.0)	2000	0.09	0.05	0.11	-
	1100	0.02	0.02	0.04	-
	1200	0.03	0.02	0.04	-
	1300	0.04	0.02	0.05	-
	1400	0.05	0.03	0.05	-
	1500	0.06	0.04	0.06	-
	1600	0.07	0.04	0.07	-
	1700	0.07	0.04	0.08	-
	1800	0.08	0.04	0.09	-
	1900	0.09	0.05	0.10	-
060 (5.0)	2000	0.09	0.05	0.11	-
	1100	0.02	0.02	0.04	-
	1200	0.03	0.02	0.04	-
	1300	0.04	0.02	0.05	-
	1400	0.05	0.03	0.05	-
	1500	0.06	0.04	0.06	-
	1600	0.07	0.04	0.07	-
	1700	0.07	0.04	0.08	-
	1800	0.08	0.04	0.09	-
	1900	0.09	0.05	0.10	-

1. The pressure drop through the economizer is greater for 100% outdoor air than for 100% return air. If the resistance of the return air duct is less than 0.25 IWG, the unit will deliver less CFM during full economizer operation.

Table 18: Indoor Blower Specifications

Size (Tons)	Motor				
	HP	RPM	Eff.	SF	Frame
024 (2.0)	1/2	1050	0.8	1.0	48
030 (2.5)	3/4	1050	0.8	1.0	48
036 (3.0)	3/4	1050	0.8	1.0	48
042 (3.5)	3/4	1050	0.8	1.0	48
048 (4.0)	1	1050	0.8	1.0	48
060 (5.0)	1	1050	0.8	1.0	48

Blower Speed Selection

The variable speed blowers are designed to deliver constant CFM regardless of the external static pressure (ESP) in the ductwork. Therefore, if too many supply registers are closed, a filter becomes clogged, or there is a restriction in the ductwork, the motor will automatically operate at a higher speed to compensate for the higher ESP. This may result in a higher operating sound level.

These units have variable speed motors that automatically adjust to provide constant CFM from 0.2" to 0.6" w.c. static pressure. From 0.6" to 1.0" static pressure, CFM is reduced by 2% per 0.1" increase in static. Operation on duct systems with greater than 1.0" w.c. external static pressure is not recommended.

To Set Cooling CFM for DNQ Units:

Refer to Airflow Performance Tables 15 and 16 for the possible cooling speed CFM selections.

Set "COOL" and "ADJ" Jumpers on the CFM selection board as indicated in Tables 15, 16 and Figure 13.

NOTE: CFM indicator light flashes once for every 100 CFM (i.e. 12 flashes = 1200 CFM).

CAUTION

Do not change the "ADJ" tab position on the CFM selection board as this will change your cooling CFM previously selected.

To Set Delay Profile:

Every unit has multiple cooling "blower off delay" profiles to optimize system performance and efficiency. Refer to Table 19 for the regional climate in your area. Place the "DELAY" jumper tap on the CFM selection board on the appropriate pin setting.

Factory Set Gas Heat CFM:

The blower speed required for gas heat is different than for cooling. The heating CFM is factory set, but is adjustable.

The "Heat" Jumper on the CFM selection board should be set to "A" from the factory.

Fan Only CFM:

When the connection is made from "R" to "G", the fan only mode is activated. In this mode, the blower will deliver 75% of the cooling system CFM. This connection is factory set from the manufacturer, but can be field adjusted.

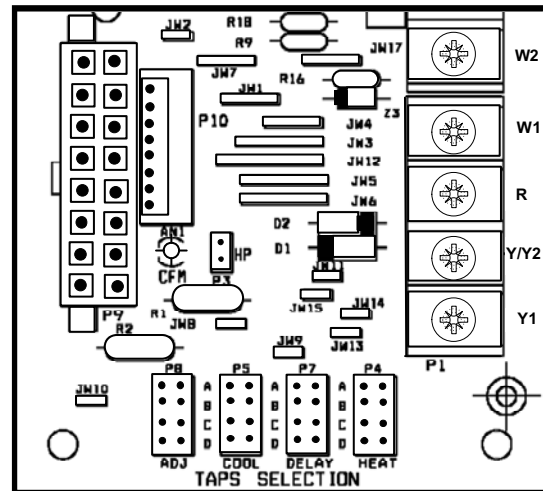
**Figure 13: Control Board Speed Tap Location****Table 19: Delay Profile**

Delay Tap	Regional Climate Type
Jumper at "A"	Standard Setting
Jumper at "B"	Humid Climate
Jumper at "C"	Dry Climate
Jumper at "D"	Temperate Climate

Operation

The unit is controlled by a conventional heating/cooling thermostat common to this class of equipment.

Heating Sequence Of Operation

Heat

The control board begins a call for heat when W1 is energized (connected to R). The control ignores W2 until pilot ignition has been established.

The control checks to see if the pressure switch is open. If the pressure switch is closed, the control board flashes "3" on the LED and waits indefinitely for it to open. When the pressure switch is sensed as open, the control begins pressure switch proving period. If the call for heat is lost, the control goes back to Standby.

Pressure Switch Proving

The control board energizes the induced draft motor (High speed for 2 stage model) and waits for the low pressure switch to close. When the low pressure switch closes, the control begins Pre-purge period. If the call for heat is lost, the control de-energizes the inducer without post-purge and returns to standby.

If the low pressure switch does not close within 10 seconds of inducer energizing, the control board flashes “2” on the LED. If the pressure switch does not close within 5 minutes of inducer energizing, the control shuts off the inducer for 30 seconds, then energizes the inducer for another 5 minute try to close the pressure switch. This cycle continues indefinitely until either the pressure switch is proved closed, or the call for heat ends.

Pre-purge

The control board monitors the low pressure switch and ensures it remains closed during pre-purge. If the pressure switch opens, the control goes back to pressure switch proving mode. The control waits for a 15 second pre-purge period, then begins the ignition trial

Ignition Trial Period

The control board energizes the pilot gas valve and spark outputs for an 85 second Ignition trial. The control de-energizes the spark when flame is sensed and enters a flame stabilization period.

If flame is not established within the ignition trial period, the control de-energizes the spark and gas valve and begins an inter-purge period before attempting another ignition trial.

If the call for heat is lost during an ignition trial period, the control immediately de-energizes spark and gas. The control runs the inducer motor through a post purge period before de-energizing.

If the pressure switch is lost during an ignition trial period, the control immediately de-energizes spark and gas. The control begins pressure switch proving before an inter-purge and re-ignition attempt.

Pilot Flame Stabilization Period

The control board de-energizes the spark output, and waits for a 2 second flame stabilization period before energizing the main gas valve.

If flame is lost during the flame stabilization period, the control board counts it as a flame loss and retries ignition or locks out flashing a “5” on the LED.

Heat Blower On Delay

The control board waits for 30 seconds and then energizes the indoor blower heat speed. Blower on delay time begins at the start of flame proving period in the trial for ignition.

If the thermostat demand for heat is removed, the control de-energizes the gas valve, energizes the blower on heat speed and initiates a post-purge and heat blower off delay.

Main Burner Operation

High Heat Warm-up

Two stage models run high heat for the first 60 seconds following Pilot Flame Stabilization period regardless of W2 demand. If W2 is not energized at the end of this 60 second period the control de-energizes the high gas output and steps the inducer to low speed. If W2 is energized the control remains on high heat.

There is no high heat warm-up on single stage models.

Low Heat

The control board keeps the pilot gas valve, main gas valve and induced draft motor energized while continuously monitoring the call for heat, low pressure switch, and flame status.

If the call for heat (W1) is lost, the control de-energizes the gas valve and begins post purge.

If low pressure switch opens, the control de-energizes the gas valve and begins pressure switch proving mode.

If flame is lost, the control de-energizes the gas valve within 2.0 second and counts the flame loss. If flame has been lost more than 16 times within the same call for heat, the control board locks out flashing “5” on the LED. If flame has been lost less than 16 times, the control attempts re-ignition after a 300 second inter-purge period.

High Heat

If the W2 terminal was energized more than 1 second before W1 at the start of the call for heat, and remains continuously energized through the call for heat, the control considers it to be connected to a single stage thermostat and implements a 10 minute Auto staging feature. The 2nd stage thermostat call is ignored until 10 minutes into steady heat (9 minutes after high heat warm-up ended).

The control recognizes a call for 2nd stage heat when W2 is energized (connected to “R”). The control energizes the high gas output and induced draft motor on high speed.

If the call for 2nd stage heat goes away and the 1st stage call remains, the control de-energizes the high gas valve, drops inducer speed to low, and returns to low heat operation.

Response to loss of W1, low pressure switch, and flame are identical to low heat operation.

Post Purge

The control board runs the induced draft motor for a 30 second post-purge period, and then de-energizes the inducer. If a call for heat occurs during post-purge, the control finishes the post-purge, drops inducer out to re-prove open pressure switch before continuing with the heat cycle.

Heat Blower Off Delay

The control board de-energizes the indoor blower motor after a delay time as selected by movable shunt (60, 90, 120 or 180 seconds). Blower timing begins when the thermostat is satisfied or heat cycle was interrupted. The control returns to standby when the blower off delay is complete.

If the thermostat call for heat returns before the blower off delay is complete, the control begins an ignition sequence with pre-purge while the blower off delay continues.

Lockout

While in lockout, the control board keeps the pilot gas valve, main gas valve and induced draft motor de-energized.

Lockouts due to failed ignition or flame losses may be reset by removing the call for heat (W1) for more than 1 second, but less than 20 seconds, or by removing power from the control for over 0.25 seconds. The control will automatically reset lockout after 60 minutes.

Lockouts due to detected internal control faults will reset after 60 minutes or power interruption.

High Temperature Limit Switch

Any time the high temperature limit switch is open the control board will run the indoor blower motor on heat speed, the inducer (on high speed for 2 stage models), de-energize the gas valve, and flash "6" on the LED. When the high temperature switch closes, the control will restart the ignition sequence beginning with pre-purge.

Rollout Switch

If the rollout switch opens for more than 0.25 seconds, the control board will run the inducer (on high speed for 2 stage models) for a post-purge period, immediately de-energize the gas valve, and flash "7" on the LED. The blower output will be energized during an open rollout condition.

If the rollout switch closes, the control shall remain locked out until power removed or "W" is removed.

Rollout switch lockout shall not reset automatically.

Power Interruptions

Power interruptions of any duration shall not cause lockout or any operation requiring manual intervention.

Flame present with Gas off

If flame is sensed for longer than 4.0 seconds during a period when the gas valve should be closed, the control will enter lockout flashing "8" on the LED. The control will turn on the inducer blower while the flame is present.

Gas Valve Stuck Open or Closed

If either or both Pilot and Main Gas valve outputs are sensed to be off for more than 1 second when commanded to be on, the control board shuts off all outputs and enters a hard lockout flashing "9" on the LED.

If the Pilot valve or Main valve output is sensed to be energized for more than 1 second when commanded to be off, the control de-energizes the induced draft motor (if flame is not present) to attempt to open the pressure switch to de-energize the gas valve. If the pilot or main gas valve is still sensed as energized after the inducer has been off for 5 seconds, the control re-energizes the inducer to attempt to vent the unburned gas. In either case, the control enters a hard lockout flashing "9" on the LED. If the pilot or main valve becomes Un-Welded the inducer will de-energize, but the control will remain in a hard lockout and not respond to any thermostat demands.

The only way to recover from a hard lockout is to remove and then reapply 24VAC power to the control board.

Flame Sense Circuit Failure

If the control detects an internal hardware failure in the flame sense circuit, it shuts off all outputs and enters a hard lockout flashing "10" on the LED. The control will not respond to thermostat demands during a hard lockout.

The only way to recover from a hard lockout is to remove and then reapply 24VAC power to the control. If problem persists after removal and reapplication of 24VAC power, the board may need to be replaced.

Safety Controls

The control circuit includes the following safety controls:

1. **Limit Switch (LS)** - This control is located inside the heat exchanger compartment and is set to open at the temperature indicated in the Temperature Controls Table of the unit wiring diagram. It resets automatically. The limit switch operates when a high temperature condition caused by inadequate supply air flow occurs, thus shutting down the ignition control and closing the main gas valve and energizing the blower.
 2. **Pressure Switch (PS)** - If the draft motor should fail, the pressure switch prevents the ignition controls and gas valves from being energized.
 3. **Flame Sensor** - The flame sensor and controls are located per Proper Flame Adjustment Figure 18. If an ignition control fails to detect a signal from the flame sensor indicating the pilot flame is properly ignited, then the main gas valve will not open.
 4. **Rollout Switch (RS)** - This switch is located in the burner vestibule. In the event of a sustained main burner flame rollout, it shuts off the ignition control and closes the main gas valve.
- NOTE:** The manual reset **Rollout Switch (RS)** must be reset before allowing furnace operation.
5. **Auxiliary Limit Switch (ALS)** - This control is located inside the heat exchanger compartment and is set to open at 160°F. It is a manual reset switch. If ALS trips, then the primary limit (LS) has not functioned correctly. Replace the primary limit LS.

Table 20: Ignition Control Board Flash Codes

Flash Code	Description
Heart Beat	Normal Operation
2 Flashes	Pressure switch open with inducer on
3 Flashes	Pressure switch closed with inducer off
4 Flashes	Not Used
5 Flashes	Lockout from too many flame losses
6 Flashes	High temperature switch open
7 Flashes	Rollout switch open
8 Flashes	Flame present with gas off
9 Flashes	Gas valve stuck OFF or ON
10 Flashes	Flame sense circuit failure

Cooling Sequence Of Operations

When the thermostat calls for first-stage cooling, the thermostat terminals G and Y energize, signaling the compressor, indoor blower and outdoor fan to operate. The

indoor blower will operate according to the fan delay profile selected using Table 19.

When the thermostat is satisfied, terminals G and Y are de-energized, thus stopping operation of the compressor and outdoor fan. The indoor blower will remain on according to the fan delay profile selected using Table 19.

Safety Controls

The control circuit includes the following safety controls:

1. **High Pressure Switch (HP)**- This switch protects against excessive discharge pressures due to a blocked condenser coil or a condenser motor failure (opens at 625 ± 25 psig and resets at 500 ± 25 psig).
2. **Low Pressure Switch (LP)**- This switch protects against loss of refrigerant charge (opens at 7 ± 3 psig and resets at 22 ± 5 psig).

The above pressure switches are specifically designed to operate with R-410A systems. R-22 pressure switches **must not** be used as replacements for the R-410A pressure switches.

WARNING

The ability to properly perform maintenance on this equipment requires certain expertise, mechanical skills, tools and equipment. If you do not possess these, do not attempt to perform any maintenance other than those procedures recommended in this Installation Manual. Failure to heed this warning could result in serious injury and possible damage to this equipment.

Circulating Fan

When the thermostat calls for FAN, the thermostat terminal G is energized signaling the circulating fan to run at the heat speed 2 seconds after the G terminal is energized.

If a call for HEAT occurs, the circulating fan continues to run at the heat speed.

If a call for COOL occurs, the circulating fan switches to cool speed according to the fan delay profile selected in Table 19.

When the thermostat ends the call for FAN, the thermostat terminal G is de-energized, de-energizing the circulating fan.

Start-Up

Prestart Check List

Complete the following checks before starting the unit.

3. Check the type of gas being supplied. Be sure that it is the same as listed on the unit nameplate.
4. Make sure that the vent outlet air hood has been properly installed.

Operating Instructions

1. STOP! Read the information on the unit safety label.
2. Set the thermostat to the OFF position.
3. Turn off all electrical power to the unit.
4. DO NOT try to light the burners by hand. This appliance is equipped with an ignition device which automatically lights the burners.
5. Remove the access panel.
6. Turn the gas valve switch to the OFF position.
7. Wait five (5) minutes to clear out any gas. If you then smell gas, STOP! Follow B in the information on the unit safety label. If you don't smell gas, go to the next step.
8. Turn the gas valve switch to the ON position.
9. Replace the control access panel.
10. Turn on all electric power to the unit.
11. Set the thermostat to the desired setting.
12. If the unit will not operate, follow the instructions To Turn Off Gas To Appliance and call your service technician or gas supplier.

To Turn Off Gas To Unit

1. Set the thermostat to the OFF position.
2. Turn off all electric power to the appliance if service is to be performed.
3. Remove the control access panel.
4. Turn the gas valve switch to the OFF position. DO NOT FORCE.
5. Replace the control access panel.

Post Start Check List

After the entire control circuit has been energized and the heating section is operating, make the following checks:

1. Check for gas leaks in the unit piping as well as the supply piping.
2. Check for correct manifold gas pressures. See Checking Gas Input.
3. Check the supply gas pressure. It must be within the limits shown on rating nameplate. Supply pressure should be checked with all gas appliances in the building at full fire. At no time should the standby gas line pressure exceed 13.5", nor the operating pressure drop below 4.5" for natural gas units. If gas pressure is outside these limits, contact the local gas utility for corrective action.

Manifold Gas Pressure Adjustment

Small adjustments to the gas flow may be made by turning the pressure regulator adjusting screw on the automatic gas valve. Refer to Figures 14 and 15.

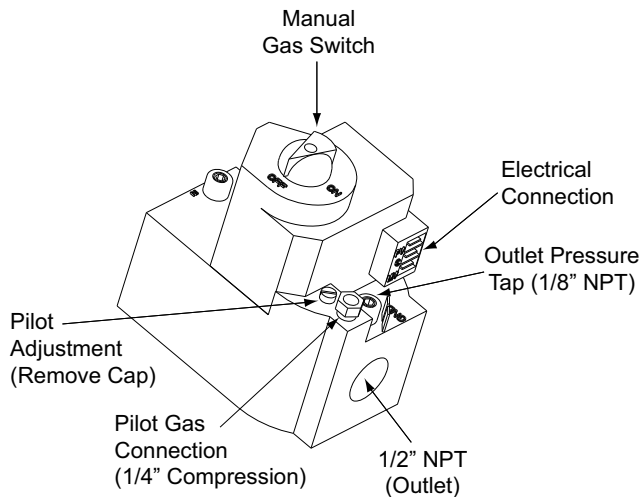

Figure 14: Single Stage Gas Valve Front

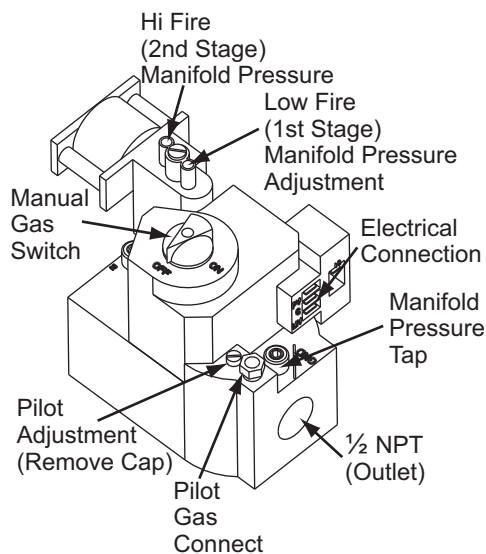

Figure 15: Two Stage Gas Valve Front

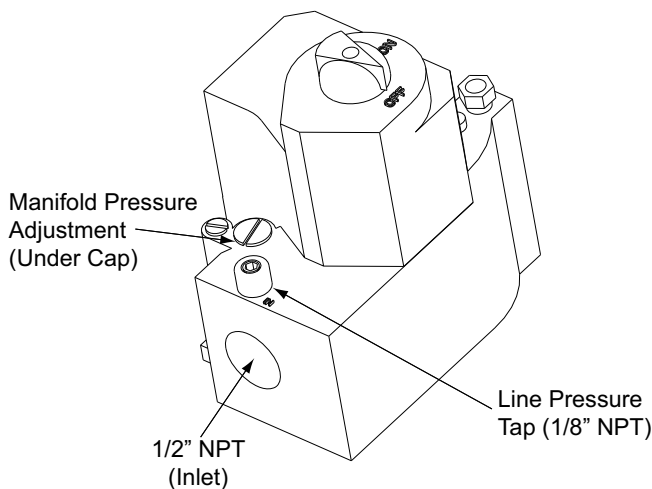

Figure 16: Single Stage Gas Valve Rear

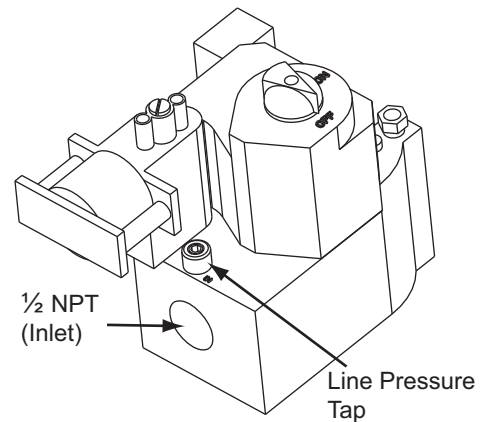

Figure 17: Two Stage Gas Valve Rear

Adjust as follows:

1. Remove the cap from the valve body. See Figures 14 and 15 for location.
2. To decrease the gas pressure, turn the adjusting screw counterclockwise.
3. To increase the gas pressure, turn the adjusting screw clockwise.

NOTE: The correct manifold pressure for natural gas furnaces is 3.5 IWG high heat and 1.5 IWG low heat. The correct manifold pressure for propane (LP) is 10.0 IWG high heat and 4.5 IWG low heat.

Burner Instructions

To check or change the burners, CLOSE THE MAIN MANUAL SHUT-OFF VALVE AND SHUT OFF ALL POWER TO THE UNIT.

1. Remove the two (2) #8 screws holding each burner in place.
2. Remove the burner assembly from the manifold assembly by moving the burner assembly forward, turn at an angle and pull back.
3. Burners are now accessible for service.

Pilot Instruction

To adjust the pilot flame:

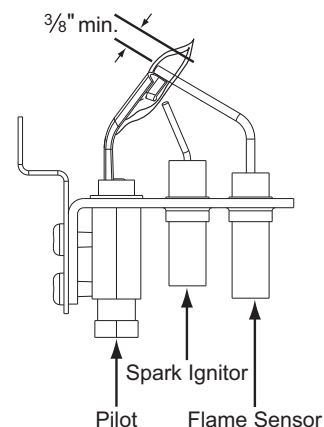

Figure 18: Proper Flame Adjustment

1. Remove the pilot adjustment cover screw.
2. Adjust the pilot adjustment screw to achieve the proper pilot flame.
3. The pilot flame should envelope 3/8" of the end of the flame sensor and not contain any yellow color, see Figure 18.
4. Replace the pilot adjustment cover screw after the pilot flame is set.

To check, adjust or remove the hot surface pilot assembly, CLOSE THE MAIN MANUAL SHUT-OFF VALVE AND SHUT OFF ALL POWER TO THE UNIT.

1. Disconnect the wiring from the control board to the pilot assembly.
2. Remove the two (2) #8 screws holding the pilot assembly in place.
3. Remove the pilot assembly.

Adjustment of Temperature Rise

After about 20 minutes of high heat operation, determine the furnace temperature rise. Take readings of both the return air and the heated air in the ducts about six feet from the furnace where they will not be affected by radiant heat.

The temperature rise (or temperature difference between the return air and the heated air from the furnace) must lie within the range shown on the rating plate and the data in Tables 11 thru 14.

After the temperature rise has been determined, the CFM can be calculated as follows:

$$\text{Degrees F Temp Rise} = \frac{\text{BTUH Output}}{1.08 \times \text{CFM}}$$

OR

$$\text{CFM} = \frac{\text{BTUH Output}}{1.08 \times \text{Degrees F Temp Rise}}$$

Direct Drive Blower

All units have direct drive, constant CFM blower motors.

Checking Gas Heat Input

Natural Gas

1. Turn off all other gas appliances connected to the gas meter.
2. With the furnace turned on, measure the time needed for one revolution of the hand on the smallest dial on the

meter. A typical gas meter usually has a 1/2 or a 1 cubic foot test dial.

3. Using the number of seconds for each revolution and the size of the test dial increment, find the cubic feet of gas consumed per hour from Table 21.

If the actual input is not within 5% of the furnace rating with allowance being made for the permissible range of the regulator setting, replace the orifice spuds with spuds of the proper size.

NOTE: To find the BTU input, multiply the number of cubic feet of gas consumed per hour by the BTU content of the gas in your particular locality. (Contact your gas company for this information since it varies widely from city to city.)

Table 21: Gas Rate Cubic Feet Per Hour¹

Seconds for One Rev.	Size of Test Dial	
	1/2 cu. ft.	1 cu. ft.
10	180	360
12	150	300
14	129	257
16	113	225
18	100	200
20	90	180
22	82	164
24	75	150
26	69	138
28	64	129
30	60	120
32	56	113
34	53	106
36	50	100
38	47	95
40	45	90
42	43	86
44	41	82
46	39	78
48	37	75
50	36	72
52	35	69
54	34	67
56	32	64
58	31	62
60	30	60

1. **EXAMPLE:** By actual measurement, it takes 38 seconds for the hand on the 1-cubic foot dial to make a revolution with just a 100,000 BTUH furnace running. Using this information, locate 38 seconds in the first column of Table 21. Read across to the column headed "1 Cubic Foot," where you will see that 95 cubic feet of gas per hour are consumed by the furnace at that rate. Multiply 95 x 1050 (the BTU rating of the gas obtained from the local gas company). The result is 99,750 BTUH, which is close to the 100,000 BTUH rating of the furnace.

Typical Wiring Diagrams

Typical DNQ024-048 Cooling Unit with Single Stage Gas Heat 208/230-1-60 volt Wiring Diagram

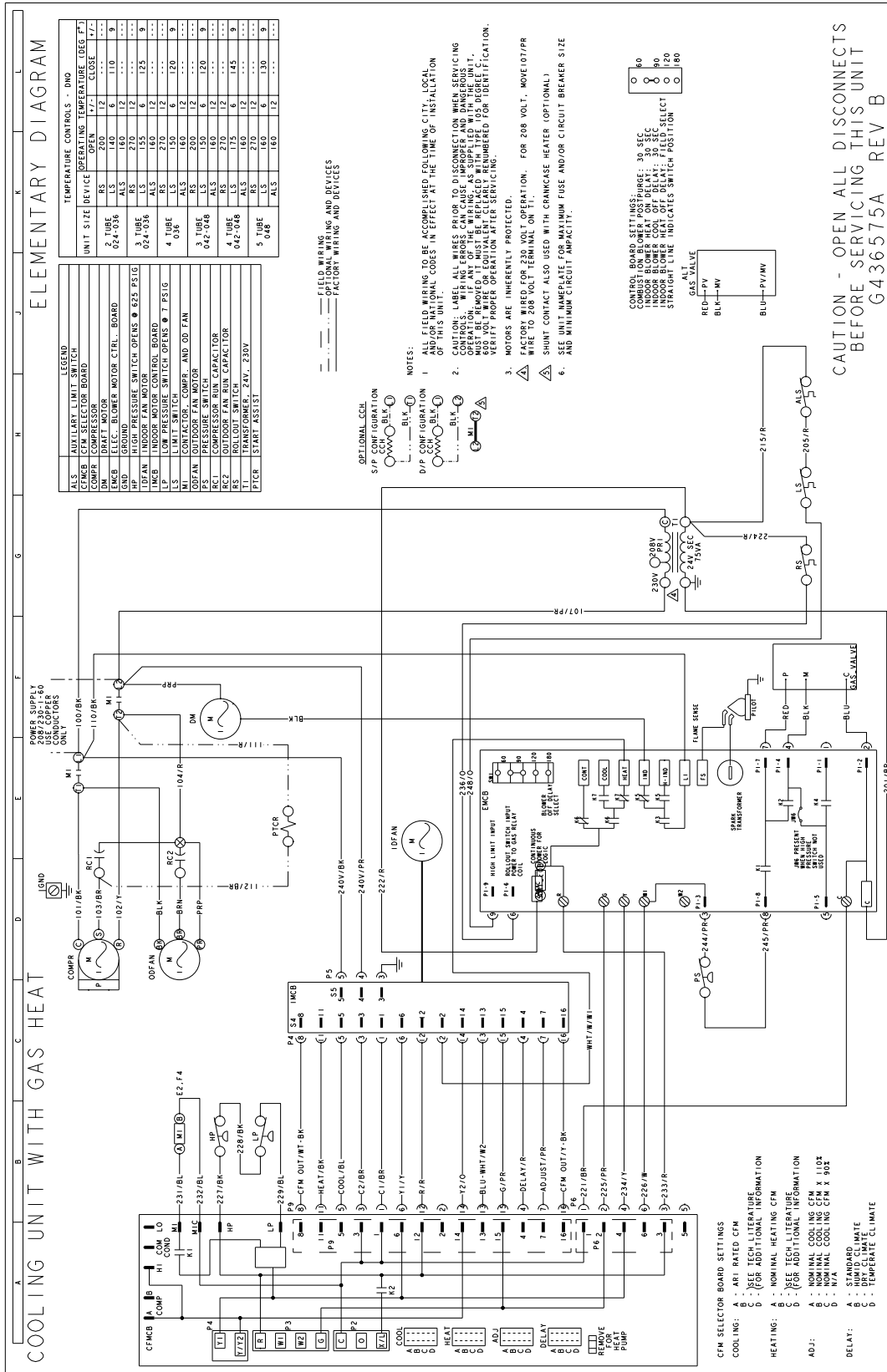

Typical DNQ060 Cooling Unit with Single Stage Gas Heat 208/230-1-60 volt Wiring Diagram

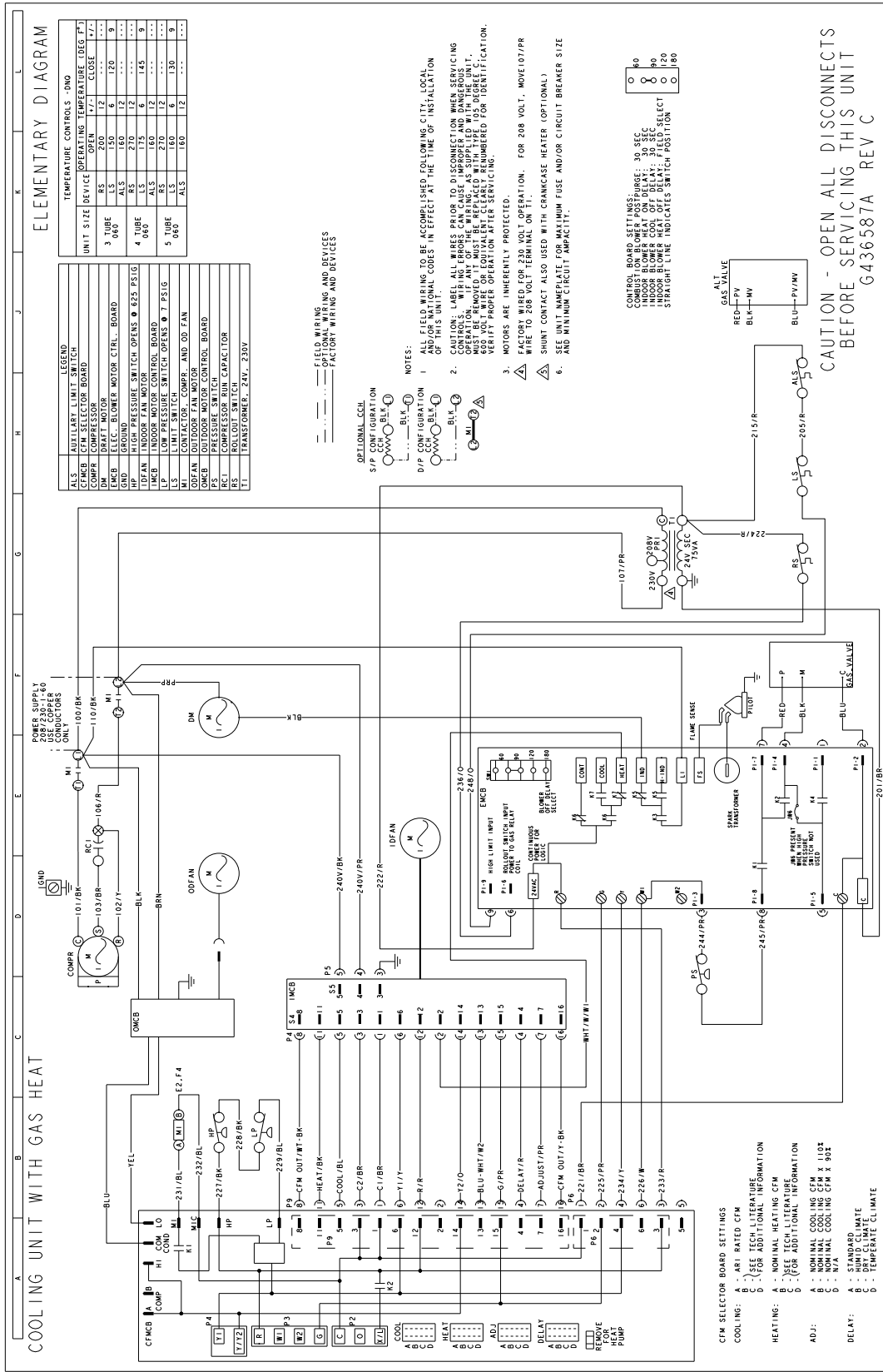

Typical DNQ060 Cooling Unit with Two Stage Gas Heat 208/230-1-60 volt Wiring Diagram

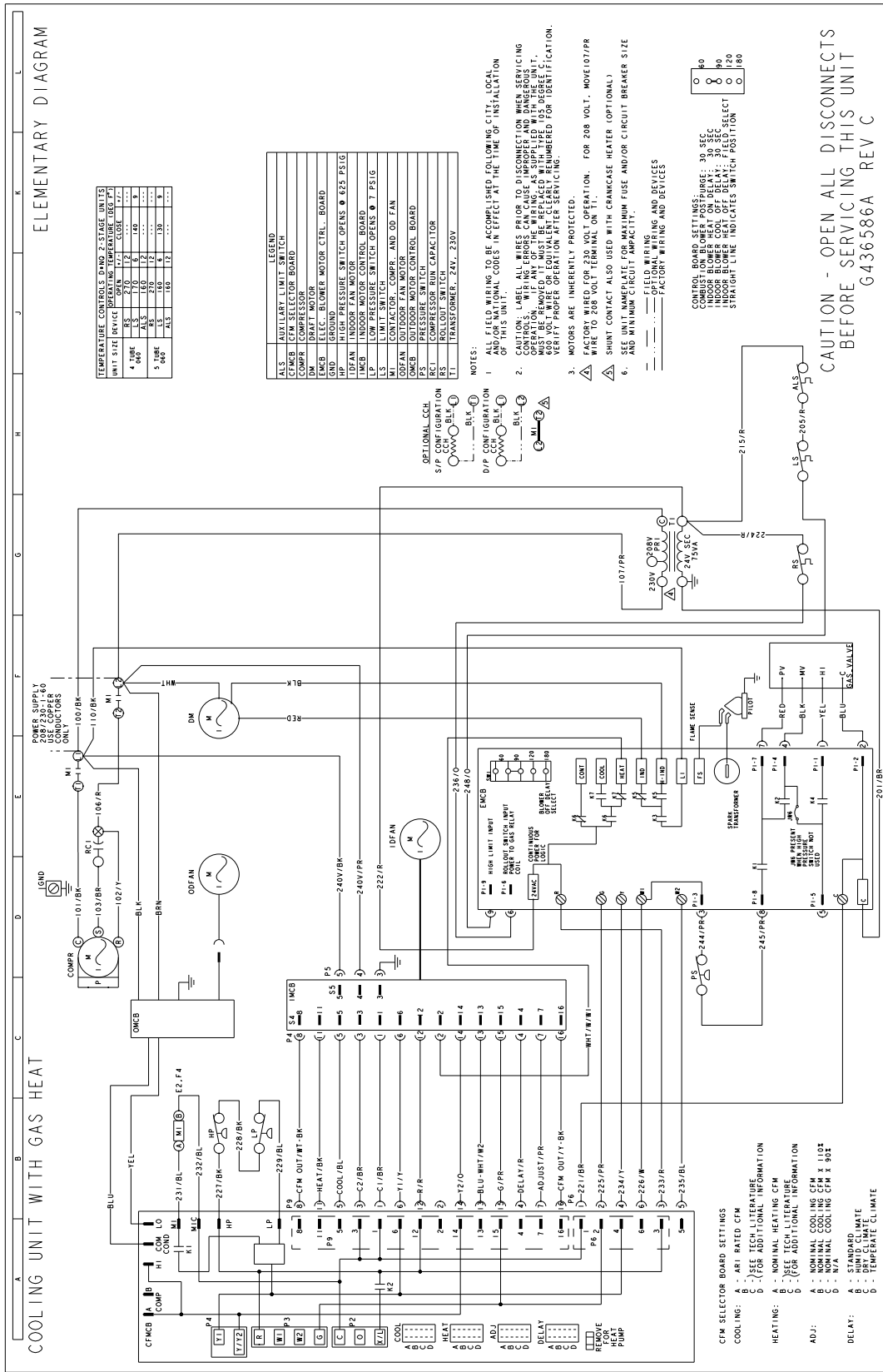

Typical DNQ036-048 Cooling Unit with Single Stage Gas Heat 208/230-3-60 volt Wiring Diagram

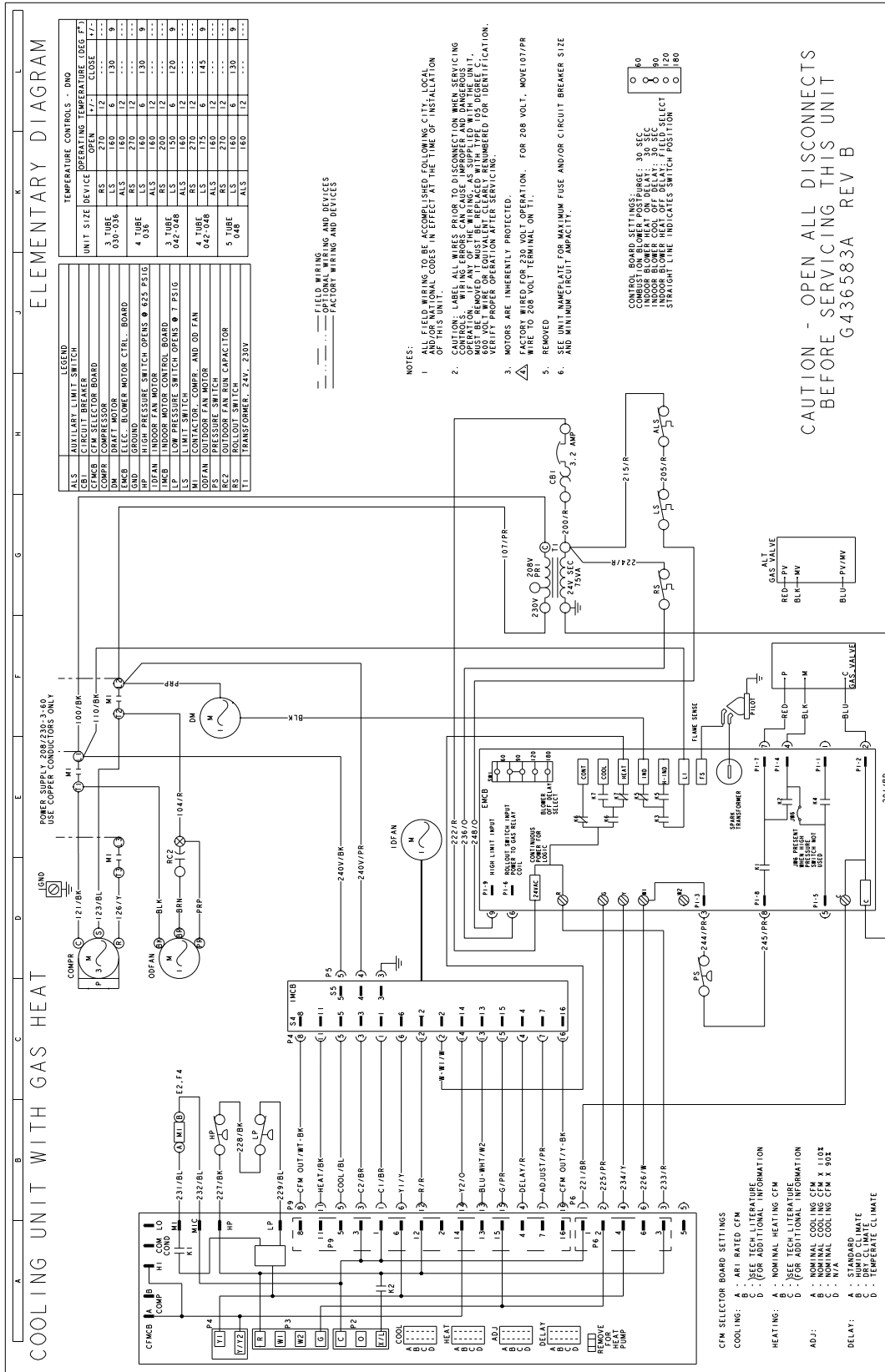

Typical DNQ036-048 Cooling Unit with Two Stage Gas Heat 208/230-3-60 volt Wiring Diagram

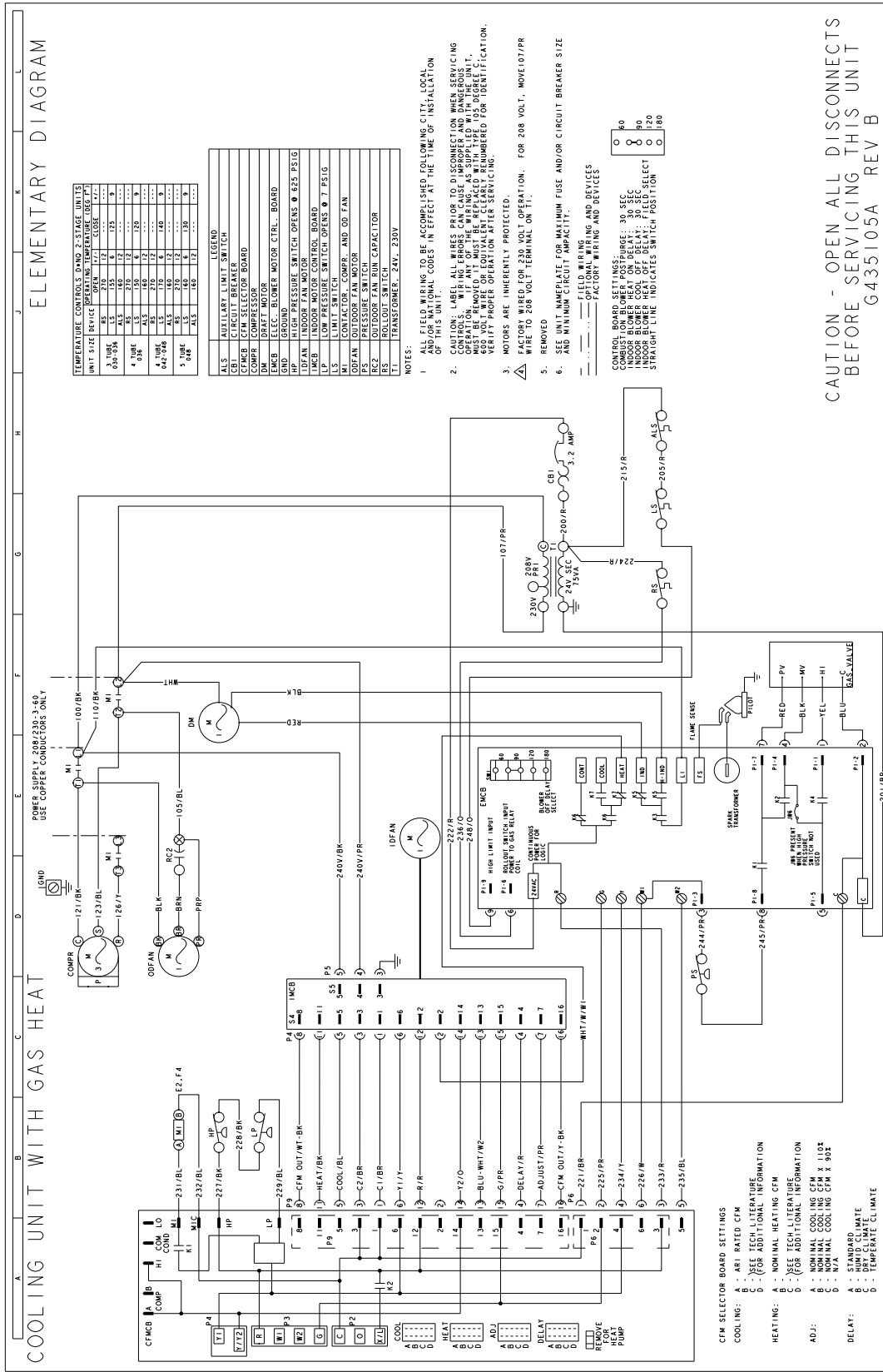

Typical DNQ060 Cooling Unit with Two Stage Gas Heat 208/230-3-60 volt Wiring Diagram

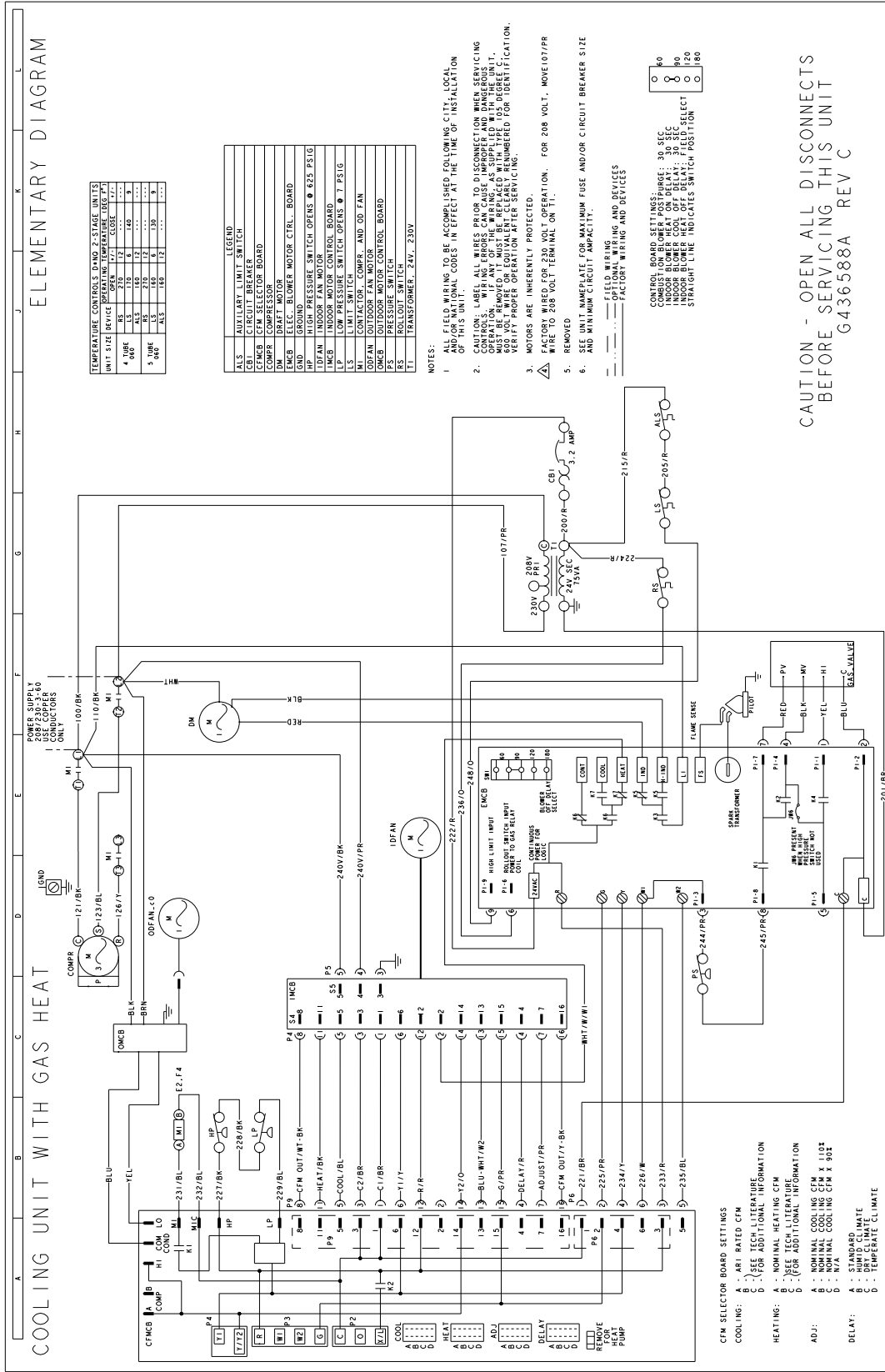

Typical DNQ036-048 Cooling Unit with Two Stage Gas Heat 460-3-60 volt Wiring Diagram

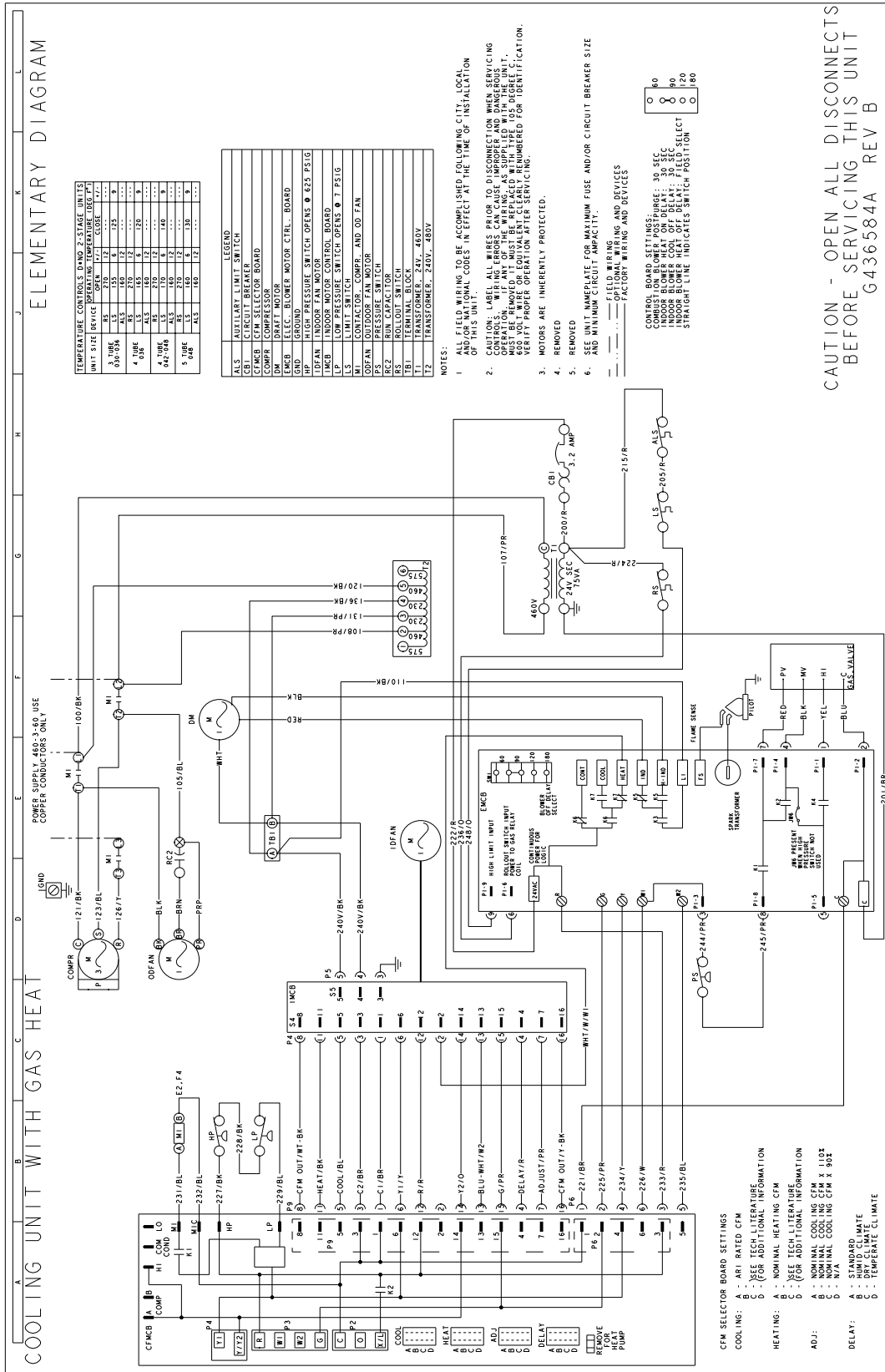

Typical DNQ060 Cooling Unit with Two Stage Gas Heat 460-3-60 volt Wiring Diagram

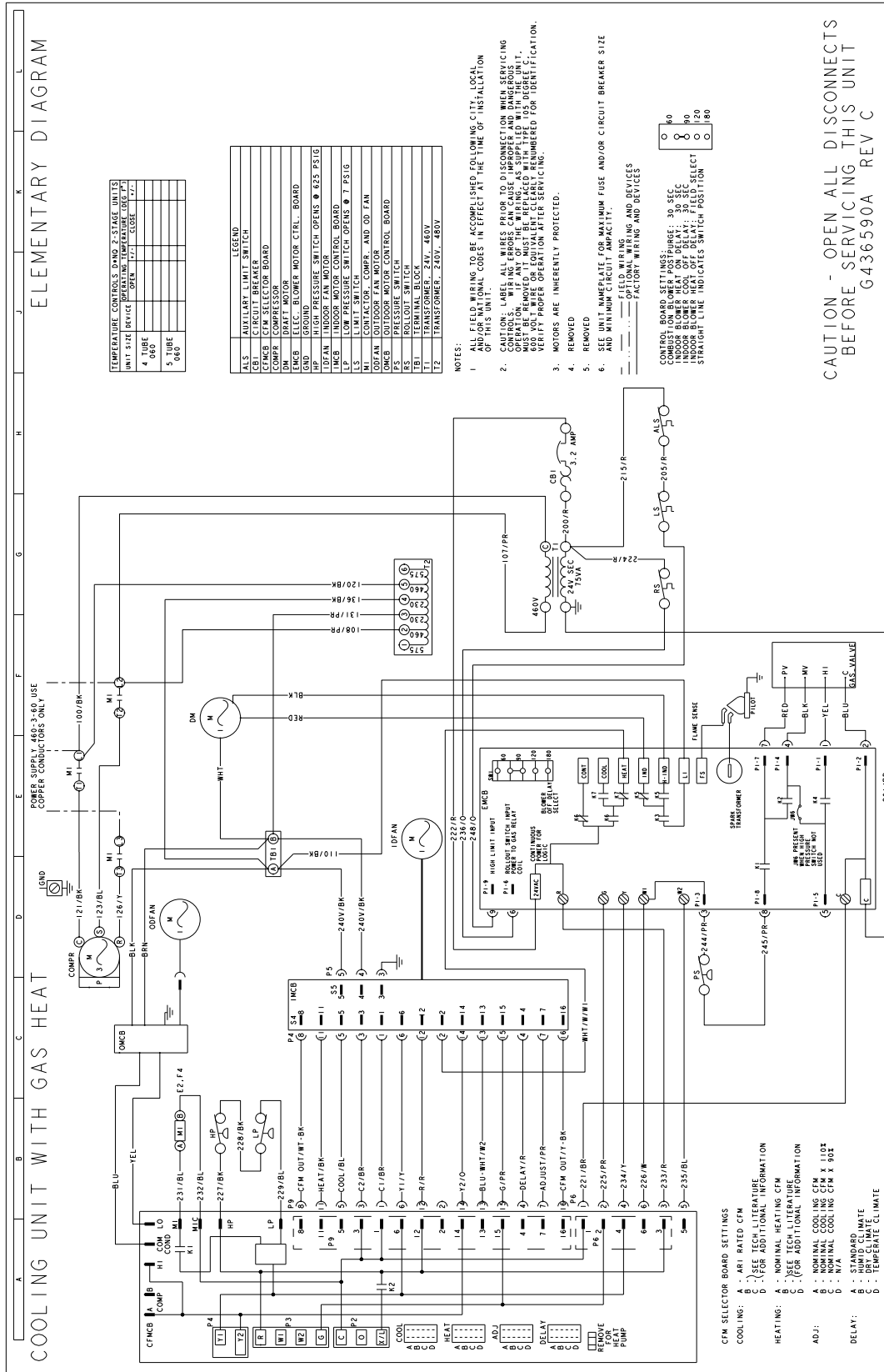

R-410A QUICK REFERENCE GUIDE

Refer to Installation Instructions for specific installation requirements.

- R-410A Refrigerant operates at 50 - 70 percent higher pressures than R-22. Be sure that servicing equipment and replacement components are designed to operate with R-410A.
- R-410A Refrigerant cylinders are rose colored.
- Recovery cylinder service pressure rating must be 400 psig, DOT 4BA400, or DOT BW400.
- Recovery equipment must be rated for R-410A.
- **Do Not** use R-410A service equipment on R-22 systems. All hoses, gages, recovery cylinders, charging cylinders and recovery equipment must be dedicated for use on R-410A systems only.
- Manifold sets must be at least 700 psig high side, and 180 psig low side, with 550 psig retard.
- All hoses must have a service pressure rating of 800 psig.
- Leak detectors must be designed to detect HFC refrigerants.
- Systems must be charged with liquid refrigerant. Use a commercial type metering device in the manifold hose.
- R-410A can only be used with POE type oils.
- POE type oils rapidly absorb moisture from the atmosphere.
- Vacuum pumps will **not** remove moisture from POE type oils.
- **Do not** use liquid line driers with a rated working pressure rating less than 600 psig.
- **Do not** install suction line driers in the liquid line.
- A liquid line drier is required on every unit.
- **Do not** use a R-22 TXV. If a TXV is to be used, it must be a R-410A TXV.
- Never open system to atmosphere when under a vacuum.
- If system must be opened for service, evacuate system then break the vacuum with dry nitrogen and replace all filter driers.

Figure 19: R-410A Quick Reference Guide