

INSTALLATION MANUAL

R-410A
AFFINITY SERIES
DEX024-048
DEY060
2-5 Ton

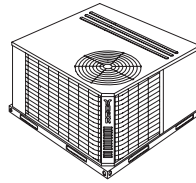

TABLE OF CONTENTS

General	1	Compressors	11
Installation	3	Phasing	12
Limitations	3	Airflow Performance	12
Location	4	Blower Speed Selection	17
Rigging And Handling	4	Operation	18
Ductwork	7	Cooling Sequence Of Operations	18
Roof Curb	7	Heating Sequence Of Operations	18
Filters	7	Maintenance	20
Condensate Drain	7	Normal Maintenance	20
Service Access	8	Troubleshooting	20
Thermostat	8	Typical Wiring Diagrams	21
Power And Control Wiring	8		

LIST OF TABLES

1 Unit Limitations	3	12 Electric Heat Multipliers	15
2 Unit Accessory Weights	5	13 DEX024 Superheat Charging	16
3 Unit Dimensions Front	5	14 DEX030 Superheat Charging	16
4 Unit Clearances	5	15 DEX036 Superheat Charging	16
5 Electrical Data	9	16 DEX042 Superheat Charging	16
6 Physical Data	10	17 DEX048 Superheat Charging	17
7 Side Duct Application	12	18 DEY060 Superheat Charging	17
8 Bottom Duct Application	13	19 Delay Profile	18
9 Additional Static Resistance	14	20 Thermostat Signals (Single Phase Units)	19
10 Electric Heat Minimum Supply Air	15	21 Thermostat Signals (Three Phase Units)	19
11 Indoor Blower Specifications	15		

LIST OF FIGURES

1 Component Location	3	8 Typical Field Control Wiring Diagram 2 Stage Thermostat	9
2 Unit 4 Point Load Weight	4	9 Typical Field Power Wiring Diagram	9
3 Unit Dimensions	5	10 Control Board Speed Tap Location	18
4 Dimensions Front and Bottom	6	11 R-410A Quick Reference Guide	24
5 Dimensions Back and Bottom	6		
6 Roof Curb	7		
7 Typical Field Control Wiring Diagram Single Stage Thermostat	8		

General

YORK® Affinity Models DEX and DEY units are factory assembled cooling units designed for outdoor installation on a roof top or a slab. Field-installed electric heater accessories are available to provide supplemental electric heat combined with electric cooling.

The units are completely assembled on rigid, removable base rails. All piping, refrigerant charge, and electrical wiring is factory installed and tested. The units require only electric power and duct connections at the point of installation.

The electric heaters have nickel-chrome resistance wire elements and utilize single point power connection.

Safety Considerations

This is a safety alert symbol ▲. When you see this symbol on labels or in manuals, be alert to the potential for personal injury.

Understand and pay particular attention the signal words **DANGER**, **WARNING** or **CAUTION**.

DANGER indicates an **imminently** hazardous situation, which, if not avoided, **will result in death or serious injury**.

WARNING indicates a **potentially** hazardous situation, which, if not avoided, **could result in death or serious injury**.

CAUTION indicates a potentially hazardous situation, which, if not avoided **may result in minor or moderate injury**. It is also used to alert against unsafe practices and hazards involving only property damage.

▲ WARNING

Improper installation may create a condition where the operation of the product could cause personal injury or property damage. Improper installation, adjustment, alteration, service or maintenance can cause injury or property damage. Refer to this manual for assistance or for additional information, consult a qualified contractor, installer or service agency.

CAUTION

This product must be installed in strict compliance with the installation instructions and any applicable local, state and national codes including, but not limited to building, electrical, and mechanical codes.

WARNING

Before performing service or maintenance operations on unit, turn off main power switch to unit. Electrical shock could cause personal injury. Improper installation, adjustment, alteration, service or maintenance can cause injury or property damage. Refer to this manual. For assistance or additional information consult a qualified installer or service agency.

CAUTION

This system uses R-410A Refrigerant which operates at higher pressures than R-22. No other refrigerant may be used in this system. Gage sets, hoses, refrigerant containers and recovery systems must be designed to handle R-410A. If you are unsure, consult the equipment manufacturer. Failure to use R-410A compatible servicing equipment may result in property damage or injury.

Due to system pressure, moving parts, and electrical components, installation and servicing of air conditioning equipment can be hazardous. Only qualified, trained service personnel should install, repair, or service this equipment. Untrained personnel can perform basic maintenance functions of cleaning coils and filters and replacing filters.

Observe all precautions in the literature, labels, and tags accompanying the equipment whenever working on air conditioning equipment. Be sure to follow all other applicable safety precautions and codes including.

Nomenclature

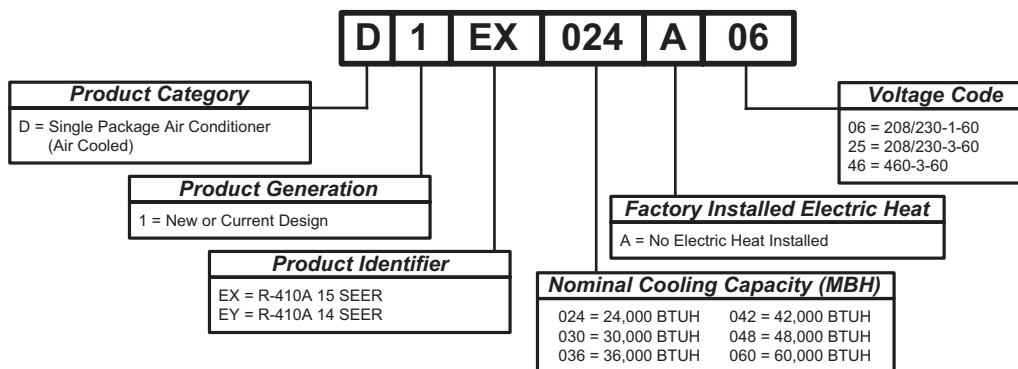

Wear safety glasses and work gloves. Use quenching cloth and have a fire extinguisher available during brazing operations.

Inspection

As soon as a unit is received, it should be inspected for possible damage during transit. If damage is evident, the extent of the damage should be noted on the carrier's freight bill. A separate request for inspection by the carrier's agent should be made in writing.

Reference

Additional information is available in the following reference forms:

- Technical Guide - DEX024-048, DEY060, 294604
- General Installation - DEX024-048, DEY060, 288429
- Electric Heat Accessory - 035-16605-003-E-0705

Renewal Parts

Contact your local York® parts distribution center for authorized replacement parts.

CAUTION

This product must be installed in strict compliance with the enclosed installation instructions and any applicable local, state, and national codes including, but not limited to, building, electrical, and mechanical codes.

WARNING

Improper installation may create a condition where the operation of the product could cause personal injury or property damage.

CAUTION

This system uses R-410A Refrigerant which operates at higher pressures than R-22. No other refrigerant may be used in this system.

Installation

Limitations

These units must be installed in accordance with the following national and local safety codes.

1. National Electrical Code ANSI/NFPA No. 70 or Canadian Electrical Code Part 1, C22.1 (latest editions).
2. Local plumbing and waste water codes and other applicable local codes.

Refer to Table 6 for unit physical data and to Table 5 for electrical data.

If components are to be added to a unit to meet local codes, they are to be installed at the dealer's and/or the customer's expense.

Size of unit for proposed installation should be based on heat loss/heat gain calculations made in accordance with industry recognized procedures identified by the Air Conditioning Contractors of America.

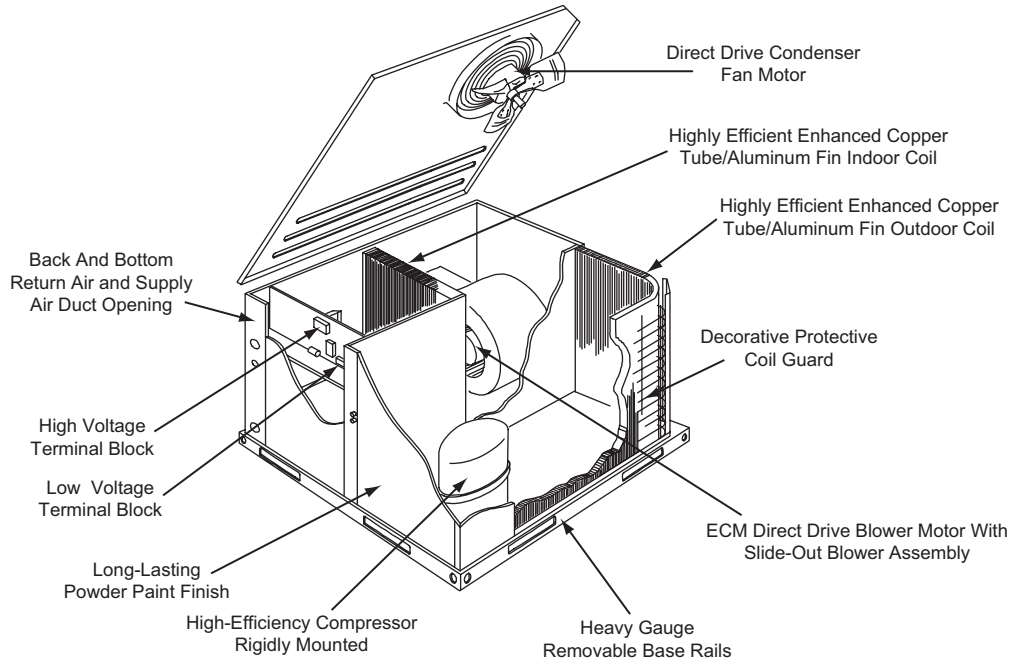

Figure 1: Component Location

Table 1: Unit Limitations

Size (Tons)	Model	Unit Voltage	Unit Limitations		
			Applied Voltage		Outdoor DB Temp
			Min	Max	Max (°F)
024 (2.0)	DEX	208/230-1-60	187	252	115
030 (2.5)	DEX	208/230-1-60	187	252	115
036 (3.0)	DEX	208/230-1-60	187	252	115
		208/230-3-60	187	252	115
		460-3-60	432	504	115
042 (3.5)	DEX	208/230-1-60	187	252	115
		208/230-3-60	187	252	115
		460-3-60	432	504	115
048 (4.0)	DEX	208/230-1-60	187	252	115
		208/230-3-60	187	252	115
		460-3-60	432	504	115
060 (5.0)	DEY	208/230-1-60	187	252	115
		208/230-3-60	187	252	115
		460-3-60	432	504	115

Location

Use the following guidelines to select a suitable location for these units.

1. Unit is designed for outdoor installation only.
2. Condenser must have an unlimited supply of air. Where a choice of location is possible, position unit on either north or east side of building.
3. For ground level installation, a level pad or slab should be used. The thickness and size of the pad or slab used should meet local codes and unit weight. Do not tie the slab to the building foundation.
4. For roof top installation, be sure the structure can support the weight of the unit plus any field installed components. Unit must be installed on a level roof curb or appropriate angle iron frame providing adequate support under the compressor/condenser section.
5. Maintain level tolerance of unit to 1/8" maximum.

WARNING

Do not permit overhanging structures or shrubs to obstruct condenser air discharge outlet, combustion air inlet or vent outlets.

Clearances

All units require certain clearances for proper operation and service. Refer to Table 4 for the clearances required for construction, servicing and proper unit operation.

Rigging And Handling

Exercise care when moving the unit. Do not remove any packaging until the unit is near the place of installation. Rig the unit by attaching chain or cable slings to the lifting holes provided in the base rails. Spreader bars, whose length exceeds the largest dimension across the unit, **MUST** be used across the top of the unit.

CAUTION

If a unit is to be installed on a roof curb other than a York® roof curb, gasketing must be applied to all surfaces that come in contact with the unit underside.

CAUTION

Before lifting, make sure the unit weight is distributed equally on the rigging cables so it will lift evenly.

Units may be moved or lifted with a forklift. Slotted openings in the base rails are provided for this purpose.

CAUTION

All panels must be secured in place when the unit is lifted.
The condenser coils should be protected from rigging cable damage with plywood or other suitable material.

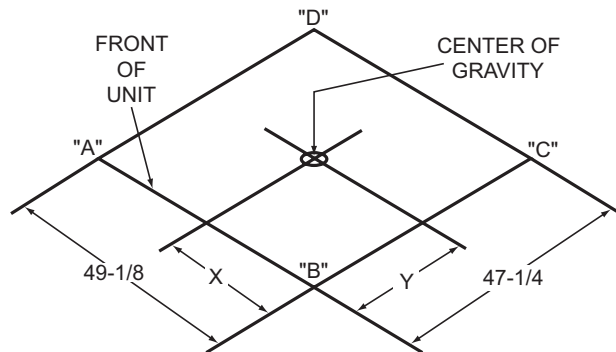

Figure 2: Unit 4 Point Load Weight

Size (Tons)	Model	Weight (lbs.)		Center of Gravity		4 Point Load Location (lbs.)			
		Shipping	Operating	X	Y	A	B	C	D
024 (2.0)	DEX	360	355	22.25	25	96	84	81	93
030 (2.5)	DEX	395	390	22.25	25	106	92	89	102
036 (3.0)	DEX	405	400	22.25	25	109	95	92	105
042 (3.5)	DEX	415	410	22.25	25	111	97	94	108
048 (4.0)	DEX	445	440	22.25	25	120	104	101	115
060 (5.0)	DEY	465	460	22.25	25	125	109	105	121

Table 2: Unit Accessory Weights

Unit Accessory	Model	Weight (lbs.)	
		Shipping	Operating
Add Economizer	All	45	40
Add Electric Heat ¹	All	13	12

1. Weight given is for the maximum heater size available (25 kW).

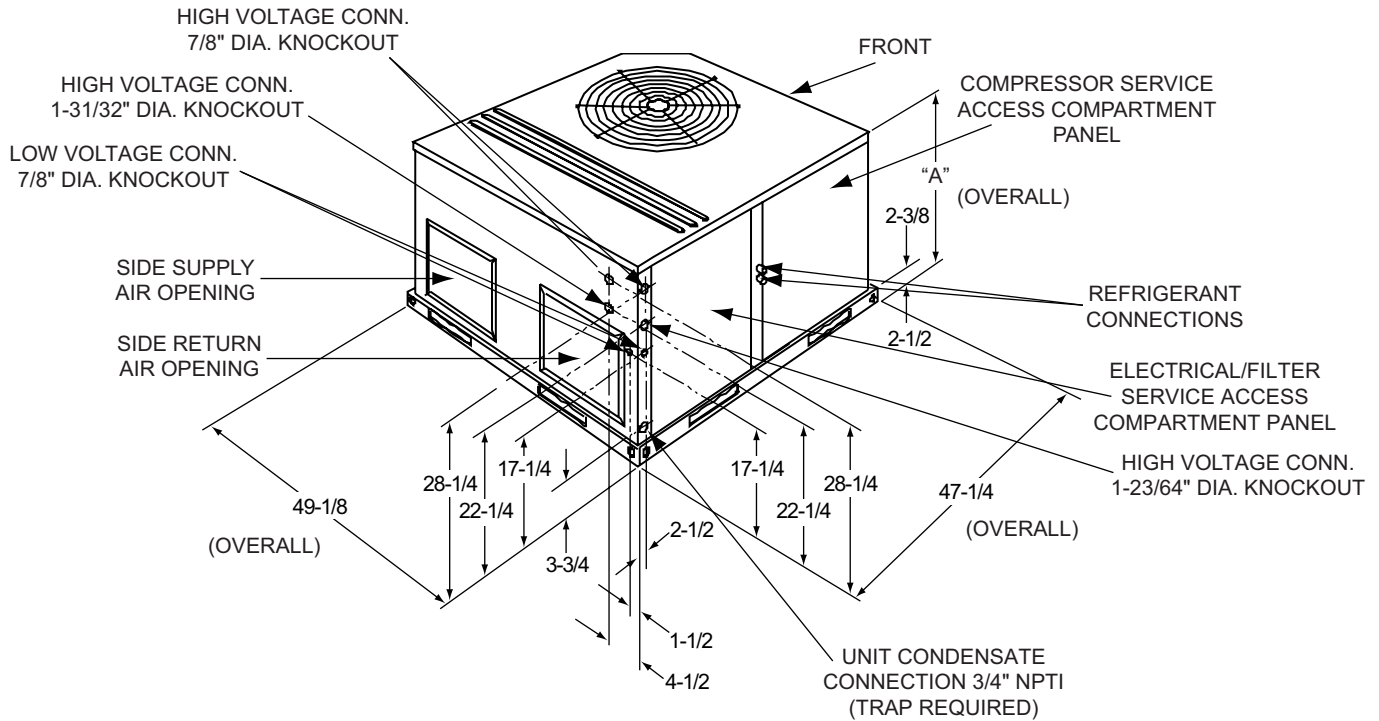

Figure 3: Unit Dimensions

Table 3: Unit Dimensions Front

Unit Size	Dimensions
	"A"
024, 030, 036	33-1/2
042, 048, 060 ¹	41-1/2

1. DEY Models

Table 4: Unit Clearances

Direction	Distance (in.)	Direction	Distance (in.)
Top ¹	36	Right	24
Front	12	Left	24
Rear	0	Bottom ^{2 3}	0

- Units must be installed outdoors. Over hanging structure or shrubs should not obscure condenser air discharge outlet.
- Units may be installed on combustible floors made from wood or class A, B or C roof covering materials.
- Minimum Clearance of 1inch all sides of supply air duct for the first 3 foot of duct for 20 & 25 kW., zero inches there after. For all other heaters, zero inch clearance all sides for entire length of duct.

Note: For units applied with a roof curb, the minimum clearance may be reduced from 1 inch to 1/2 inch between combustible roof curb material and this supply air duct.

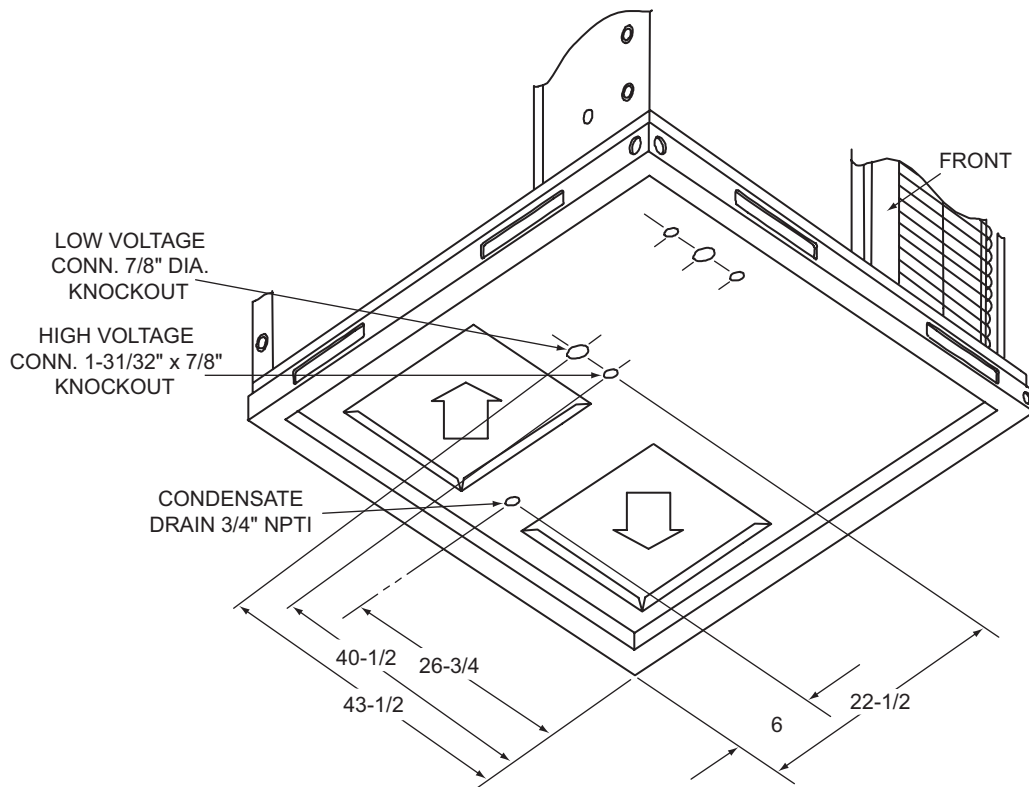

Figure 4: Dimensions Front and Bottom

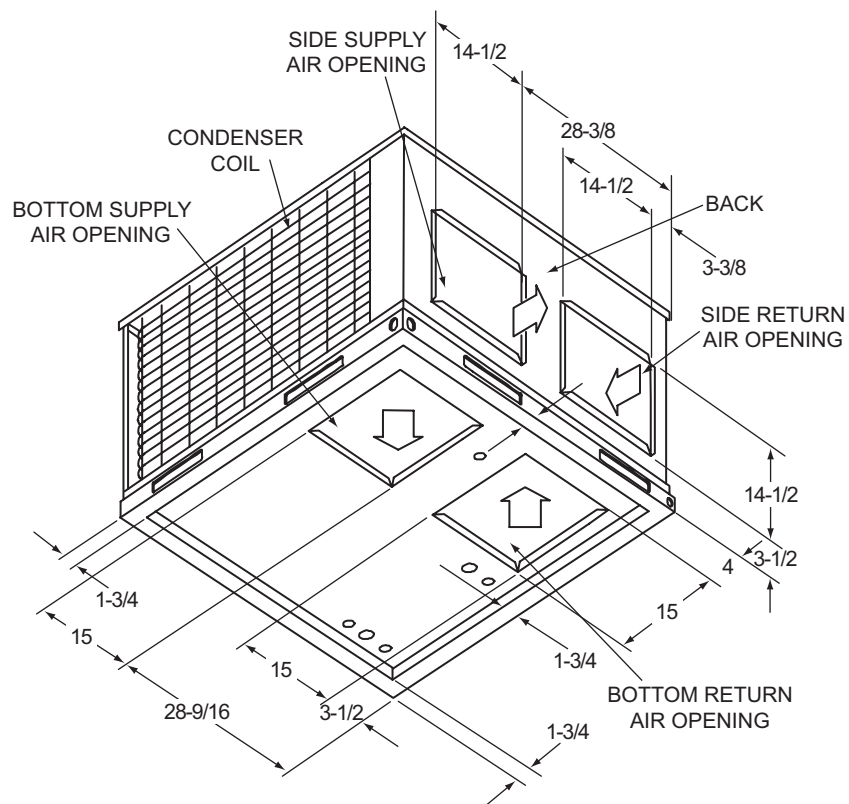

Figure 5: Dimensions Back and Bottom

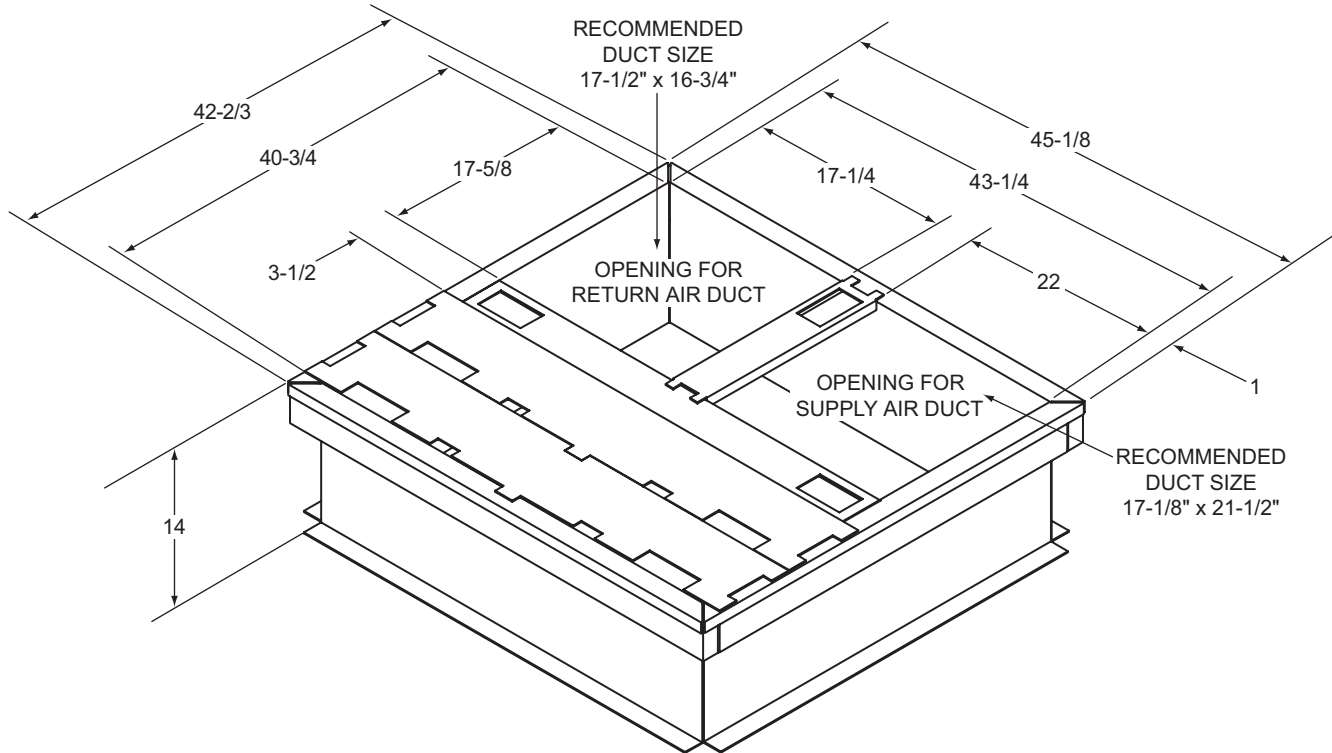

Figure 6: Roof Curb¹

Ductwork

These units are adaptable to downflow use as well as rear supply and return air duct openings. To convert to downflow, use the following steps:

1. Remove the duct covers found in the bottom return and supply air duct openings. There are four (4) screws securing each duct cover (save these screws to use in Step 2).
2. Install the duct covers (removed in step one) to the rear supply and return air duct openings. Secure with the four (4) screws used in step one.
3. Seal duct covers with silicone caulk.

Duct work should be designed and sized according to the methods of the Air Conditioning Contractors of America (ACCA), as set forth in their Manual D.

A closed return duct system shall be used. This shall not preclude use of economizers or ventilation air intake. Flexible joints may be used in the supply and return duct work to minimize the transmission of noise.

CAUTION

When fastening duct work to the side duct flanges on the unit, insert the screws through the duct flanges only. DO NOT insert the screws through the casing. Outdoor duct work must be insulated and waterproofed.

1. 8" Roof Curb also available.

NOTE: Be sure to note supply and return openings.

Refer to Figures 4 and 5 for information concerning rear and bottom supply and return air duct openings.

Roof Curb

On applications when a roof curb is used, the unit must be positioned on the curb so the front of the unit is tight against the curb.

Filters

Single phase units are shipped without a filter or filter racks. It is the responsibility of the installer to secure a filter in the return air ductwork or install a Filter/Frame Kit (1FF0114).

A filter rack and high velocity filters are standard on three phase units.

Filters must always be used and must be kept clean. When filters become dirt laden, insufficient air will be delivered by the blower, decreasing your units efficiency and increasing operating costs and wear-and-tear on the unit and controls.

Filters should be checked monthly; this is especially important since this unit is used for both heating and cooling.

Condensate Drain

A condensate trap is recommended to be installed in the condensate drain. The plumbing must conform to local codes.

Use a sealing compound on male pipe threads. Install the condensate drain line (3/4" NPTF) to spill into an open drain.

Service Access

Access to all serviceable components is provided at the following locations:

- Blower compartment access panel
- Electrical/Filter access panel
- Compressor access panel
- Refrigerant connections

Refer to Figures 1 and 3 for location of these access locations and minimum clearances in Table 4.

CAUTION

This system uses R-410A Refrigerant which operates at higher pressures than R-22. No other refrigerant may be used in this system. Gage sets, hoses, refrigerant containers and recovery systems must be designed to handle R-410A. If you are unsure, consult the equipment manufacturer. Failure to use R-410A compatible servicing equipment may result in property damage or injury.

WARNING

Wear safety glasses and gloves when handling refrigerants. Failure to follow this warning can cause serious personal injury.

Refer to Figure 11 for the R-410A quick reference guide.

Thermostat

The room thermostat should be located on an inside wall approximately 56" above the floor where it will not be subject to drafts, sun exposure or heat from electrical fixtures or appliances. Follow manufacturer's instructions enclosed with the thermostat for general installation procedure. Six color coded insulated wires (minimum #18 AWG) should be used to connect thermostat to unit. See Figures 7 and 8.

Power And Control Wiring

Field wiring to the unit must conform to provisions of the current N.E.C. ANSI/NFPA No. 70 or C.E.C. and/or local ordinances. The unit must be electrically grounded in accordance with local codes or, in their absence, with the N.E.C./C.E.C. Voltage tolerances which must be maintained at the compressor terminals during starting and running conditions are indicated on the unit Rating Plate and Table 5.

The wiring entering the cabinet must be provided with mechanical strain relief.

A fused disconnect switch should be field provided for the unit. If any of the wire supplied with the unit must be replaced, replacement wire must be of the type shown on the wiring diagram.

Electrical line must be sized properly to carry the load. Each unit must be wired with a separate branch circuit fed directly from the meter panel and properly fused.

Refer to Figures 7, 8 and 9 for typical field wiring and to the appropriate unit wiring diagram for control circuit and power wiring information.

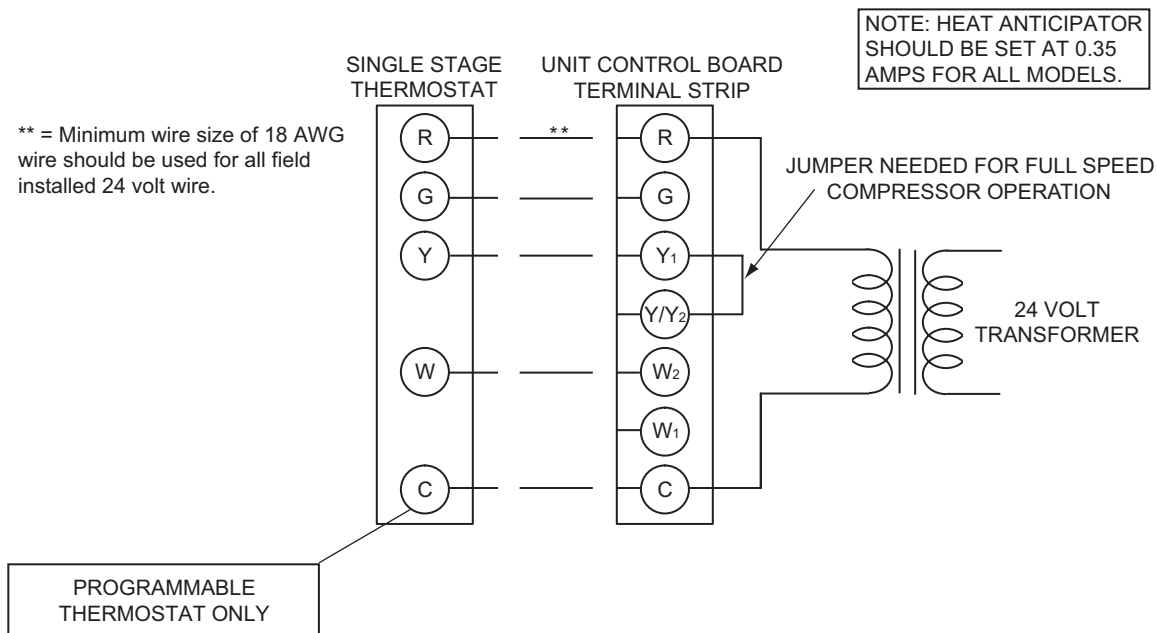

Figure 7: Typical Field Control Wiring Diagram Single Stage Thermostat

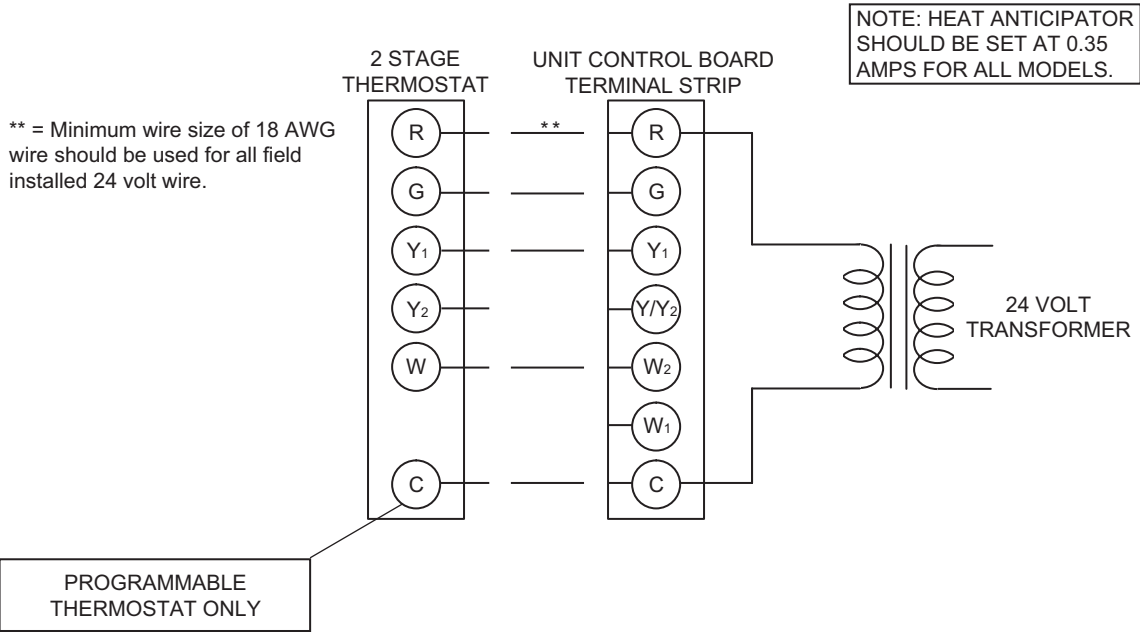

Figure 8: Typical Field Control Wiring Diagram 2 Stage Thermostat

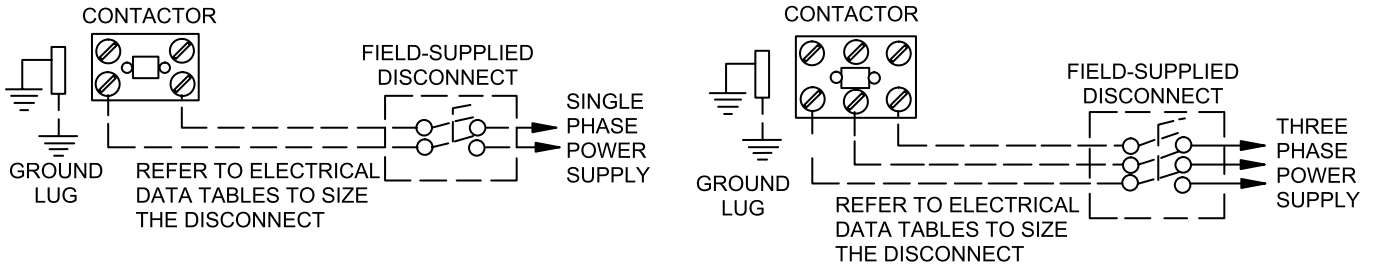

Figure 9: Typical Field Power Wiring Diagram

Table 5: Electrical Data

Size (Tons)	Model	Volt	Compressors (each)			OD Fan Motors (each)	Supply Blower Motor	Electric Heat Option				MCA ¹ (Amps)	Max Fuse ^{2/} Breaker ³ Size (Amps)
			RLA	LRA	MCC			FLA	FLA	Model	kW		
024 (2.0)	DEX	208/230-1-60	10.2	52	16	1.2	4.3	None	-	-	-	18.3	25
								2NH04500506	3.8/5	1	18.1/20.8	27.9 / 31.4	30 / 35
								2NH04500706	5.6/7.5	2	27.1/31.3	39.2 / 44.4	40 / 45
								2NH04501006	7.5/10	2	36.1/41.7	50.5 / 57.5	60 / 60
030 (2.5)	DEX	208/230-1-60	14.1	70	22	1.2	4.3	None	-	-	-	23.1	30
								2NH04500506	3.8/5	1	18.1/20.8	27.9 / 31.4	35 / 35
								2NH04500706	5.6/7.5	2	27.1/31.3	39.2 / 44.4	40 / 45
								2NH04501006	7.5/10	2	36.1/41.7	50.5 / 57.5	60 / 60
								2NH04501506	11.3/15	2	54.2/62.5	73.1 / 83.5	80 / 90
036 (3.0)	DEX	208/230-1-60	16.6	82	26	1.2	4.3	None	-	-	-	26.3	35
								2NH04500506	3.8/5	1	18.1/20.8	27.9 / 31.4	35 / 40
								2NH04500706	5.6/7.5	2	27.1/31.3	39.2 / 44.4	40 / 45
								2NH04501006	7.5/10	2	36.1/41.7	50.5 / 57.5	60 / 60
								2NH04501506	11.3/15	2	54.2/62.5	73.1 / 83.5	80 / 90
		208/230-3-60	11.1	58	17	1.2	4.3	None	-	-	-	19.4	25
								2NH04501025	7.5/10	1	20.8/24.1	31.4 / 35.4	35 / 40
								2NH04501525	11.3/15	1	31.3/36.1	44.5 / 50.5	45 / 60
								None	-	-	-	10.7	15
								2NH04501046	10	1	12	20.4	25
460-3-60	4.5	29	7	0.8	4.3	2NH04501546	15	1	18	27.9	30		

Table 5: Electrical Data (Continued)

Size (Tons)	Model	Volt	Compressors (each)			OD Fan Motors (each)	Supply Blower Motor	Electric Heat Option				MCA ¹ (Amps)	Max Fuse ² / Breaker ³ Size (Amps)
			RLA	LRA	MCC	FLA	FLA	Model	kW	Stages	Amps		
042 (3.5)	DEX	208/230-1-60	16.6	96	26	1.4	6.8	None	-	-	-	29	35
								2NH04500506	3.8/5	1	18.1/20.8	31.1 / 34.5	40 / 45
								2NH04500706	5.6/7.5	2	27.1/31.3	42.4 / 47.6	45 / 50
								2NH04501006	7.5/10	2	36.1/41.7	53.6 / 60.6	60 / 70
		208/230-3-60	13.4	88	21	1.4	6.8	None	-	-	-	25	30
								2NH04501025	7.5/10	1	20.8/24.1	34.6 / 38.6	35 / 40
								2NH04501525	11.3/15	1	31.3/36.1	47.6 / 53.6	50 / 60
								None	-	-	-	15.4	20
		460-3-60	6.1	44	10	0.8	6.8	None	-	-	-	15.4	20
								2NH04501046	10	1	12	23.5	25
								2NH04501546	15	1	18	31.1	35
								None	-	-	-	34.9	45
048 (4.0)	DEX	208/230-1-60	21.1	96	33	1.7	6.8	None	-	-	-	34.9	45
								2NH04501006	7.5/10	2	36.1/41.7	53.6 / 60.6	60 / 70
								2NH04501506	11.3/15	2	54.2/62.5	76.2 / 86.6	80 / 90
								2NH04502006	15/20	2	72.2/83.3	98.8 / 112.7	100 / 125
		208/230-3-60	13.4	88	21	1.7	6.8	None	-	-	-	25.3	35
								2NH04501025	7.5/10	1	20.8/24.1	34.6 / 38.6	35 / 40
								2NH04501525	11.3/15	1	31.3/36.1	47.6 / 53.6	50 / 60
								2NH04502025	15/20	2	41.7/48.1	60.6 / 68.6	70 / 70
		460-3-60	6.4	41	10	1.0	6.8	None	-	-	-	15.9	20
								2NH04501046	10	1	12	23.5	25
								2NH04501546	15	1	18	31.1	35
								2NH04502046	20	2	24.1	38.6	40
060 (5.0)	DEY	208/230-1-60	25.6	118	40	1.7	9.1	None	-	-	-	42.8	60
								2NH04501006	7.5/10	2	36.1/41.7	56.5 / 63.5	60 / 70
								2NH04501506	11.3/15	2	54.2/62.5	79.1 / 89.5	80 / 90
								2NH04502006	15/20	2	72.2/83.3	101.7 / 115.5	110 / 125
		208/230-3-60	17.6	123	28	1.7	9.1	None	-	-	-	32.8	40
								2NH04501025	7.5/10	1	20.8/24.1	37.4 / 41.4	45 / 50
								2NH04501525	11.3/15	1	31.3/36.1	50.5 / 56.5	60 / 60
								2NH04502025	15/20	2	41.7/48.1	63.5 / 71.5	70 / 80
		460-3-60	9.0	62	14	1.0	9.1	None	-	-	-	21.4	30
								2NH04501046	10	1	12	26.4	30
								2NH04501546	15	1	18	33.9	35
								2NH04502046	20	2	24.1	41.4	45
2NH04502546	25	2	30.1	49	50								

1. Minimum Circuit Ampacity.
2. Maximum Over Current Protection per standard UL 1995.
3. Fuse or HACR circuit breaker size installed at factory or field installed.

Table 6: Physical Data

Component	Models					
	DEX024	DEX030	DEX036	DEX042	DEX048	DEY060
Nominal Tonnage	2.0	2.5	3.0	3.5	4.0	5.0
ARI COOLING PERFORMANCE						
Gross Capacity @ ARI A point (Btu)	23.5	29.2	36.8	44.5	50.8	60.4
ARI net capacity (Btu)	23.2	28.6	36.0	43.5	49.0	58.5
EER	12.3	12.3	12.3	12.3	12.3	11.6
SEER	15	15	15	15	15	14.5
Nominal CFM	800	1000	1150	1400	1600	1750
System power (KW)	1.9	2.3	2.9	3.5	4.0	5.0
Refrigerant type	R-410a	R-410a	R-410a	R-410a	R-410a	R-410a
Refrigerant charge (lb-oz)	5-0	8-0	8-0	7-8	10-0	10-8

Table 6: Physical Data (Continued)

Component	Models					
	DEX024	DEX030	DEX036	DEX042	DEX048	DEY060
Nominal Tonnage	2.0	2.5	3.0	3.5	4.0	5.0
DIMENSIONS (inches)						
Length	49 1/8	49 1/8	49 1/8	49 1/8	49 1/8	49 1/8
Width	47 1/4	47 1/4	47 1/4	47 1/4	47 1/4	47 1/4
Height	33 1/2	33 1/2	33 1/2	41 1/2	41 1/2	41 1/2
OPERATING WT. (lbs.)	355	390	400	410	440	460
COMPRESSORS						
Type	Scroll 2-spd	Scroll 2-spd	Scroll 2-spd	Scroll 2-spd	Scroll 2-spd	Scroll 2-spd
Quantity	1	1	1	1	1	1
CONDENSER COIL DATA						
Face area (Sq. Ft.)	11.7	11.7	11.7	16.4	16.4	16.4
Rows	1	2	2	1	2	2
Fins per inch	20	20	20	20	20	20
Tube diameter (in.)	3/8	3/8	3/8	3/8	3/8	3/8
Circuitry Type	Interlaced	Interlaced	Interlaced	Interlaced	Interlaced	Interlaced
EVAPORATOR COIL DATA						
Face area (Sq. Ft.)	4.38	4.38	4.38	5.63	5.63	5.63
Rows	2	2	3	3	3	3
Fins per inch	15	15	15	16	16	16
Tube diameter	3/8	3/8	3/8	3/8	3/8	3/8
Circuitry Type	Interlaced	Interlaced	Interlaced	Interlaced	Interlaced	Interlaced
Refrigerant control	TX Valve	TX Valve	TX Valve	TX Valve	TX Valve	TX Valve
CONDENSER FAN DATA						
Fan diameter (Inch)	22	22	22	22	22	22
Type	Prop.	Prop.	Prop.	Prop.	Prop.	Prop.
Drive type	Direct	Direct	Direct	Direct	Direct	Direct
No. speeds	1	1	1	1	1	1
Number of motors	1	1	1	1	1	1
Motor HP each	1/4	1/4	1/4	1/4	1/3	1/3
RPM	850	850	850	1100	1100	1100
Nominal total CFM	1800	1800	2400	3000	3000	3000
DIRECT DRIVE EVAP FAN DATA						
Quantity	1	1	1	1	1	1
Fan Size (Inch)	10 x 8	10 x 8	10 x 8	11 x 10	11 x 10	11 x 10
Type	Centrifugal	Centrifugal	Centrifugal	Centrifugal	Centrifugal	Centrifugal
No. speeds	2	2	2	2	2	2
Motor HP each	1/2	1/2	1/2	3/4	3/4	1
RPM	Variable	Variable	Variable	Variable	Variable	Variable
Frame size	48	48	48	48	48	48
FILTERS						
Quantity - Size	2 - 22 x 14 x 1	2 - 22 x 14 x 1	2 - 22 x 14 x 1	2 - 22 x 14 x 1	2 - 22 x 14 x 1	2 - 22 x 14 x 1

Compressors

The scroll compressor used in this product is specifically designed to operate with R-410A Refrigerant and cannot be interchanged.

⚠ CAUTION

This system uses R-410A Refrigerant which operates at higher pressures than R-22. No other refrigerant may be used in this system.

The compressor also uses a polyolester (POE oil), Mobil 3MA POE. This oil is extremely hydroscopic, meaning it absorbs water readily. POE oil can absorb 15 times as much water as other oils designed for HCFC and CFC refrigerants. Take all necessary precautions to avoid exposure of the oil to the atmosphere.

⚠ CAUTION

Do not leave the system open to the atmosphere. Unit damage could occur due to moisture being absorbed by the **POE oil** in the system. This type of oil is highly susceptible to moisture absorption

POE (polyolester) compressor lubricants are known to cause long term damage to some synthetic roofing materials.

⚠ CAUTION

Exposure, even if immediately cleaned up, may cause embrittlement (leading to cracking) to occur in one year or more. When performing any service that may risk exposure of compressor oil to the roof, take precautions to protect roofing.

Procedures which risk oil leakage include, but are not limited to, compressor replacement, repairing refrigerant leaks, replacing refrigerant components such as filter drier, pressure switch, metering device or coil.

Units are shipped with compressor mountings which are factory adjusted and ready for operation.

CAUTION

Do not loosen compressor mounting bolts.

Phasing

Three-phase, scroll compressors operate in only one direction. If the scroll is drawing low amperage, has similar suction and discharge pressures, or is producing a high noise level, the scroll is misphased. Change the incoming line connection phasing to obtain the proper rotation.

CAUTION

Scroll compressors require proper rotation to operate properly. Failure to check and correct rotation may result in property damage.

Airflow Performance

Table 7: Side Duct Application

Size (Tons)	Model	Mode	Thermostat Input	Speed Tap	CFM	External Static Pressure (Inch Water Gauge)											
						0.2	0.3	0.4	0.5	0.6	0.7	0.8	0.9	1.0			
						Watts	Watts	Watts	Watts	Watts	Watts	Watts	Watts	Watts			
024 (2.0)	DEX	Cool	Low	Y1	COOL-A	600	57	74	91	108	126	143	161	179	197		
				Y1	COOL-B	450	39	54	69	84	100	117	134	152	171		
				Y1	COOL-C	525	47	63	79	95	112	129	146	164	182		
				Y1	COOL-D	675	71	88	106	124	142	161	179	198	216		
			High	Y1+Y2	COOL-A	800	99	117	137	156	176	196	217	237	258		
				Y1+Y2	COOL-B	600	57	74	91	108	126	143	161	179	197		
				Y1+Y2	COOL-C	700	76	94	112	130	148	167	186	205	224		
				Y1+Y2	COOL-D	900	126	146	166	187	208	231	253	277	300		
		Heat	W1	HEAT-A	800	99	117	137	156	-	-	-	-	-			
			W1	HEAT-B	720	80	98	116	135	-	-	-	-	-			
			W1	HEAT-C	880	120	140	160	180	-	-	-	-	-			
			W1	HEAT-D	800	99	117	137	156	-	-	-	-	-			
		030 (2.5)	DEX	Cool	Low	Y1	COOL-A	670	61	78	95	113	130	148	166	184	201
						Y1	COOL-B	620	54	70	87	104	121	138	156	173	191
						Y1	COOL-C	720	70	88	106	124	142	160	178	197	215
						Y1	COOL-D	770	81	99	118	136	155	174	193	213	232
High	Y1+Y2				COOL-A	1000	159	179	200	222	246	270	296	323	350		
	Y1+Y2				COOL-B	925	129	148	169	190	211	233	256	280	304		
	Y1+Y2				COOL-C	1075	194	214	236	260	285	312	341	371	403		
	Y1+Y2				COOL-D	1150	233	254	277	302	330	360	392	427	463		
Heat	W1			HEAT-A	1000	159	179	200	222	-	-	-	-	-			
	W1			HEAT-B	900	120	139	159	180	-	-	-	-	-			
	W1			HEAT-C	1100	206	227	249	274	-	-	-	-	-			
	W1			HEAT-D	1000	159	179	200	222	-	-	-	-	-			
036 (3.0)	DEX			Cool	Low	Y1	COOL-A	900	120	139	159	180	201	222	244	267	291
						Y1	COOL-B	750	76	94	113	131	150	168	187	206	225
						Y1	COOL-C	830	97	116	135	155	174	194	215	236	256
						Y1	COOL-D	980	150	170	191	213	236	260	285	311	337
		High	Y1+Y2		COOL-A	1200	261	283	306	333	362	394	429	467	507		
			Y1+Y2		COOL-B	1000	159	179	200	222	246	270	296	323	350		
			Y1+Y2		COOL-C	1100	206	227	249	274	300	328	357	389	422		
			Y1+Y2		COOL-D	1300	325	346	372	401	434	471	511	556	604		
		Heat	W1	HEAT-A	1200	261	283	306	333	-	-	-	-	-			
			W1	HEAT-B	1080	196	217	239	263	-	-	-	-	-			
			W1	HEAT-C	1275	308	330	355	383	-	-	-	-	-			
			W1	HEAT-D	1200	261	283	306	333	-	-	-	-	-			
		042 (3.5)	DEX	Cool	Low	Y1	COOL-A	920	139	166	195	224	255	286	319	352	386
						Y1	COOL-B	790	100	124	149	176	205	235	266	299	333
						Y1	COOL-C	850	117	143	170	198	227	257	289	322	356
						Y1	COOL-D	980	159	188	218	249	281	313	346	379	414
High	Y1+Y2				COOL-A	1400	338	383	426	468	509	549	589	627	664		
	Y1+Y2				COOL-B	1200	245	281	318	354	390	426	462	497	533		
	Y1+Y2				COOL-C	1300	290	330	370	409	447	485	523	560	596		
	Y1+Y2				COOL-D	1500	391	439	486	532	576	618	660	700	739		
Heat	W1			HEAT-A	1225	256	293	330	367	-	-	-	-	-			
	W1			HEAT-B	1100	203	237	270	304	-	-	-	-	-			
	W1			HEAT-C	1350	314	356	397	438	-	-	-	-	-			
	W1			HEAT-D	1225	256	293	330	367	-	-	-	-	-			

Table 7: Side Duct Application (Continued)

Size (Tons)	Model	Mode	Thermostat Input	Speed Tap	CFM	External Static Pressure (Inch Water Gauge)									
						0.2	0.3	0.4	0.5	0.6	0.7	0.8	0.9	1.0	
						Watts	Watts	Watts	Watts	Watts	Watts	Watts	Watts	Watts	Watts
048 (4.0)	DEX	Cool	Low	Y1	COOL-A	1050	184	216	248	280	313	346	380	414	449
				Y1	COOL-B	920	139	166	195	224	255	286	319	352	386
				Y1	COOL-C	980	159	188	218	249	281	313	346	379	414
			Y1	COOL-D	1120	211	245	279	313	348	382	417	452	486	
			High	Y1+Y2	COOL-A	1600	448	500	551	600	647	693	736	779	819
				Y1+Y2	COOL-B	1400	338	383	426	468	509	549	589	627	664
		Y1+Y2		COOL-C	1500	391	439	486	532	576	618	660	700	739	
		Heat	W1	HEAT-A	1600	448	500	551	600	647	-	-	-	-	
				HEAT-B	1440	359	405	449	493	535	-	-	-	-	
				HEAT-C	1760	546	606	663	718	771	-	-	-	-	
			W1	HEAT-D	1600	448	500	551	600	647	-	-	-	-	
060 (5.0)	DEY	Cool	Low	Y1	COOL-A	1170	235	283	328	368	404	435	463	485	505
				Y1	COOL-B	1110	205	258	304	345	381	410	434	451	465
				Y1	COOL-C	1210	255	301	344	384	420	454	483	509	533
			Y1	COOL-D	1270	286	329	371	410	448	483	516	547	576	
			High	Y1+Y2	COOL-A	1750	559	608	658	710	762	815	870	925	981
				Y1+Y2	COOL-B	1650	498	542	588	634	683	732	783	835	888
		Y1+Y2		COOL-C	1800	590	643	696	750	805	860	916	973	1030	
		Heat	W1	COOL-D	1900	654	715	775	836	895	955	1013	1072	-	
				HEAT-A	1900	654	715	775	836	895	-	-	-	-	
				HEAT-B	1975	703	772	839	904	968	-	-	-	-	
			W1	HEAT-C	2150	823	913	999	1079	1154	-	-	-	-	
				HEAT-D	2070	767	847	923	997	1066	-	-	-	-	

Table 8: Bottom Duct Application

Size (Tons)	Model	Mode	Thermostat Input	Speed Tap	CFM	External Static Pressure (Inch Water Gauge)									
						0.2	0.3	0.4	0.5	0.6	0.7	0.8	0.9	1.0	
						Watts	Watts	Watts	Watts	Watts	Watts	Watts	Watts	Watts	Watts
024 (2.0)	DEX	Cool	Low	Y1	COOL-A	600	57	74	91	108	126	143	161	179	197
				Y1	COOL-B	450	39	54	69	84	100	117	134	152	171
				Y1	COOL-C	525	47	63	79	95	112	129	146	164	182
			Y1	COOL-D	675	71	88	106	124	142	161	179	198	216	
			High	Y1+Y2	COOL-A	800	99	117	137	156	176	196	217	237	258
				Y1+Y2	COOL-B	600	57	74	91	108	126	143	161	179	197
		Y1+Y2		COOL-C	700	76	94	112	130	148	167	186	205	224	
		Heat	W1	COOL-D	900	126	146	166	187	208	231	253	277	300	
				HEAT-A	800	99	117	137	156	-	-	-	-	-	
				HEAT-B	720	80	98	116	135	-	-	-	-	-	
			W1	HEAT-C	880	120	140	160	180	-	-	-	-	-	
				HEAT-D	800	99	117	137	156	-	-	-	-	-	
030 (2.5)	DEX	Cool	Low	Y1	COOL-A	670	61	78	95	113	130	148	166	184	201
				Y1	COOL-B	620	54	70	87	104	121	138	156	173	191
				Y1	COOL-C	720	70	88	106	124	142	160	178	197	215
			Y1	COOL-D	770	81	99	118	136	155	174	193	213	232	
			High	Y1+Y2	COOL-A	1000	159	179	200	222	246	270	296	323	350
				Y1+Y2	COOL-B	925	129	148	169	190	211	233	256	280	304
		Y1+Y2		COOL-C	1075	194	214	236	260	285	312	341	371	403	
		Heat	W1	COOL-D	1150	233	254	277	302	330	360	392	427	463	
				HEAT-A	1000	159	179	200	222	-	-	-	-	-	
				HEAT-B	900	120	139	159	180	-	-	-	-	-	
			W1	HEAT-C	1100	206	227	249	274	-	-	-	-	-	
				HEAT-D	1000	159	179	200	222	-	-	-	-	-	
036 (3.0)	DEX	Cool	Low	Y1	COOL-A	900	120	139	159	180	201	222	244	267	291
				Y1	COOL-B	750	76	94	113	131	150	168	187	206	225
				Y1	COOL-C	830	97	116	135	155	174	194	215	236	256
			Y1	COOL-D	980	150	170	191	213	236	260	285	311	337	
			High	Y1+Y2	COOL-A	1200	261	283	306	333	362	394	429	467	507
				Y1+Y2	COOL-B	1000	159	179	200	222	246	270	296	323	350
		Y1+Y2		COOL-C	1100	206	227	249	274	300	328	357	389	422	
		Heat	W1	COOL-D	1300	325	346	372	401	434	471	511	556	604	
				HEAT-A	1200	261	283	306	333	-	-	-	-	-	
				HEAT-B	1080	196	217	239	263	-	-	-	-	-	
			W1	HEAT-C	1275	308	330	355	383	-	-	-	-	-	
				HEAT-D	1200	261	283	306	333	-	-	-	-	-	

Table 8: Bottom Duct Application (Continued)

Size (Tons)	Model	Mode	Thermostat Input	Speed Tap	CFM	External Static Pressure (Inch Water Gauge)									
						0.2	0.3	0.4	0.5	0.6	0.7	0.8	0.9	1.0	
						Watts	Watts	Watts	Watts	Watts	Watts	Watts	Watts	Watts	
042 (3.5)	DEX	Cool	Low	Y1	COOL-A	920	139	166	195	224	255	286	319	352	386
				Y1	COOL-B	790	100	124	149	176	205	235	266	299	333
				Y1	COOL-C	850	117	143	170	198	227	257	289	322	356
			Y1	COOL-D	980	159	188	218	249	281	313	346	379	414	
			High	Y1+Y2	COOL-A	1400	338	383	426	468	509	549	589	627	664
				Y1+Y2	COOL-B	1200	245	281	318	354	390	426	462	497	533
		Y1+Y2		COOL-C	1300	290	330	370	409	447	485	523	560	596	
		Heat	W1	HEAT-A	1225	256	293	330	367	-	-	-	-	-	
				HEAT-B	1100	203	237	270	304	-	-	-	-	-	
				HEAT-C	1350	314	356	397	438	-	-	-	-	-	
				HEAT-D	1225	256	293	330	367	-	-	-	-	-	
		048 (4.0)	DEX	Cool	Low	Y1	COOL-A	1050	184	216	248	280	313	346	380
Y1	COOL-B					920	139	166	195	224	255	286	319	352	386
Y1	COOL-C					980	159	188	218	249	281	313	346	379	414
Y1	COOL-D				1120	211	245	279	313	348	382	417	452	486	
High	Y1+Y2				COOL-A	1600	448	500	551	600	647	693	736	779	819
	Y1+Y2				COOL-B	1400	338	383	426	468	509	549	589	627	664
	Y1+Y2			COOL-C	1500	391	439	486	532	576	618	660	700	739	
Heat	W1			HEAT-A	1600	448	500	551	600	647	-	-	-	-	
				HEAT-B	1440	359	405	449	493	535	-	-	-	-	
				HEAT-C	1760	546	606	663	718	771	-	-	-	-	
				HEAT-D	1600	448	500	551	600	647	-	-	-	-	
060 (5.0)	DEY			Cool	Low	Y1	COOL-A	1170	235	283	328	368	404	435	463
		Y1	COOL-B			1110	205	258	304	345	381	410	434	451	465
		Y1	COOL-C			1210	255	301	344	384	420	454	483	509	533
		Y1	COOL-D		1270	286	329	371	410	448	483	516	547	576	
		High	Y1+Y2		COOL-A	1750	559	608	658	710	762	815	870	925	981
			Y1+Y2		COOL-B	1650	498	542	588	634	683	732	783	835	888
			Y1+Y2	COOL-C	1800	590	643	696	750	805	860	916	973	1030	
		Heat	W1	COOL-D	1900	654	715	775	836	895	955	1013	1072	-	
				HEAT-A	1900	654	715	775	836	895	-	-	-	-	
				HEAT-B	1975	703	772	839	904	968	-	-	-	-	
				HEAT-C	2150	823	913	999	1079	1154	-	-	-	-	
		W1	HEAT-D	2070	767	847	923	997	1066	-	-	-	-		

Table 9: Additional Static Resistance

Size (Tons)	Model	CFM	Wet Indoor Coil	Economizer ¹	Filter/Frame Kit	Electric Heat
024 (2.0)	DEX	500	0.01	0.00	0.01	0.02
		600	0.01	0.00	0.02	0.03
		700	0.01	0.00	0.02	0.03
		800	0.01	0.01	0.02	0.03
		900	0.01	0.01	0.02	0.04
		1000	0.02	0.01	0.02	0.04
		1100	0.03	0.01	0.03	0.05
		1200	0.04	0.02	0.03	0.06
030 (2.5)	DEX	700	0.01	0.00	0.02	0.03
		800	0.01	0.01	0.02	0.03
		900	0.01	0.01	0.02	0.04
		1000	0.02	0.01	0.02	0.04
		1100	0.03	0.01	0.03	0.05
		1200	0.04	0.02	0.03	0.06
036 (3.0)	DEX	1300	0.07	0.03	0.17	-
		700	0.01	0.00	0.02	0.03
		800	0.01	0.01	0.02	0.03
		900	0.01	0.01	0.02	0.04
		1000	0.02	0.01	0.02	0.04
		1100	0.03	0.01	0.03	0.05
		1200	0.04	0.02	0.03	0.06
1300	0.04	0.03	0.03	0.07		
1400	0.04	0.04	0.03	0.08		

Table 9: Additional Static Resistance (Continued)

Size (Tons)	Model	CFM	Wet Indoor Coil	Economizer ¹	Filter/Frame Kit	Electric Heat
042 (3.5)	DEX	1100	0.03	0.01	0.03	0.05
		1200	0.04	0.02	0.03	0.06
		1300	0.04	0.03	0.03	0.07
		1400	0.04	0.04	0.03	0.08
		1500	0.05	0.05	0.04	0.09
		1600	0.06	0.06	0.05	0.10
048 (4.0)	DEX	1100	0.03	0.01	0.03	0.05
		1200	0.04	0.02	0.03	0.06
		1300	0.04	0.03	0.03	0.07
		1400	0.04	0.04	0.03	0.08
		1500	0.04	0.05	0.04	0.09
		1600	0.04	0.06	0.05	0.10
		1700	0.05	0.07	0.05	0.11
		1800	0.05	0.07	0.06	0.11
		1900	0.06	0.08	0.06	0.11
		2000	0.07	0.08	0.07	0.12
060 (5.0)	DEY	1100	0.03	0.01	0.03	0.05
		1200	0.04	0.02	0.03	0.06
		1300	0.04	0.03	0.03	0.07
		1400	0.04	0.04	0.03	0.08
		1500	0.04	0.05	0.04	0.09
		1600	0.04	0.06	0.05	0.10
		1700	0.05	0.07	0.05	0.11
		1800	0.05	0.07	0.06	0.11
		1900	0.06	0.08	0.06	0.11
		2000	0.07	0.08	0.07	0.12

1. The pressure drop through the economizer is greater for 100% outdoor air than for 100% return air. If the resistance of the return air duct is less than 0.25 IWG, the unit will deliver less CFM during full economizer operation.

Table 10: Electric Heat Minimum Supply Air

Size (Tons)	Model	Voltage	Minimum Supply Air (CFM)					
			Heater kW					
			5.0	7.5	10.0	15.0	20.0	25.0
024 (2.0)	DEX	208/230-1-60	630	630	800	-	-	-
030 (2.5)	DEX	208/230-1-60	630	630	800	800	-	-
036 (3.0)	DEX	208/230-1-60	1070	1070	1070	1070	-	-
		208/230-3-60	1070	1070	1070	1070	-	-
		460-3-60	1070	1070	1070	1070	-	-
042 (3.5)	DEX	208/230-1-60	1225	1225	1225	1225	-	-
		208/230-3-60	1225	1225	1225	1225	-	-
		460-3-60	1225	1225	1225	1225	-	-
048 (4.0)	DEX	208/230-1-60	-	-	1200	1430	1430	1430
		208/230-3-60	-	-	1200	1430	1430	1430
		460-3-60	-	-	1200	1430	1430	1430
060 (5.0)	DEY	208/230-1-60	-	-	1615	1615	1955	1955
		208/230-3-60	-	-	1615	1615	1955	1955
		460-3-60	-	-	1615	1615	1955	1955

Table 11: Indoor Blower Specifications

Size (Tons)	Model	Motor				
		HP	RPM	Eff.	SF	Frame
024 (2.0)	DEX	1/2	Variable	0.8	1.0	48
030 (2.5)	DEX	1/2	Variable	0.8	1.0	48
036 (3.0)	DEX	1/2	Variable	0.8	1.0	48
042 (3.5)	DEX	3/4	Variable	0.8	1.0	48
048 (4.0)	DEX	3/4	Variable	0.8	1.0	48
060 (5.0)	DEY	1	Variable	0.8	1.0	48

Table 12: Electric Heat Multipliers

Nominal	Voltage		kW Capacity Multipliers ¹
	Applied		
	208	230	
240	208	0.75	
	230	0.92	
480	460	0.92	

1. Electric heaters are rated at nominal voltage. Use this table to determine the electric heat capacity for heaters applied at lower voltages.

Table 13: DEX024 Superheat Charging

Outdoor Temp (°F)	Superheat at Compressor Suction (°F), Airflow = 800 CFM										
	Indoor Wet Bulb Temp (°F)										
	55	57	59	61	63	65	67	69	71	73	75
65	23.4	24.2	25.0	25.8	26.7	27.5	28.3	28.1	27.9	27.8	27.7
70	20.8	21.6	22.4	23.2	24.0	24.8	25.6	25.7	25.9	25.9	26.0
75	18.3	19.1	19.8	20.6	21.3	22.1	22.8	23.3	23.8	24.1	24.3
80	15.8	16.5	17.2	17.9	18.6	19.3	20.1	20.9	21.8	22.2	22.6
85	13.2	13.9	14.6	15.3	15.9	16.6	17.3	18.5	19.7	20.3	20.9
90	12.9	13.5	14.0	14.6	15.2	15.8	16.4	17.7	19.0	19.7	20.3
95	12.5	13.0	13.5	14.0	14.5	15.0	15.5	16.9	18.3	19.0	19.7
100	10.4	11.0	11.6	12.2	12.8	13.4	14.1	15.8	17.5	18.3	19.2
105	8.3	9.1	9.8	10.5	11.2	11.9	12.6	14.6	16.6	17.6	18.6
110	6.3	7.1	7.9	8.7	9.5	10.3	11.2	13.5	15.8	16.9	18.1
115	-	5.1	6.0	6.9	7.9	8.8	9.7	12.3	14.9	16.2	17.5

Table 14: DEX030 Superheat Charging

Outdoor Temp (°F)	Superheat at Compressor Suction (°F), Airflow = 1000 CFM										
	Indoor Wet Bulb Temp (°F)										
	55	57	59	61	63	65	67	69	71	73	75
65	13.4	13.9	14.4	14.9	15.4	15.9	16.4	17.4	18.3	18.8	19.3
70	13.3	13.8	14.2	14.7	15.2	15.7	16.1	17.1	18.0	18.5	18.9
75	13.2	13.6	14.1	14.5	15.0	15.4	15.9	16.8	17.7	18.1	18.6
80	13.0	13.5	13.9	14.3	14.7	15.2	15.6	16.4	17.3	17.8	18.2
85	12.9	13.3	13.7	14.1	14.5	14.9	15.3	16.1	17.0	17.4	17.8
90	12.6	13.0	13.4	13.7	14.1	14.4	14.8	15.7	16.7	17.2	17.6
95	12.4	12.7	13.0	13.3	13.7	14.0	14.3	15.3	16.4	16.9	17.4
100	12.3	12.6	12.9	13.2	13.5	13.8	14.1	15.1	16.2	16.7	17.2
105	12.2	12.5	12.7	13.0	13.3	13.6	13.9	14.9	16.0	16.5	17.0
110	12.1	12.3	12.6	12.9	13.2	13.4	13.7	14.7	15.8	16.3	16.8
115	11.9	12.2	12.5	12.7	13.0	13.2	13.5	14.5	15.6	16.1	16.6

Table 15: DEX036 Superheat Charging

Outdoor Temp (°F)	Superheat at Compressor Suction (°F), Airflow = 1200 CFM										
	Indoor Wet Bulb Temp (°F)										
	55	57	59	61	63	65	67	69	71	73	75
65	18.2	18.5	18.8	19.1	19.4	19.7	20.0	20.6	21.3	21.6	21.9
70	18.7	18.9	19.1	19.3	19.6	19.8	20.0	20.6	21.1	21.4	21.7
75	19.1	19.3	19.4	19.6	19.7	19.9	20.0	20.5	21.0	21.2	21.4
80	19.6	19.6	19.7	19.8	19.9	19.9	20.0	20.4	20.8	21.0	21.2
85	20.0	20.0	20.0	20.0	20.0	20.0	20.0	20.3	20.6	20.8	21.0
90	20.2	20.3	20.3	20.3	20.3	20.3	20.3	20.7	21.0	21.2	21.4
95	20.5	20.5	20.5	20.5	20.6	20.6	20.6	21.0	21.4	21.6	21.8
100	20.7	20.7	20.7	20.8	20.8	20.8	20.8	21.3	21.7	21.9	22.2
105	20.9	21.0	21.0	21.0	21.0	21.0	21.0	21.5	22.0	22.3	22.5
110	21.2	21.2	21.2	21.2	21.2	21.2	21.2	21.8	22.3	22.6	22.9
115	21.4	21.4	21.4	21.4	21.4	21.4	21.4	22.0	22.6	22.9	23.2

Table 16: DEX042 Superheat Charging

Outdoor Temp (°F)	Superheat at Compressor Suction (°F), Airflow = 1400 CFM										
	Indoor Wet Bulb Temp (°F)										
	55	57	59	61	63	65	67	69	71	73	75
65	11.7	12.7	13.7	14.7	15.7	16.7	17.7	20.0	22.3	23.4	24.5
70	11.1	11.9	12.7	13.5	14.3	15.1	15.9	17.9	19.8	20.8	21.8
75	10.4	11.1	11.7	12.3	12.9	13.5	14.2	15.8	17.4	18.2	19.0
80	9.8	10.2	10.7	11.1	11.5	11.9	12.4	13.7	15.0	15.6	16.2
85	9.2	9.4	9.6	9.9	10.1	10.4	10.6	11.6	12.5	13.0	13.5
90	9.0	9.2	9.4	9.6	9.9	10.1	10.3	11.2	12.1	12.6	13.1
95	8.8	9.0	9.2	9.4	9.6	9.8	10.0	10.9	11.8	12.2	12.6
100	9.4	9.6	9.7	9.9	10.1	10.3	10.5	11.4	12.4	12.9	13.4
105	9.9	10.1	10.3	10.4	10.6	10.7	10.9	12.0	13.1	13.6	14.1
110	10.5	10.7	10.8	10.9	11.1	11.2	11.4	12.5	13.7	14.3	14.9
115	11.1	11.2	11.3	11.4	11.6	11.7	11.8	13.1	14.4	15.0	15.6

Table 17: DEX048 Superheat Charging

Outdoor Temp (°F)	Superheat at Compressor Suction (°F), Airflow = 1600 CFM										
	Indoor Wet Bulb Temp (°F)										
	55	57	59	61	63	65	67	69	71	73	75
65	10.1	10.0	9.9	9.8	9.8	9.7	9.6	9.6	9.7	9.7	9.7
70	9.9	9.8	9.7	9.7	9.6	9.5	9.5	9.5	9.6	9.6	9.6
75	9.7	9.6	9.5	9.5	9.4	9.4	9.3	9.4	9.5	9.5	9.5
80	9.5	9.4	9.4	9.3	9.3	9.2	9.2	9.3	9.4	9.4	9.5
85	9.2	9.2	9.2	9.1	9.1	9.0	9.0	9.1	9.2	9.3	9.4
90	8.8	8.9	8.9	8.9	9.0	9.0	9.1	9.2	9.4	9.5	9.5
95	8.4	8.5	8.6	8.7	8.9	9.0	9.1	9.3	9.5	9.6	9.7
100	8.3	8.4	8.5	8.6	8.7	8.8	9.0	9.2	9.5	9.7	9.8
105	8.3	8.4	8.4	8.5	8.6	8.7	8.8	9.2	9.5	9.7	9.9
110	8.2	8.3	8.4	8.4	8.5	8.6	8.7	9.1	9.5	9.8	10.0
115	8.1	8.2	8.3	8.3	8.4	8.4	8.5	9.0	9.5	9.8	10.1

Table 18: DEY060 Superheat Charging

Outdoor Temp (°F)	Superheat at Compressor Suction (°F), Airflow = 1750 CFM										
	Indoor Wet Bulb Temp (°F)										
	55	57	59	61	63	65	67	69	71	73	75
65	16.6	16.7	16.8	16.9	17.1	17.2	17.3	17.9	18.4	18.7	19.0
70	16.2	16.4	16.5	16.6	16.7	16.8	17.0	17.4	17.9	18.1	18.4
75	15.9	16.0	16.1	16.2	16.4	16.5	16.6	17.0	17.4	17.6	17.7
80	15.5	15.7	15.8	15.9	16.0	16.1	16.3	16.5	16.8	17.0	17.1
85	15.2	15.3	15.4	15.5	15.7	15.8	15.9	16.1	16.3	16.4	16.5
90	14.0	14.2	14.3	14.4	14.5	14.6	14.8	15.3	15.9	16.2	16.5
95	12.9	13.0	13.1	13.2	13.4	13.5	13.6	14.6	15.5	16.0	16.5
100	12.6	12.8	12.9	13.0	13.1	13.2	13.3	14.3	15.2	15.7	16.2
105	12.4	12.5	12.6	12.7	12.8	12.9	13.0	14.0	14.9	15.4	15.9
110	12.2	12.3	12.3	12.4	12.5	12.6	12.7	13.7	14.6	15.1	15.6
115	11.9	12.0	12.1	12.2	12.2	12.3	12.4	13.4	14.3	14.8	15.3

Blower Speed Selection

The variable speed blowers are designed to deliver constant CFM regardless of the external static pressure (ESP) in the ductwork. Therefore, if too many supply registers are closed, a filter becomes clogged, or there is a restriction in the ductwork, the motor will automatically operate at a higher speed to compensate for the higher ESP. This may result in a higher operating sound level.

These units have variable speed motors that automatically adjust to provide constant CFM from 0.2" to 0.6" w.c. static pressure. From 0.6" to 1.0" static pressure, CFM is reduced by 2% per 0.1" increase in static. Operation on duct systems with greater than 1.0" w.c. external static pressure is not recommended.

To Set Cooling CFM:

Refer to Tables 7 and 8 for the possible cooling and heating CFM selections.

Find the recommended system airflow for the unit model.

Set desired cooling airflow by moving the jumper on the "Cool" tap located on the CFM selection board as indicated in Tables 7, 8 and Figure 10.

Airflow may be increased by 10% by moving the "ADJ" jumper to "B". Airflow may be decreased by 10% by moving the "ADJ" jumper to "C".

NOTE: CFM indicator light flashes once for every 100 CFM (i.e., 12 flashes = 1200 CFM).

To Set Delay Profile:

Every unit has multiple cooling "blower off delay" profiles to optimize system performance and efficiency. Refer to Table 19 for the regional climate in your area. Place the "DELAY" jumper tap on the CFM selection board to the appropriate pin setting.

To Set Electric Heat CFM:

The airflow required for Electric Heat may be different than for cooling.

Refer to Table 10 for the minimum required CFM for the electric heater installed. Find the desired airflow in Tables 7 and 8. Set the "Heat" Jumper on the CFM selection board to tap shown.

Fan Only CFM:

When the connection is made from "R" to "G", the fan only mode is activated. In this mode, the blower will deliver 75% of the cooling system CFM. This connection is factory set from the manufacturer and cannot be field adjusted.

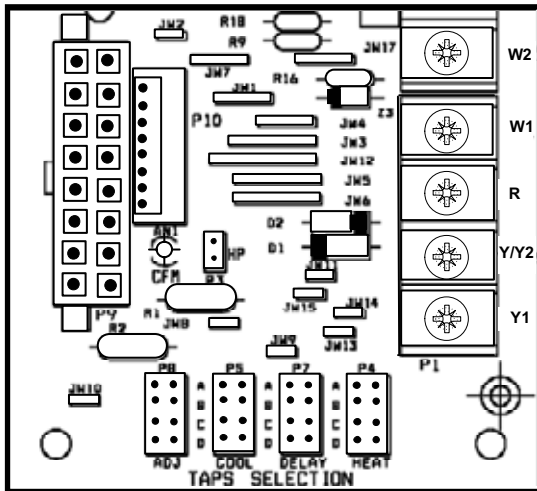

Figure 10: Control Board Speed Tap Location

Table 19: Delay Profile

Delay Tap	Regional Climate Type
Jumper at "A"	Standard Setting
Jumper at "B"	Humid Climate
Jumper at "C"	Dry Climate
Jumper at "D"	Temperate Climate

Operation

Cooling Sequence Of Operations

1. If the fan switch on the thermostat is in the "ON" position, the 24 volts at "G" signals the ECM motor controller to operate the blower at 75% of the rated airflow. If the fan switch on the thermostat is in the "AUTO" position, the blower operates only when there is a call for cooling by the thermostat.
2. If the 2-stage thermostat calls for the first stage of cooling, the 24 volts at "Y1" signals the ECM controller to operate the blower at low speed and closes the contactor coil M1. Power is supplied to the compressor and outdoor fan motor. When the fan switch on the thermostat is in the "AUTO" position, the indoor blower motor is energized at the low-speed cooling airflow.
3. If the 2-stage thermostat calls for the second stage of cooling, the 24 volts at "Y2" signals the ECM controller to

operate the blower at high speed and energizes the compressor solenoid to close the bypass ports so that the compressor operates at full capacity. If the outdoor fan motor has an ECM controller, the 24 volts at "Y2" signals the motor to operate at high speed.

4. When the cooling demand is satisfied, the 24 volt "Y1" and "Y2" signals are removed and the M1 contactor is de-energized. If the fan switch on the thermostat is in the "ON" position, the blower will continue to run at 75% of the rated airflow. If the fan switch is in the "AUTO" position, the blower will continue to run for a short period as determined by the "DELAY" jumper setting on the CFM Selector board.

Heating Sequence Of Operations

1. If the fan switch on the thermostat is in the "ON" position, the 24 volts at "G" signals the ECM motor controller to operate the blower at 75% of the rated airflow. If the fan switch on the thermostat is in the "AUTO" position, the blower operates only when there is a call for heating by the thermostat.
2. For units equipped with supplementary electric heat, 24 volts at "W" sends 24 volts to "W2" on the fan control board. The 24 volt signal energizes all stages of electric heat.
3. When the heating demand is satisfied, the 24 volt "W" signal is removed and the electric heat is de-energized. The M1 contactor is de-energized when the 24 volt "Y" signal is removed. If the fan switch on the thermostat is in the "ON" position, the blower will continue to run at 75% of the rated airflow. If the fan switch is in the "AUTO" position, the blower will continue to run for a short period as determined by the "DELAY" jumper setting on the CFM Selector board.

Please refer to Tables 20 and 21 for more information.

Electric Heat Limit Switch Operation

The limit switch responds to over-temperature conditions in the air duct. Opening the device results in dropping power to the relays. The control logic will also respond by turning off the relays. After four limit cycle trips the unit goes into a 1 hour soft lockout period. If the control "sees" another limit cycle during this period, the unit will go into a hard lockout condition. Once in a hard lockout state, the fan is locked on and the heaters are disabled. Only a power cycle will clear this state.

During the soft lockout period, the fan responds to thermostat input but the heaters are enabled. This is to sense a failed heater relay. The limit cycle count is reset at the start of a heat request. If the limit remains open for period of 80 seconds or more, the control is immediately put into a hard lockout condition. Only a power cycle will clear this state.

Table 20: Thermostat Signals (Single Phase Units)

Signal	State	Board Function
G	ON	BLOWER INSTANT ON AT 75% RATED AIRFLOW
	OFF	BLOWER INSTANT OFF
G & Y1	ON	BLOWER INSTANT ON COMPRESSOR AND OUTDOOR FAN INSTANT ON (AFTER ANTI-SHORT CYCLE DELAY) SYSTEM OPERATES IN FIRST STAGE COOLING
	OFF	COMPRESSOR AND OUTDOOR FAN INSTANT OFF BLOWER OFF DELAY DETERMINED BY "DELAY" JUMPER SETTING
G, Y1 & Y2	ON	BLOWER INSTANT ON COMPRESSOR AND OUTDOOR FAN INSTANT ON (AFTER ANTI-SHORT CYCLE DELAY) SYSTEM OPERATES IN SECOND STAGE COOLING
	OFF	COMPRESSOR AND OUTDOOR FAN INSTANT OFF BLOWER OFF DELAY DETERMINED BY "DELAY" JUMPER SETTING
G & W	ON	BLOWER INSTANT ON HEATER BANK 1 ELEC. HEAT INSTANT ON HEATER BANK 2 ELEC. HEAT 10 SEC. DELAY ON HEATER BANK 3 ELEC. HEAT 20 SEC. DELAY ON
	OFF	HEATER BANK 3 ELEC. HEAT INSTANT OFF HEATER BANK 2 ELEC. HEAT 1/2 SEC. DELAY OFF HEATER BANK 1 ELEC. HEAT 1 SEC. DELAY OFF BLOWER 60 SEC. DELAY OFF
W	ON	BLOWER INSTANT ON HEATER BANK 1 ELEC. HEAT INSTANT ON HEATER BANK 2 ELEC. HEAT 10 SEC. DELAY ON HEATER BANK 3 ELEC. HEAT 20 SEC. DELAY ON
	OFF	HEATER BANK 3 ELEC. HEAT INSTANT OFF HEATER BANK 2 ELEC. HEAT 1/2 SEC. DELAY OFF HEATER BANK 1 ELEC. HEAT 1 SEC. DELAY OFF BLOWER 60 SEC. DELAY OFF

Table 21: Thermostat Signals (Three Phase Units)

Signal	State	Board Function
G	ON	BLOWER INSTANT ON AT 75% RATED AIRFLOW
	OFF	BLOWER INSTANT OFF
G & Y1	ON	BLOWER INSTANT ON COMPRESSOR AND OUTDOOR FAN INSTANT ON (AFTER ANTI-SHORT CYCLE DELAY) SYSTEM OPERATES IN FIRST STAGE COOLING
	OFF	COMPRESSOR AND OUTDOOR FAN INSTANT OFF BLOWER OFF DELAY DETERMINED BY "DELAY" JUMPER SETTING
G, Y1 & Y2	ON	BLOWER INSTANT ON COMPRESSOR AND OUTDOOR FAN INSTANT ON (AFTER ANTI-SHORT CYCLE DELAY) SYSTEM OPERATES IN SECOND STAGE COOLING
G & W	ON	BLOWER INSTANT ON HEATER BANK 1, 2 & 3 ELEC. HEAT INSTANT ON HEATER BANK 4, 5 & 6 ELEC. HEAT 10 SEC. DELAY ON
	OFF	HEATER BANK 4, 5 & 6 ELEC. HEAT INSTANT OFF HEATER BANK 1, 2 & 3 ELEC. HEAT 1/2 SEC. DELAY OFF BLOWER 60 SEC. DELAY OFF
W	ON	BLOWER INSTANT ON HEATER BANK 1, 2 & 3 ELEC. HEAT INSTANT ON HEATER BANK 4, 5 & 6 ELEC. HEAT 10 SEC. DELAY ON
	OFF	HEATER BANK 4, 5 & 6 ELEC. HEAT INSTANT OFF HEATER BANK 1, 2 & 3 ELEC. HEAT 1/2 SEC. DELAY OFF BLOWER 60 SEC. DELAY OFF

Maintenance

Normal Maintenance

WARNING

Prior to any of the following maintenance procedures, shut off all power to the unit, to avoid personal injury.

Periodic maintenance consists of changing or cleaning filters and general cleaning of the outdoor coil.

FILTERS - Inspect once a month. Replace Disposable or clean Permanent Type as necessary. DO NOT replace Permanent Type with Disposable.

MOTORS - Indoor and outdoor fan motors are permanently lubricated and require no maintenance.

OUTDOOR COIL - Dirt should not be allowed to accumulate on the outdoor coil surface or other parts in the air circuit. Cleaning should be as often as necessary to keep the coil clean. Use a brush, vacuum cleaner attachment, or other suitable means. If water is used to clean the coil, be sure that the power to the unit is shut off prior to cleaning.

CAUTION

Exercise care when cleaning the coil so that the coil fins are not damaged.

Do not permit the hot condenser air discharge to be obstructed by overhanging structures or shrubs.

Troubleshooting

WARNING

Troubleshooting of components necessarily requires opening the electrical control box with the power connected to the unit. Use extreme care when working with live circuit! Check the unit nameplate for the correct range before making any connections with line terminals.

CAUTION

The wire number or color and terminal designations referred to may vary. Check the wiring label inside the control box access panel for the correct wiring.

Typical Wiring Diagrams

Typical DEX024-048, DEY060 Cooling Only 208/230-1-60 volt Wiring Diagram

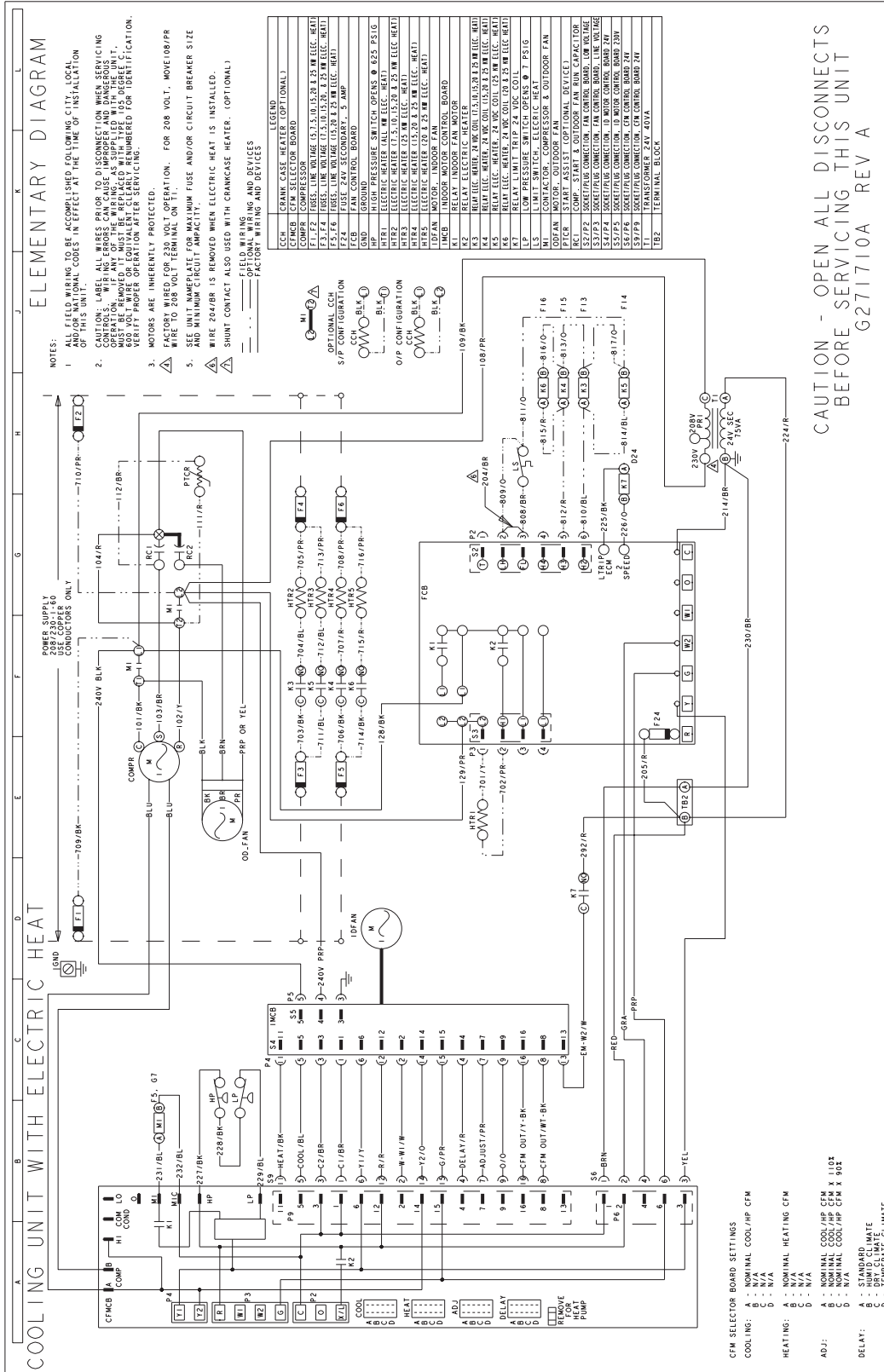

Typical DEX036-048, DEY060 Cooling Only 208/230-3-60 volt Wiring Diagram

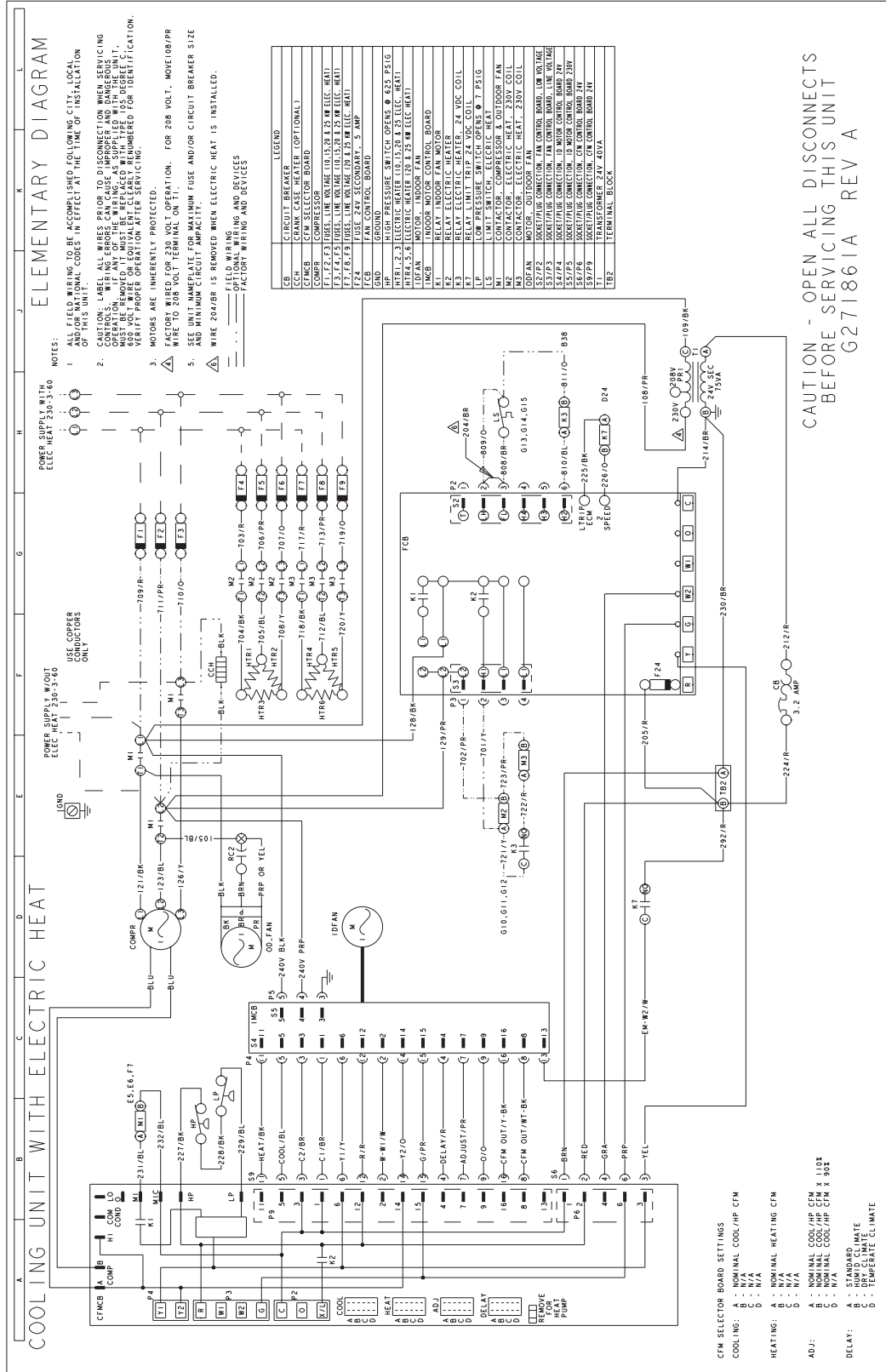

R-410A QUICK REFERENCE GUIDE

Refer to Installation Instructions for specific installation requirements.

- R-410A Refrigerant operates at 50 - 70 percent higher pressures than R-22. Be sure that servicing equipment and replacement components are designed to operate with R-410A.
- R-410A Refrigerant cylinders are rose colored.
- Recovery cylinder service pressure rating must be 400 psig, DOT 4BA400, or DOT BW400.
- Recovery equipment must be rated for R-410A.
- **Do Not** use R-410A service equipment on R-22 systems. All hoses, gages, recovery cylinders, charging cylinders and recovery equipment must be dedicated for use on R-410A systems only.
- Manifold sets must be at least 700 psig high side, and 180 psig low side, with 550 psig retard.
- All hoses must have a service pressure rating of 800 psig.
- Leak detectors must be designed to detect HFC refrigerants.
- Systems must be charged with liquid refrigerant. Use a commercial type metering device in the manifold hose.
- R-410A can only be used with POE type oils.
- POE type oils rapidly absorb moisture from the atmosphere.
- Vacuum pumps will **not** remove moisture from POE type oils.
- **Do not** use liquid line driers with a rated working pressure rating less than 600 psig.
- **Do not** install suction line driers in the liquid line.
- A liquid line drier is required on every unit.
- **Do not** use a R-22 TXV. If a TXV is to be used, it must be a R-410A TXV.
- Never open system to atmosphere when under a vacuum.
- If system must be opened for service, evacuate system then break the vacuum with dry nitrogen and replace all filter driers.

Figure 11: R-410A Quick Reference Guide