



Heating and Air Conditioning

TECHNICAL GUIDE

R-410A

AFFINITY™ SERIES

DEQ MODELS

2 - 5 TON

60 Hertz

Description

These York® Affinity™ packaged air conditioners are designed for outdoor installation. Only utility and duct connections are required at the point of installation.

Field-installed electric heater accessories are available to provide electric heat, if required.



Tested in accordance with:

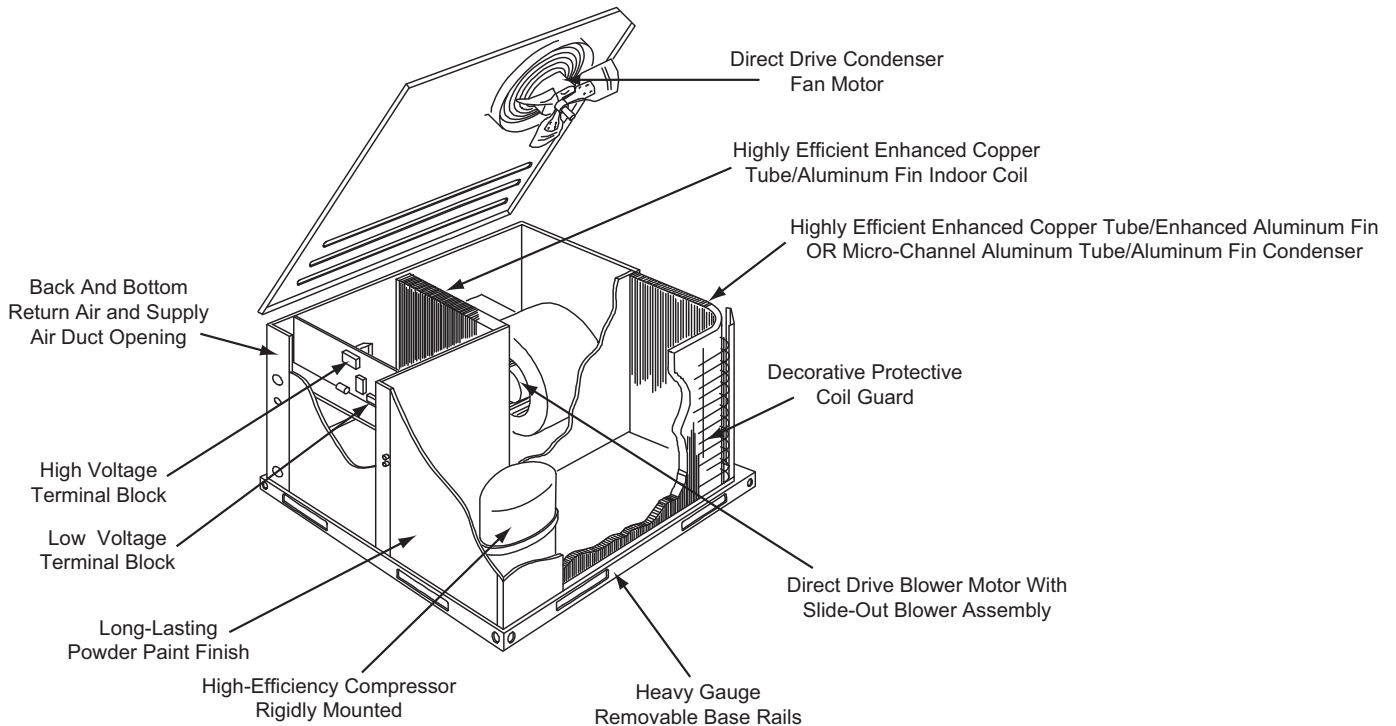

Table of Contents

Description	1
Table of Contents	2
Component Location	2
Nomenclature	3
Features and Benefits	3
Guide Specifications	5
Physical Data	6
Capacity Performance	8
Airflow Performance	20
Sound Performance	23
Electrical Data	24
Typical Wiring Diagrams	25
Weights and Dimensions	31

Component Location

Cooling Only



Nomenclature

Cooling Only

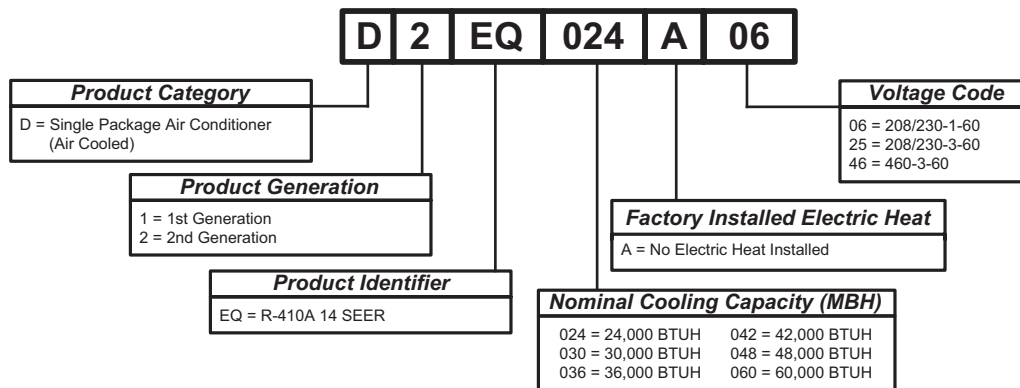

Features and Benefits

Standard Features

- Operating Efficiency** - All air conditioners provide operating efficiencies of 14 SEER. All efficiencies exceed legislated minimum levels.
- On Site Flexibility** - All model sizes share a common, compact design cabinet in a single footprint. The installer has the flexibility of setting one curb and placing the proper tonnage unit on that curb after the internal load has been determined. Field convertible duct connections from side shot to down shot allows the installer to have greater flexibility with less inventory.
- Lower Installation Cost** - Installation time and costs are reduced by easy power and control wiring connections. The small base dimension means less space is required on the ground or roof, plus, the installer can fit this unit between the wheel wells of full size pick-up truck. All units are completely wired, charged with R-410A and tested prior to shipment. Unique test stations using a new state of the art computerized process system are used to insure product quality. Refrigerant charge and component part numbers are verified via computers at assembly. Vital run test statistics such as system pressure, motor currents, air velocity and temperature, unit vibration, and gas system safeties are monitored and recorded by the system to insure unit performance. Equal size, side supply and return duct connections allows easy hook-up of ducts to match low crawl spaces without transition pieces.
- Utility Connections Made Easy** - Electric utility knockouts are provided through the bottom as well as the side of the unit. Utility connections can be made quickly and with a minimum amount of field labor. A field supplied and field installed electrical disconnect switch must be installed.
- Convertible Airflow Design** - The bottom duct openings are covered when they leave the factory ready to be used for a side supply/side return application. If a bottom supply/bottom return application is desired, you simply remove the two panels from the bottom of the unit and place them in the side supply/side return duct openings. No panel cutting is required and no accessory panel is necessary. Convertible airflow design allows maximum field flexibility and minimum inventory.
- Condensate Pan** - A non-corrosive, long-lasting, water-tight pan is positioned below the evaporator coil to collect and drain all condensate. Less collection of stagnate condensate will build-up. The condensate pan conforms to ASHRAE 62-89 standards (Ventilation for Acceptable Indoor Air Quality).
- Condensate Drain** - The heavy duty, 3/4 inch NPTI copper connection is more durable over time. The connection is rigidly mounted to assure proper fit and leak tight seal.
- Durable Finish** - The cabinet is made of pre-painted steel. The pre-treated galvanized steel provides a better paint to steel bond, which resists corrosion and rust creep. Special primer formulas and matted-textured finish insure less fading when exposed to sunlight.
- Full Perimeter Base Rails** - The easily removable base rails provide a solid foundation for the entire unit and protects the unit during shipment. The rails provide fork lift access from all sides, and rigging holes are also provided so that an overhead crane can be used to place the units on a roof. On applications where the unit is placed on a pad, the base will keep the unit off the pad to deter corrosion. On applications where height is limited, the inch high base rails may be removed on location.
- More Attractive Appearance** - A single piece Water Shed top cover containing a top discharge condenser fan arrangement requires less square footage on installation and provides a wider variety of installations. The one piece design adds greater water integrity. Rounded corners with water drip edges add to the attractive appearance. The cabinet panels have a non-fibrous insulation that will not release insulation fibers into conditioned area.
- Top Discharge** - The top discharge condenser fan does not disrupt neighboring areas or dry-out vegetation surrounding the unit. The warm air from the top mounted fan is blown up away from the structure and any landscaping. This allows compact location on multi-unit applications.
- Condenser Coil Grille** - All models utilize a stamped "Louvered" design which provides superior impact protection against smaller objects during transit and after installation.
- Low Operating Sound Level** - The upward air flow carries the normal operating noise up and away from the living area. The rigid top panel effectively isolates any motor sound. Isolator mounted compressor and the

rippled fins of the condenser coil muffle the normal fan motor and compressor operating sounds. The unique formed base pan also aids in sound alterations with its Super-Structure design. This design strategically places embossments in the pan for optimum strength and rigidity.

- **Fan System** - All models operate over a wide range of design conditions with an electrically commutated fan motor. These units easily match all types of applications and provide greater on site flexibility to match comfort requirement. The cooling speed is factory set and can be field adjusted to a second speed. The heating speed is factory set but can be field adjusted. This allows maximum comfort conditions.
- **Simple Control Circuit** - A low voltage printed circuit board contains a diagnostic indicator light and a low voltage terminal strip. An additional set of pin connectors is also provided to simplify the field interface of external controls. Mate-n-lock plug connectors are used. The electrical control box is not located in the compressor compartment. The controls are mounted on a Control-Tilt control panel to allow the access cover to be removed for trouble shooting and maintenance without affecting the normal system operating pressures. All wiring internal to the unit is color/number coded.
- **Protected Compressor** - The compressor is internally protected against high pressure and temperature. This is accomplished by the simultaneous operation of high pressure relief valve and a temperature sensor which protect the compressor if undesirable operating conditions occur.
- **Pressure Switches** - High pressure and low pressure/loss of charge switches standard in all units. When abnormal conditions are sensed through the pressure switches, the unit will lock out preventing any further operation until reset or problem is corrected.
- **Exclusive Coil Design** - Grooved copper tubes and enhanced aluminum fin construction improves heat transfer for maximum efficiency and durability.
- **Self Diagnostic Fan Control Module** - Due to this self diagnostic control, less on site time is required to trouble shoot these units.
- **Low Maintenance** - Long life, permanently lubricated condenser and evaporator fan motor bearings need no annual maintenance adding greater reliability to the unit. Blower assembly can be easily cleaned by the unique Slip-Track slide-out blower assembly.
- **Secured Service Access Ports** - Protected, externally mounted, re-usable service access ports are provided on both the high and low lines for ease of evacuating and charging the system. No final field mounting required.
- **Easy Service Access** - A large, single panel covers the electrical controls to make servicing easy. The blower compartment has an additional large panel with a built-in handle tab. Removing this panel will allow the blower assembly to slide-out for easy removal for maintenance and ease of trouble shooting.
- **Replacement Parts** - The installer requires no special training to replace any of the components of these units and does not need to maintain an inventory of unique parts.
- **System Integration** - Each unit has the internal ability to integrate an electronic air cleaner or humidifier to work in conjunction with the base unit.

Field Installed Accessories

- **Economizer Down Discharge/Supply Kit** - Modulating integrated economizer provides simultaneous operation between the mechanical cooling and economizer operation. Independent blade design insures proper control and less than 1% leak rate. Includes hood and mesh bird screen filter integrated into the hood, dry bulb sensor and relief damper. Separate field accessories of single enthalpy and dual enthalpy are also available. A built-in barometric relief of 25% is provided.
- **Single Enthalpy Sensor** - Sensor replaces dry bulb sensor standard in economizer kit. Provides improved economizer operation by sensing the dry bulb temperature from outdoors plus the enthalpy content of the outdoor air.
- **Dual Enthalpy Sensor** - Additional sensor to single enthalpy sensor. Sensor senses both the return air temperature dry bulb and humidity in conjunction with the single enthalpy to determine the most economical mix. Single Enthalpy sensor also required.
- **Hail Guard Kit** - Kit contains protective grilles made of expanded aluminum with full perimeter frame. Sloped hoods are also included to assure maximum protection.
- **Filter/Frame Kit (Single Phase Only)** - Kit contains the necessary hardware to field install return air filters into the base unit. Pre-cut filter racks and appropriate cleanable standard size filters are shipped in one kit. The filter rack is suitable for either 1" or 2" filters. (1" filter is supplied) This kit is available for single phase horizontal or vertical duct application only. Standard in all 3 Phase models.
- **Motorized Fresh Air Damper** - Designed for duct mounted side supply/return and unit mounted down supply/return applications. Damper capable of providing 0% through 50% of outdoor air (field supplied). Closes on power loss, includes hood and screen assembly.
- **Rectangle To Round Adapters** - Kit includes one supply and one return air rectangle to round duct adapter. Adapters are preformed and designed to fit over current duct openings on the base unit. Transition is from side square duct opening to 14" round duct opening.
- **Roof Curbs** - NRCA approved curbs provide proper fit to base unit for rooftop installations. Curbs are designed to be assembled through hinge pins in each corner. Kit also provides seal strip to assure a water tight seal. 8 and 14 inch high roof curbs are available.
- **Manual Outdoor Damper** - Provides 0% through 50% outdoor air capability (field adjustable). Designed for duct mounted side supply/return applications. Includes hood and screen assembly.
- **Wall Thermostat** - The units are designed to operate with 24-volt electronic and electro-mechanical thermostats. All units can operate with single stage heat/single stage cool thermostats - with or without the economizer.
- **Low Ambient Kit** - Kit provides necessary hardware to convert unit to operate in cooling cycle down to 0° F. Standard unit operation 45° F.
- **Transformer Kit** - Kit provides necessary hardware to provide single phase models from factory furnished 40 VA transformer capability to 75 VA transformer capability. (Required on installations with economizer or motorized damper.)

Guide Specifications

General

Units shall be manufactured by Johnson Controls Unitary Products in an ISO 9001 certified facility. YORK's Affinity™ package units give you the flexibility and choices you need in today's market. These packaged air conditioners are designed for outdoor installation. Only utility and duct connections are required at the point of installation.

Description

Units shall be factory-assembled, single packaged, Electric Cooling units, designed for outdoor mounted installation. For SEER ratings, refer to technical literature. They shall have built in, equal size, field convertible duct connections for down discharge supply/return or horizontal discharge supply/return. The units shall be factory wired, piped, charged with R-410A Refrigerant and factory tested prior to shipment. All unit wiring shall be both numbered and color coded. All units shall be manufactured in a facility certified to ISO 9001 standards, and the cooling performance shall be rated in accordance with DOE and AHRI test procedures. Units shall be CSA listed and classified to ANSI Z21.47/CAN/CSA 2.3 standards and UL 1995/CAN/CSA No. 236-M90 conditions.

Unit Cabinet

Unit cabinet shall be constructed of G-90, pre-paint textured steel, certified at 500 hours salt spray test per ASTM-B117 standards. The unit top shall be a single piece "Water Shed" design, with drip edges and no-seam corners to provide optimum water integrity. Unit shall have a rigidly mounted condenser coil guard to provide protection from objects and personnel after installation. Indoor blower section shall be insulated with up to 3/4" thick, aluminum, foil faced insulation, fastened to prevent insulation from entering the air stream. Cabinet panels shall be "large" size, easily removable for servicing and maintenance, with built-in lift handles. Unit shall be built on a formed, "Super-Structure" design base pan, with embossments at critical points to add strength, rigidity and aid in minimizing sound. Full perimeter base rails shall be provided to assure reliable transit of equipment, overhead rigging, for truck access and proper sealing on roof curb applications. Base rails shall be removable, when required, to lower unit height. Filters shall be furnished and be accessible through a removable access door, sealed airtight. Units vertical discharge and return duct configuration shall be designed to fit between standard 24" O.C. beams without modification to building structure, duct work and base unit. Condensate pan shall be internally sloped and conform to ASHRAE 62-89 self-draining standards, with 3/4" NPTI copper, ridged mount connection.

Indoor (Evaporator) Fan Assembly

Fan shall be direct drive design. Fan wheel shall be double-inlet type with forward-curved blades, dynamically balanced to operate smoothly throughout the entire range of operation.

Airflow design shall be constant air volume. Bearings shall be sealed and permanently lubricated for longer life and no maintenance. Fan assembly shall be "Slip Track" (slide-out) design for easy removal and cleaning.

Outdoor (Condenser) Fan Assembly

The outdoor fan shall be of the direct-driven propeller type, discharge air vertically, have aluminum blades riveted to corrosion resistant steel spider bracket and shall be statically balanced for smooth operation. The outdoor fan motor shall be totally enclosed with permanently lubricated bearings and internally protected against overload conditions.

Refrigerant Components

Compressors:

- a. Shall be fully hermetic type, direct drive, internally protected with internal high-pressure relief and over temperature protection. The hermetic motor shall be suction gas cooled and have a voltage range of +/- 10% of the unit nameplate voltage.
- b. Shall have internal isolation and sound muffling to minimize vibration and noise, and be externally isolated on a dedicated, independent mounting.

Coils:

- a. Evaporator coils shall have aluminum plate fins mechanically bonded to seamless internally enhanced copper tubes with all joints brazed.
- b. Evaporator coil shall be of the direct expansion, draw through design.
- c. Condenser coils shall have aluminum plate fins mechanically bonded to seamless internally enhanced copper tubes with all joints brazed or Micro-Channel aluminum tube, aluminum fins.
- d. Condenser coil shall be draw through design.

Refrigerant Circuit and Refrigerant Safety Components shall include:

- a. Independent fixed orifice expansion devices.
- b. Filter/strainer to eliminate any foreign matter.

Electric Heating Section (Field Install Accessory)

An electric heating section, with nickel chromium elements, shall be provided in a range of 5 thru 25 KW. The heating section shall have a primary limit control(s) (automatic reset) to prevent the heating element system from operating at an excessive temperature. The Heating Section assembly shall slide out of the unit for easy maintenance and service. Units with Electric Heating Sections shall be wired for a single point power supply with branch circuit fusing (where required).

Physical Data

DEQ024-060 Physical Data

Component	Models					
	DEQ024	DEQ030	DEQ036	DEQ042	DEQ048	DEQ060
Nominal Tonnage	2.0	2.5	3.0	3.5	4.0	5.0
AHRI COOLING PERFORMANCE						
Gross Capacity @ AHRI A point (Btu)	23.3	32.3	36.9	43.5	49.0	58.0
AHRI net capacity (Btu)	23.0	31.0	36.0	42.0	47.0	56.0
EER	12.0	12.0	12.0	12.1	12.0	12.0
SEER	14.3	14.1	14.0	14.2	14.0	14.0
Nominal CFM	800	900	1150	1400	1500	1550
System power (KW)	1.92	2.58	3.00	3.47	3.92	4.67
Refrigerant type	R-410A	R-410A	R-410A	R-410A	R-410A	R-410A
Refrigerant charge (lb-oz)	5-0	7-8	8-2	7-12	10-10	10-4
DIMENSIONS (inches)						
Length	49 1/8	49 1/8	49 1/8	49 1/8	49 1/8	49 1/8
Width	47 1/4	47 1/4	47 1/4	47 1/4	47 1/4	47 1/4
Height	33 1/2	33 1/2	33 1/2	41 1/2	41 1/2	41 1/2
OPERATING WT. (lbs.)	346	386	396	406	440	452
COMPRESSORS						
Type	Recip	Recip	Recip	Recip	Scroll	Scroll
Quantity	1	1	1	1	1	1
CONDENSER COIL DATA						
Face area (Sq. Ft.)	11.7	11.7	11.7	16.4	16.4	16.4
Rows	1	2	2	1	2	2
Fins per inch	20	20	20	20	20	20
Tube diameter (in.)	3/8	3/8	3/8	3/8	3/8	3/8
Circuitry Type	Interlaced	Interlaced	Interlaced	Interlaced	Interlaced	Interlaced
EVAPORATOR COIL DATA						
Face area (Sq. Ft.)	4.38	4.38	4.38	5.63	5.63	5.63
Rows	2	2	3	3	3	3
Fins per inch	15	15	15	16	16	16
Tube diameter	3/8	3/8	3/8	3/8	3/8	3/8
Circuitry Type	Interlaced	Interlaced	Interlaced	Interlaced	Interlaced	Interlaced
Refrigerant control	Orifice	Orifice	Orifice	Orifice	Orifice	TX Valve
CONDENSER FAN DATA						
Fan diameter (Inch)	22	22	22	22	22	22
Type	Prop	Prop	Prop	Prop	Prop	Prop
Drive type	Direct	Direct	Direct	Direct	Direct	Direct
No. speeds	1	1	1	1	1	1
Number of motors	1	1	1	1	1	1
Motor HP each	1/4	1/4	1/4	1/4	1/3	1/3
RPM	850	850	850	1100	1100	1100
Nominal total CFM	1800	1800	2400	3000	3000	3000
DIRECT DRIVE EVAP FAN DATA						
Quantity	1	1	1	1	1	1
Fan Size (Inch)	10 x 8	10 x 8	10 x 8	11 x 10	11 x 10	11 x 10
Type	Centrifugal	Centrifugal	Centrifugal	Centrifugal	Centrifugal	Centrifugal
No. speeds	1	1	1	1	1	1
Motor HP each	1/2	1/2	1/2	3/4	3/4	1
RPM	Variable	Variable	Variable	Variable	Variable	Variable
Frame size	48	48	48	48	48	48
FILTERS						
Quantity - Size	2 - 22 x 14 x 1	2 - 22 x 14 x 1	2 - 22 x 14 x 1	2 - 22 x 14 x 1	2 - 22 x 14 x 1	2 - 22 x 14 x 1

Unit Limitations

Size (Tons)	Model	Unit Voltage	Unit Limitations		
			Applied Voltage		Outdoor DB Temp
			Min	Max	Max (°F)
024 (2.0)	DEQ	208/230-1-60	187	252	125
030 (2.5)	DEQ	208/230-1-60	187	252	125
036 (3.0)	DEQ	208/230-1-60	187	252	125
		208/230-3-60	187	252	125
		460-3-60	432	504	125
042 (3.5)	DEQ	208/230-1-60	187	252	125
048 (4.0)	DEQ	208/230-1-60	187	252	125
		208/230-3-60	187	252	125
		460-3-60	432	504	125
060 (5.0)	DEQ	208/230-1-60	187	252	125
		208/230-3-60	187	252	125
		460-3-60	432	504	125

Capacity Performance

DEQ024-060 Cooling Capacities

DEQ024 (2.0 Ton)

Air on		Temperature of Air on Condenser Coil															
Evaporator Coil		Net Capacity ¹ (MBh)	Total Input (kW) ²	Sensible Capacity (MBh)						Net Capacity ¹ (MBh)	Total Input (kW) ²	Sensible Capacity (MBh)					
CFM	WB (°F)			Return Dry Bulb (°F)								Return Dry Bulb (°F)					
				90	85	80	75	70	65			90	85	80	75	70	65
		75°F								85°F							
600	77	27.3	1.5	10.8	8.5	6.2	-	-	-	25.8	1.7	11.7	9.4	7.1	-	-	-
	72	26.2	1.5	16.0	13.7	11.4	9.1	-	-	24.4	1.7	16.0	13.7	11.4	9.1	-	-
	67	25.2	1.5	21.2	18.9	16.6	14.4	12.1	-	22.9	1.7	20.3	18.0	15.7	13.4	11.1	-
	62	23.5	1.5	23.5	21.6	17.9	15.6	13.3	11.0	21.2	1.6	21.2	20.2	17.9	15.6	13.3	11.0
	57	22.6	1.5	22.6	22.6	19.7	17.4	15.1	12.8	20.7	1.6	20.7	20.7	18.9	16.6	14.3	11.9
700	77	28.6	1.5	12.1	9.7	7.2	-	-	-	27.1	1.7	13.1	10.4	7.8	-	-	-
	72	27.5	1.5	18.1	15.5	13.0	10.5	-	-	25.6	1.7	17.8	15.2	12.6	9.9	-	-
	67	26.3	1.5	24.1	21.4	18.9	16.4	13.9	-	24.0	1.7	22.6	19.9	17.3	14.7	12.0	-
	62	24.6	1.5	24.6	23.7	20.4	17.9	15.4	12.9	22.2	1.6	22.2	21.7	19.7	17.1	14.5	11.8
	57	23.6	1.5	23.6	23.6	22.4	19.8	17.3	14.8	21.8	1.6	21.8	21.8	20.8	18.2	15.5	12.9
800	77	29.8	1.5	13.3	10.8	8.1	-	-	-	28.3	1.7	14.5	11.5	8.5	-	-	-
	72	28.7	1.5	20.1	17.4	14.6	11.9	-	-	26.7	1.7	19.7	16.7	13.7	10.8	-	-
	67	27.5	1.5	26.9	23.9	21.2	18.4	15.7	-	25.1	1.7	24.8	21.9	18.9	15.9	13.0	-
	62	25.8	1.5	25.8	25.8	22.9	20.2	17.4	14.7	23.2	1.6	23.2	23.2	21.6	18.6	15.6	12.7
	57	24.7	1.5	24.7	24.7	24.7	22.3	19.6	16.8	22.8	1.6	22.8	22.8	22.8	19.8	16.8	13.9
900	72	30.4	1.5	19.1	15.8	12.5	9.2	-	-	28.4	1.7	20.4	17.1	13.7	10.4	-	-
	67	29.1	1.5	27.0	21.7	18.4	15.1	11.8	-	26.7	1.7	25.6	22.2	18.9	15.6	12.2	-
	62	27.3	1.5	27.3	27.3	20.6	17.3	14.0	10.7	24.7	1.6	24.7	24.7	21.6	18.2	14.9	11.6
	57	26.1	1.5	26.1	26.1	23.0	19.7	16.4	13.2	24.1	1.6	24.1	24.1	22.8	19.4	16.1	12.7
			95°F								105°F						
600	77	24.3	1.9	12.6	10.3	7.9	-	-	-	22.1	2.0	12.7	9.5	7.2	-	-	-
	72	22.5	1.8	16.0	13.7	11.3	9.0	-	-	20.1	2.0	15.1	12.8	10.4	8.1	-	-
	67	20.7	1.8	19.4	17.1	14.7	12.4	10.1	-	18.1	1.9	17.5	16.0	13.7	11.4	9.0	-
	62	18.8	1.8	18.8	18.8	17.9	15.6	13.2	10.9	16.7	1.9	16.7	16.7	16.0	13.7	11.3	9.0
	57	18.9	1.8	18.9	18.9	18.1	15.8	13.4	11.1	17.1	1.9	17.1	17.1	16.3	13.9	11.6	9.3
700	77	25.6	1.9	14.1	11.2	8.4	-	-	-	23.2	2.0	14.6	10.6	7.7	-	-	-
	72	23.7	1.8	17.6	14.8	12.1	9.3	-	-	21.1	2.0	16.7	13.9	11.1	8.4	-	-
	67	21.7	1.8	21.1	18.5	15.7	12.9	10.2	-	19.0	1.9	18.7	17.2	14.6	11.8	9.1	-
	62	19.8	1.8	19.8	19.8	19.1	16.3	13.5	10.8	17.6	1.9	17.6	17.6	17.1	14.3	11.5	8.8
	57	19.9	1.8	19.9	19.9	19.3	16.5	13.8	11.0	17.9	1.9	17.9	17.9	17.3	14.6	11.8	9.0
800	77	26.8	1.9	15.6	12.1	9.0	-	-	-	24.3	2.0	16.6	11.6	8.1	-	-	-
	72	24.8	1.8	19.2	16.0	12.8	9.6	-	-	22.1	2.0	18.2	15.0	11.8	8.6	-	-
	67	22.8	1.8	22.8	19.8	16.6	13.5	10.3	-	19.9	1.9	19.9	18.4	15.5	12.3	9.1	-
	62	20.7	1.8	20.7	20.7	20.2	17.0	13.8	10.7	18.4	1.9	18.4	18.4	18.1	14.9	11.7	8.5
	57	20.8	1.8	20.8	20.8	20.5	17.3	14.1	10.9	18.8	1.9	18.8	18.8	18.4	15.2	12.0	8.8
900	72	26.4	1.8	21.7	18.3	14.9	11.5	-	-	23.6	2.0	20.7	17.2	13.8	10.4	-	-
	67	24.2	1.8	24.2	22.8	19.4	16.0	12.6	-	21.2	2.0	21.2	20.5	18.1	14.7	11.2	-
	62	22.0	1.8	22.0	22.0	22.6	19.2	15.8	12.4	19.6	1.9	19.6	19.6	19.9	16.4	13.0	9.6
	57	22.1	1.8	22.1	22.1	22.5	19.1	15.7	12.3	20.0	1.9	20.0	20.0	20.4	16.9	13.5	10.1

DEQ024 (2.0 Ton) (Continued)

Air on Evaporator Coil		Temperature of Air on Condenser Coil															
		Net Capacity ¹ (MBh)	Total Input (kW) ²	Sensible Capacity (MBh)						Net Capacity ¹ (MBh)	Total Input (kW) ²	Sensible Capacity (MBh)					
				Return Dry Bulb (°F)								Return Dry Bulb (°F)					
				90	85	80	75	70	65			90	85	80	75	70	65
		115°F								125°F							
600	77	19.9	2.2	12.8	8.8	6.5	-	-	-	17.7	2.4	13.6	8.9	5.7	-	-	-
	72	17.7	2.1	14.2	11.9	9.6	7.2	-	-	15.3	2.3	13.3	11.0	8.7	6.4	-	-
	67	15.5	2.1	15.5	15.0	12.6	10.3	8.0	-	13.0	2.2	13.0	13.0	11.6	9.3	7.0	-
	62	14.7	2.1	14.7	14.7	14.1	11.8	9.5	7.2	12.6	2.2	12.6	12.6	12.2	9.9	7.6	5.3
57	15.3	2.1	15.3	15.3	14.4	12.1	9.8	7.5	13.5	2.2	13.5	13.5	12.5	10.2	7.9	5.6	
700	77	20.8	2.2	15.2	10.0	6.9	-	-	-	18.5	2.4	16.0	10.5	6.1	-	-	-
	72	18.5	2.1	15.7	13.0	10.2	7.4	-	-	16.0	2.3	14.8	12.0	9.3	6.5	-	-
	67	16.3	2.1	16.3	16.0	13.5	10.7	8.0	-	13.5	2.2	13.5	13.5	12.4	9.6	6.9	-
	62	15.3	2.1	15.3	15.3	15.0	12.3	9.5	6.8	13.1	2.2	13.1	13.1	13.0	10.3	7.5	4.8
57	16.0	2.1	16.0	16.0	15.4	12.6	9.9	7.1	14.0	2.2	14.0	14.0	13.4	10.7	7.9	5.2	
800	77	21.7	2.2	17.5	11.1	7.3	-	-	-	19.2	2.4	18.5	12.1	6.5	-	-	-
	72	19.4	2.1	17.2	14.0	10.8	7.6	-	-	16.6	2.3	16.3	13.1	9.9	6.6	-	-
	67	17.0	2.1	17.0	17.0	14.3	11.1	7.9	-	14.1	2.2	14.1	14.1	13.2	10.0	6.8	-
	62	16.0	2.1	16.0	16.0	16.0	12.8	9.6	6.4	13.6	2.2	13.6	13.6	13.6	10.7	7.5	4.3
57	16.7	2.1	16.7	16.7	16.3	13.1	9.9	6.7	14.6	2.2	14.6	14.6	14.3	11.1	7.9	4.7	
900	72	20.7	2.2	19.6	16.1	12.7	9.2	-	-	17.9	2.3	18.2	15.1	11.6	8.1	-	-
	67	18.2	2.1	18.2	18.2	16.8	13.3	9.8	-	15.2	2.2	15.2	15.2	15.4	11.9	8.4	-
	62	17.2	2.1	17.2	17.2	17.2	13.7	10.2	6.8	14.7	2.2	14.7	14.7	14.7	10.9	7.4	3.9
	57	17.9	2.1	17.9	17.9	18.2	14.8	11.3	7.8	15.8	2.2	15.8	15.8	16.1	12.6	9.1	5.6

1. These capacities are Net Capacities.

2. These ratings include the compressor, condenser fan and supply air blower motors.

DEQ030 (2.5 Ton)

Air on Evaporator Coil		Temperature of Air on Condenser Coil															
CFM	WB (°F)	Net Capacity ¹ (MBh)	Total Input (kW) ²	Sensible Capacity (MBh)						Net Capacity ¹ (MBh)	Total Input (kW) ²	Sensible Capacity (MBh)					
				Return Dry Bulb (°F)								Return Dry Bulb (°F)					
				90	85	80	75	70	65			90	85	80	75	70	65
				75°F						85°F							
925	77	38.7	2.1	18.3	14.9	11.5	-	-	-	37.1	2.4	17.9	14.4	10.9	-	-	-
	72	38.6	2.1	25.0	21.7	18.3	14.9	-	-	36.4	2.3	24.4	20.9	17.5	14.0	-	-
	67	38.6	2.1	31.8	28.4	25.0	21.7	18.3	-	35.7	2.3	31.0	27.5	24.0	20.6	17.1	-
	62	34.8	2.1	34.8	33.8	30.3	26.9	23.6	20.2	31.8	2.3	31.8	31.2	28.6	25.1	21.7	18.2
	57	33.1	2.1	33.1	33.1	32.5	29.3	25.9	22.5	30.9	2.3	30.9	30.9	30.0	26.5	23.0	19.6
1000	77	38.5	2.1	18.7	15.2	11.8	-	-	-	37.0	2.4	18.4	14.8	11.2	-	-	-
	72	38.5	2.1	25.6	22.1	18.7	15.2	-	-	36.3	2.4	25.2	21.6	18.0	14.4	-	-
	67	38.4	2.1	32.5	29.0	25.5	22.1	18.6	-	35.6	2.3	31.9	28.3	24.7	21.1	17.5	-
	62	34.6	2.1	34.6	34.6	30.9	27.5	24.0	20.5	31.7	2.3	31.7	31.7	29.4	25.8	22.2	18.6
	57	32.9	2.1	32.9	32.9	32.9	29.8	26.4	22.9	30.8	2.3	30.8	30.8	30.8	27.2	23.6	20.0
1075	77	38.3	2.1	19.1	15.6	12.0	-	-	-	36.9	2.4	19.0	15.3	11.6	-	-	-
	72	38.3	2.1	26.1	22.6	19.0	15.5	-	-	36.2	2.4	25.9	22.2	18.5	14.7	-	-
	67	38.2	2.1	33.2	29.6	26.0	22.5	18.9	-	35.5	2.3	32.8	29.1	25.4	21.6	17.9	-
	62	34.4	2.1	34.4	35.4	31.5	28.0	24.4	20.9	31.6	2.3	31.6	32.2	30.2	26.5	22.7	19.0
	57	32.8	2.1	32.8	32.8	33.4	30.4	26.8	23.3	30.7	2.3	30.7	30.7	31.6	27.9	24.2	20.5
1150	72	38.8	2.1	26.9	23.1	19.4	15.6	-	-	36.7	2.4	26.5	22.6	18.7	14.8	-	-
	67	38.8	2.1	34.4	30.2	26.5	22.8	19.0	-	36.0	2.3	33.5	29.6	25.7	21.7	17.8	-
	62	34.9	2.1	34.9	34.9	32.3	28.6	24.9	21.1	32.1	2.3	32.1	32.1	30.6	26.7	22.7	18.8
	57	33.3	2.1	33.3	33.3	29.7	25.9	22.2	-	31.2	2.3	31.2	31.2	31.2	27.2	23.3	19.4
					95°F						105°F						
925	77	35.4	2.6	17.5	13.9	10.3	-	-	-	33.0	2.8	17.7	13.1	9.5	-	-	-
	72	34.1	2.6	23.8	20.2	16.7	13.1	-	-	31.1	2.8	22.7	19.1	15.5	11.9	-	-
	67	32.8	2.5	30.1	26.6	23.0	19.4	15.9	-	29.3	2.7	27.7	25.1	21.5	18.0	14.4	-
	62	28.8	2.5	28.8	28.5	26.9	23.4	19.8	16.2	25.7	2.7	25.7	25.6	24.3	20.7	17.2	13.6
	57	28.7	2.5	28.7	28.5	27.3	23.8	20.2	16.6	26.0	2.7	26.0	25.9	24.8	21.2	17.6	14.0
1000	77	35.4	2.6	18.2	14.4	10.7	-	-	-	33.0	2.8	18.8	13.7	9.9	-	-	-
	72	34.1	2.6	24.7	21.0	17.3	13.5	-	-	31.1	2.8	23.7	19.9	16.1	12.4	-	-
	67	32.8	2.5	31.3	27.6	23.8	20.1	16.4	-	29.3	2.7	28.5	26.2	22.4	18.6	14.9	-
	62	28.8	2.5	28.8	28.8	27.9	24.2	20.4	16.7	25.7	2.7	25.7	25.7	25.3	21.5	17.8	14.0
	57	28.7	2.5	28.7	28.7	28.3	24.6	20.9	17.1	26.0	2.7	26.0	26.0	25.8	22.0	18.2	14.5
1075	77	35.5	2.6	18.9	15.0	11.1	-	-	-	33.0	2.9	20.0	14.2	10.3	-	-	-
	72	34.2	2.6	25.7	21.8	17.9	14.0	-	-	31.1	2.8	24.6	20.7	16.7	12.8	-	-
	67	32.8	2.6	32.5	28.6	24.7	20.8	16.9	-	29.3	2.7	29.3	27.2	23.2	19.3	15.0	-
	62	28.8	2.5	28.8	29.1	28.9	25.0	21.1	17.2	25.7	2.7	25.7	25.9	26.2	22.3	17.7	13.7
	57	28.7	2.5	28.7	28.8	29.3	25.4	21.5	17.6	26.0	2.7	26.0	26.1	26.7	22.8	18.1	14.1
1150	72	34.6	2.6	26.2	22.1	18.0	13.9	-	-	31.5	2.8	25.2	21.1	16.9	12.7	-	-
	67	33.3	2.5	32.7	29.0	24.8	20.7	16.6	-	29.7	2.7	29.4	27.3	23.4	19.3	15.1	-
	62	29.2	2.5	29.2	29.2	28.8	24.7	20.6	16.5	26.1	2.7	26.1	26.1	25.9	21.7	17.6	13.4
	57	29.1	2.5	29.1	29.1	28.9	24.8	20.7	16.6	26.4	2.7	26.4	26.4	26.3	22.1	17.9	13.8

DEQ030 (2.5 Ton) (Continued)

Air on Evaporator Coil		Temperature of Air on Condenser Coil															
		Net Capacity ¹ (MBh)	Total Input (kW) ²	Sensible Capacity (MBh)						Net Capacity ¹ (MBh)	Total Input (kW) ²	Sensible Capacity (MBh)					
				Return Dry Bulb (°F)								Return Dry Bulb (°F)					
				90	85	80	75	70	65			90	85	80	75	70	65
115°F										125°F							
925	77	30.5	3.0	17.9	12.3	8.7	-	-	-	28.0	3.3	18.8	12.3	7.9	-	-	-
	72	28.1	3.0	21.6	18.0	14.4	10.8	-	-	25.1	3.2	20.5	16.9	13.3	9.6	-	-
	67	25.7	2.9	25.4	23.7	20.1	16.5	12.9	-	22.2	3.1	22.2	21.8	18.6	15.0	11.4	-
	62	22.7	2.8	22.7	22.7	21.7	18.1	14.5	10.9	19.6	3.0	19.6	19.6	19.0	15.5	11.9	8.3
57	23.4	2.8	23.4	23.3	22.3	18.7	15.0	11.4	20.7	3.0	20.7	20.7	19.7	16.1	12.5	8.8	
1000	77	30.5	3.1	19.5	12.9	9.1	-	-	-	28.0	3.3	20.9	13.2	8.2	-	-	-
	72	28.1	3.0	22.6	18.8	15.0	11.2	-	-	25.1	3.2	21.5	17.7	13.9	10.1	-	-
	67	25.7	2.9	25.7	24.7	21.0	17.2	13.4	-	22.2	3.1	22.2	22.2	19.5	15.7	11.9	-
	62	22.7	2.9	22.7	22.7	22.7	18.9	15.1	11.3	19.6	3.0	19.6	19.6	19.6	16.2	12.4	8.6
57	23.4	2.9	23.4	23.4	23.2	19.4	15.6	11.8	20.7	3.0	20.7	20.7	20.7	16.9	13.0	9.2	
1075	77	30.5	3.1	21.0	13.4	9.4	-	-	-	28.0	3.3	22.9	14.1	8.6	-	-	-
	72	28.1	3.0	23.6	19.6	15.6	11.7	-	-	25.1	3.2	22.5	18.5	14.5	10.5	-	-
	67	25.7	2.9	26.1	25.8	21.8	17.8	13.9	-	22.2	3.1	22.2	22.6	20.4	16.4	12.0	-
	62	22.7	2.9	22.7	22.7	23.6	19.6	15.7	11.7	19.6	3.1	19.6	19.6	20.3	17.0	12.0	7.9
57	23.4	2.9	23.4	23.4	24.2	20.2	16.2	12.3	20.7	3.1	20.7	20.7	21.6	17.6	12.7	8.7	
1150	72	28.5	3.0	24.2	20.0	15.8	11.6	-	-	25.4	3.2	23.2	18.9	14.7	10.4	-	-
	67	26.1	2.9	26.1	25.7	22.0	17.8	13.6	-	22.5	3.1	22.5	22.5	20.6	16.3	12.1	-
	62	23.0	2.9	23.0	23.0	23.0	18.8	14.5	10.3	19.9	3.0	19.9	19.9	19.9	15.8	11.5	7.2
	57	23.7	2.9	23.7	23.7	23.6	19.4	15.2	11.0	21.0	3.1	21.0	21.0	21.0	16.7	12.4	8.2

1. These capacities are Net Capacities.

2. These ratings include the compressor, condenser fan and supply air blower motors.

DEQ036 (3.0 Ton)

Air on Evaporator Coil		Temperature of Air on Condenser Coil																	
CFM	WB (°F)	Net Capacity ¹ (MBh)	Total Input (kW) ²	Sensible Capacity (MBh)						Net Capacity ¹ (MBh)	Total Input (kW) ²	Sensible Capacity (MBh)							
				Return Dry Bulb (°F)								Return Dry Bulb (°F)							
				90	85	80	75	70	65			90	85	80	75	70	65		
				75°F								85°F							
1000	77	46.0	2.3	23.9	20.3	16.4	-	-	-	43.4	2.6	22.3	18.1	13.9	-	-	-		
	72	44.1	2.3	29.4	25.6	21.7	17.9	-	-	41.2	2.5	28.3	24.1	19.9	15.7	-	-		
	67	42.2	2.3	34.9	30.9	27.0	23.1	19.3	-	38.9	2.5	34.3	30.1	25.9	21.7	17.5	-		
	62	39.0	2.3	39.0	38.3	34.5	30.7	26.8	23.0	35.4	2.5	35.4	35.1	31.7	27.5	23.3	19.1		
	57	32.9	2.3	32.9	32.9	32.6	28.7	24.9	21.0	30.6	2.5	30.6	30.6	29.3	25.1	20.9	16.7		
1100	77	46.5	2.3	24.9	21.0	16.7	-	-	-	43.9	2.6	23.3	18.8	14.4	-	-	-		
	72	44.6	2.3	30.6	26.3	22.1	17.8	-	-	41.7	2.5	29.5	25.0	20.6	16.1	-	-		
	67	42.6	2.3	36.3	31.6	27.4	23.1	18.8	-	39.4	2.5	35.7	31.3	26.8	22.3	17.9	-		
	62	39.4	2.3	39.4	39.1	35.0	30.8	26.5	22.2	35.8	2.5	35.8	35.7	32.8	28.4	23.9	19.4		
	57	33.3	2.3	33.3	33.3	33.1	28.8	24.6	20.3	31.0	2.5	31.0	31.0	30.3	25.8	21.4	16.9		
1200	77	47.0	2.3	25.8	21.7	17.1	-	-	-	44.4	2.6	24.3	19.6	14.9	-	-	-		
	72	45.0	2.3	31.8	27.1	22.4	17.7	-	-	42.1	2.5	30.8	26.0	21.3	16.5	-	-		
	67	43.1	2.3	37.7	32.4	27.7	23.0	18.3	-	39.9	2.5	37.2	32.4	27.7	23.0	18.2	-		
	62	39.8	2.3	39.8	39.8	35.6	30.9	26.2	21.5	36.3	2.5	36.3	36.3	33.9	29.2	24.5	19.7		
	57	33.6	2.3	33.6	33.6	33.6	28.9	24.3	19.6	31.3	2.5	31.3	31.3	31.3	26.6	21.9	17.1		
1300	72	44.7	2.3	34.1	29.0	24.0	18.9	-	-	42.1	2.6	32.5	27.4	22.3	17.2	-	-		
	67	42.8	2.3	41.5	34.8	29.8	24.7	19.7	-	39.9	2.5	39.2	34.1	29.0	23.9	18.8	-		
	62	39.6	2.3	39.6	39.6	38.1	33.1	28.0	23.0	36.3	2.5	36.3	36.3	35.5	30.4	25.3	20.2		
	57	33.4	2.3	33.4	33.4	33.4	28.4	23.3	18.3	31.3	2.5	31.3	31.3	31.3	26.2	21.1	16.0		
					95°F								105°F						
1000	77	40.8	2.8	20.6	15.9	11.3	-	-	-	37.9	3.1	21.3	15.6	11.1	-	-	-		
	72	38.2	2.8	27.1	22.6	18.0	13.5	-	-	34.7	3.0	25.8	21.4	17.0	12.6	-	-		
	67	35.7	2.8	33.6	29.3	24.8	20.2	15.7	-	31.4	3.0	30.4	27.3	23.0	18.6	14.2	-		
	62	31.9	2.7	31.9	31.9	28.9	24.4	19.9	15.3	28.8	2.9	28.8	28.8	26.4	22.0	17.6	13.2		
	57	28.3	2.7	28.3	28.3	26.0	21.4	16.9	12.4	26.6	2.9	26.6	26.6	24.6	20.2	15.8	11.4		
1100	77	41.3	2.8	21.7	16.7	12.0	-	-	-	38.3	3.1	23.1	16.5	11.7	-	-	-		
	72	38.7	2.8	28.4	23.8	19.1	14.5	-	-	35.1	3.0	27.2	22.6	18.0	13.3	-	-		
	67	36.2	2.8	35.1	30.9	26.2	21.6	16.9	-	31.8	3.0	31.3	28.7	24.2	19.6	15.0	-		
	62	32.3	2.7	32.3	32.3	30.6	26.0	21.3	16.6	29.1	2.9	29.1	29.1	27.9	23.2	18.6	14.0		
	57	28.7	2.7	28.7	28.7	27.5	22.8	18.2	13.5	26.9	2.9	26.9	26.9	25.9	21.3	16.7	12.1		
1200	77	41.9	2.8	22.9	17.5	12.7	-	-	-	38.8	3.1	25.0	17.3	12.3	-	-	-		
	72	39.3	2.8	29.8	25.0	20.2	15.4	-	-	35.5	3.0	28.6	23.7	18.9	14.0	-	-		
	67	36.6	2.8	36.6	32.5	27.7	22.9	18.1	-	32.2	3.0	32.2	30.1	25.4	20.6	15.8	-		
	62	32.7	2.7	32.7	32.7	32.3	27.5	22.7	18.0	29.5	2.9	29.5	29.5	29.3	24.4	19.6	14.7		
	57	29.0	2.7	29.0	29.0	29.0	24.2	19.5	14.7	27.3	2.9	27.3	27.3	27.3	22.4	17.6	12.7		
1300	72	39.6	2.8	30.9	25.7	20.6	15.4	-	-	35.8	3.1	30.3	25.0	19.8	14.6	-	-		
	67	36.9	2.8	36.9	33.4	28.2	23.0	17.9	-	32.5	3.0	32.5	30.7	26.7	21.5	16.3	-		
	62	33.0	2.7	33.0	33.0	32.9	27.8	22.6	17.5	29.8	2.9	29.8	29.8	29.7	24.5	19.3	14.1		
	57	29.3	2.7	29.3	29.3	29.3	24.1	19.0	13.8	27.5	3.0	27.5	27.5	27.5	22.3	17.1	11.9		

DEQ036 (3.0 Ton) (Continued)

Air on Evaporator Coil		Temperature of Air on Condenser Coil															
		Net Capacity ¹ (MBh)	Total Input (kW) ²	Sensible Capacity (MBh)						Net Capacity ¹ (MBh)	Total Input (kW) ²	Sensible Capacity (MBh)					
Return Dry Bulb (°F)						Return Dry Bulb (°F)											
90	85			80	75	70	65	90	85			80	75	70	65		
		115°F								125°F							
1000	77	35.0	3.3	22.0	15.3	10.9	-	-	-	32.1	3.6	23.7	15.7	10.7	-	-	-
	72	31.1	3.3	24.6	20.3	16.0	11.8	-	-	27.5	3.5	23.3	19.2	15.0	10.9	-	-
	67	27.2	3.2	27.2	25.3	21.2	16.9	12.7	-	22.9	3.4	22.9	22.8	19.4	15.3	11.2	-
	62	25.7	3.1	25.7	25.7	24.0	19.7	15.4	11.2	22.6	3.3	22.6	22.6	21.5	17.3	13.2	9.1
	57	25.0	3.1	25.0	25.0	23.3	19.0	14.8	10.5	23.3	3.3	23.3	23.3	22.0	17.8	13.7	9.6
1100	77	35.3	3.3	24.5	16.2	11.4	-	-	-	32.3	3.6	26.4	17.4	11.1	-	-	-
	72	31.4	3.3	26.0	21.4	16.8	12.2	-	-	27.7	3.5	24.7	20.2	15.6	11.1	-	-
	67	27.4	3.2	27.4	26.5	22.2	17.6	13.0	-	23.1	3.4	23.1	23.1	20.2	15.6	11.1	-
	62	26.0	3.1	26.0	26.0	25.1	20.5	15.9	11.3	22.8	3.3	22.8	22.8	22.3	17.8	13.2	8.7
	57	25.2	3.1	25.2	25.2	24.4	19.8	15.2	10.6	23.5	3.3	23.5	23.5	22.8	18.3	13.7	9.2
1200	77	35.7	3.4	27.0	17.2	11.9	-	-	-	32.6	3.6	29.1	19.2	11.5	-	-	-
	72	31.7	3.3	27.4	22.5	17.6	12.7	-	-	27.9	3.5	26.2	21.2	16.3	11.3	-	-
	67	27.7	3.2	27.7	27.7	23.2	18.3	13.4	-	23.3	3.4	23.3	23.3	21.0	16.0	11.0	-
	62	26.2	3.1	26.2	26.2	26.2	21.3	16.4	11.5	23.0	3.4	23.0	23.0	23.0	18.2	13.2	8.3
	57	25.5	3.1	25.5	25.5	25.5	20.6	15.7	10.8	23.7	3.4	23.7	23.7	23.7	18.8	13.8	8.8
1300	72	32.1	3.3	29.6	24.4	19.1	13.8	-	-	28.4	3.6	28.4	23.7	18.4	13.0	-	-
	67	28.1	3.2	28.1	28.1	25.2	19.9	14.7	-	23.7	3.4	23.7	23.7	23.7	18.4	13.1	-
	62	26.6	3.2	26.6	26.6	26.6	21.3	16.0	10.7	23.4	3.4	23.4	23.4	23.4	18.0	12.7	7.4
		57	25.8	3.2	25.8	25.8	25.8	20.6	15.3	10.0	24.1	3.4	24.1	24.1	24.1	18.8	13.4

1. These capacities are Net Capacities.

2. These ratings include the compressor, condenser fan and supply air blower motors.

DEQ042 (3.5 Ton)

Air on Evaporator Coil		Temperature of Air on Condenser Coil																	
CFM	WB (°F)	Net Capacity ¹ (MBh)	Total Input (kW) ²	Sensible Capacity (MBh)						Net Capacity ¹ (MBh)	Total Input (kW) ²	Sensible Capacity (MBh)							
				Return Dry Bulb (°F)								Return Dry Bulb (°F)							
				90	85	80	75	70	65			90	85	80	75	70	65		
				75°F						85°F									
1200	77	58.6	2.9	27.7	23.2	17.8	-	-	-	54.9	3.2	27.8	22.3	16.7	-	-	-		
	72	54.7	2.8	36.7	31.3	25.8	20.4	-	-	50.8	3.1	35.5	29.9	24.4	-	-	-		
	67	50.8	2.8	45.7	39.3	33.9	28.4	23.0	-	46.7	3.0	43.1	37.6	32.0	26.5	20.9	-		
	62	46.3	2.7	46.3	46.2	42.8	37.3	31.9	26.5	42.8	2.9	42.8	42.7	39.3	33.7	28.2	22.6		
	57	45.4	2.6	45.4	45.4	43.0	37.5	32.1	26.7	42.3	2.9	42.3	42.3	39.9	34.3	28.8	23.2		
1300	77	58.7	2.9	27.9	23.9	18.3	-	-	-	55.0	3.2	28.8	23.0	17.2	-	-	-		
	72	54.8	2.8	37.7	32.1	26.6	21.0	-	-	50.9	3.1	36.7	30.9	25.2	19.4	-	-		
	67	50.9	2.7	47.6	40.4	34.8	29.2	23.6	-	46.8	3.0	44.6	38.8	33.1	27.3	21.5	-		
	62	46.3	2.7	46.3	46.3	44.0	38.4	32.8	27.2	42.9	2.9	42.9	42.8	40.6	34.8	29.0	23.2		
	57	45.4	2.5	45.4	45.4	44.2	38.6	33.0	27.4	42.4	2.8	42.4	42.4	41.2	35.4	29.6	23.8		
1400	77	58.7	2.9	28.1	24.5	18.8	-	-	-	55.1	3.2	29.8	23.8	17.8	-	-	-		
	72	54.8	2.8	38.8	33.0	27.3	21.5	-	-	51.0	3.1	38.0	32.0	25.9	19.9	-	-		
	67	50.9	2.7	49.4	41.5	35.8	30.0	24.3	-	46.8	3.0	46.1	40.1	34.1	28.1	22.1	-		
	62	46.3	2.7	46.3	46.3	45.2	39.4	33.7	27.9	42.9	2.9	42.9	42.9	41.9	35.8	29.8	23.8		
	57	45.4	2.5	45.4	45.4	45.4	39.7	33.9	28.2	42.5	2.8	42.5	42.5	42.5	36.5	30.5	24.5		
1500	72	55.8	2.8	41.3	35.1	28.9	22.8	-	-	51.5	3.1	39.8	33.4	27.0	20.5	-	-		
	67	51.8	2.8	51.1	44.1	38.0	31.8	25.7	-	47.4	3.0	47.0	41.8	35.4	29.0	22.6	-		
	62	47.2	2.7	47.2	47.2	46.6	40.5	34.3	28.2	43.4	2.9	43.4	43.4	42.9	36.5	30.0	23.6		
	57	46.2	2.5	46.2	46.2	46.2	40.1	33.9	27.8	43.0	2.8	43.0	43.0	43.0	36.6	30.1	23.7		
					95°F						105°F								
1200	77	51.2	3.4	27.9	21.3	15.6	-	-	-	46.6	3.7	28.1	20.0	14.1	-	-	-		
	72	46.8	3.3	34.2	28.6	22.9	17.2	-	-	42.2	3.6	32.5	26.8	21.2	15.5	-	-		
	67	42.5	3.2	40.6	35.8	30.1	24.5	18.8	-	37.8	3.5	36.9	33.7	28.3	22.6	16.9	-		
	62	39.3	3.2	39.3	39.2	35.8	30.1	24.4	18.8	34.7	3.4	34.7	34.7	31.7	26.1	20.4	14.7		
	57	39.3	3.1	39.3	39.3	36.8	31.1	25.4	19.7	35.2	3.4	35.2	35.2	33.0	27.3	21.7	16.0		
1300	77	51.3	3.4	29.7	22.2	16.2	-	-	-	46.9	3.7	30.4	21.1	14.6	-	-	-		
	72	47.0	3.3	35.7	29.7	23.7	17.8	-	-	42.5	3.6	34.0	28.0	22.0	16.1	-	-		
	67	42.7	3.2	41.7	37.3	31.3	25.3	19.3	-	38.1	3.4	37.6	35.0	29.5	23.5	17.5	-		
	62	39.4	3.2	39.4	39.4	37.2	31.2	25.2	19.2	34.9	3.4	34.9	34.9	33.0	27.1	21.1	15.1		
	57	39.5	3.1	39.5	39.5	38.2	32.2	26.2	20.3	35.5	3.4	35.5	35.5	34.4	28.4	22.4	16.4		
1400	77	51.5	3.4	31.5	23.1	16.8	-	-	-	47.2	3.7	32.7	22.1	15.2	-	-	-		
	72	47.2	3.3	37.2	30.9	24.6	18.3	-	-	42.8	3.6	35.5	29.2	22.9	16.6	-	-		
	67	42.8	3.2	42.8	38.7	32.4	26.2	19.9	-	38.4	3.4	38.4	36.3	30.6	24.3	18.1	-		
	62	39.5	3.1	39.5	39.5	38.5	32.3	26.0	19.7	35.2	3.4	35.2	35.2	34.4	28.1	21.8	15.5		
	57	39.6	3.1	39.6	39.6	39.6	33.3	27.0	20.8	35.7	3.4	35.7	35.7	35.7	29.4	23.2	16.9		
1500	72	47.3	3.3	38.3	31.6	25.0	18.3	-	-	42.6	3.6	36.4	29.7	23.0	16.3	-	-		
	67	42.9	3.2	42.9	39.6	32.9	26.2	19.6	-	38.2	3.4	38.2	36.5	30.7	24.0	17.3	-		
	62	39.6	3.1	39.6	39.6	39.1	32.4	25.8	19.1	35.0	3.4	35.0	35.0	34.5	27.8	21.1	14.4		
	57	39.7	3.1	39.7	39.7	39.7	33.0	26.4	19.7	35.6	3.4	35.6	35.6	35.6	28.9	22.2	15.5		

DEQ042 (3.5 Ton) (Continued)

Air on Evaporator Coil		Temperature of Air on Condenser Coil															
		Net Capacity ¹ (MBh)	Total Input (kW) ²	Sensible Capacity (MBh)						Net Capacity ¹ (MBh)	Total Input (kW) ²	Sensible Capacity (MBh)					
				Return Dry Bulb (°F)								Return Dry Bulb (°F)					
				90	85	80	75	70	65			90	85	80	75	70	65
		115°F								125°F							
1200	77	42.0	4.0	28.4	18.7	12.5	-	-	-	37.4	4.2	29.6	18.3	11.0	-	-	-
	72	37.6	3.8	30.8	25.1	19.5	13.8	-	-	32.9	4.0	29.0	23.4	17.7	12.1	-	-
	67	33.2	3.7	33.2	31.5	26.4	20.7	15.1	-	28.5	3.9	28.5	28.5	24.5	18.9	13.2	-
	62	30.1	3.6	30.1	30.1	27.6	22.0	16.3	10.7	25.5	3.8	25.5	25.5	23.5	17.9	12.3	6.6
57	31.2	3.6	31.2	31.2	29.2	23.5	17.9	12.2	27.1	3.9	27.1	27.1	25.4	19.7	14.1	8.5	
1300	77	42.4	4.0	31.1	19.9	13.1	-	-	-	38.0	4.2	32.2	20.3	11.5	-	-	-
	72	38.0	3.8	32.3	26.3	20.3	14.4	-	-	33.5	4.0	30.6	24.6	18.7	12.7	-	-
	67	33.5	3.7	33.5	32.7	27.6	21.6	15.7	-	29.0	3.9	29.0	29.0	25.8	19.8	13.8	-
	62	30.4	3.6	30.4	30.4	28.9	22.9	16.9	11.0	26.0	3.8	26.0	26.0	24.8	18.8	12.8	6.8
57	31.5	3.6	31.5	31.5	30.5	24.5	18.6	12.6	27.5	3.9	27.5	27.5	26.7	20.7	14.7	8.8	
1400	77	42.9	4.0	33.8	21.2	13.7	-	-	-	38.6	4.2	34.9	22.3	12.1	-	-	-
	72	38.4	3.8	33.9	27.5	21.2	14.9	-	-	34.0	4.1	32.2	25.9	19.6	13.2	-	-
	67	33.9	3.7	33.9	33.9	28.8	22.5	16.2	-	29.5	3.9	29.5	29.5	27.0	20.7	14.4	-
	62	30.8	3.6	30.8	30.8	30.2	23.9	17.6	11.3	26.4	3.8	26.4	26.4	26.0	19.7	13.4	7.0
57	31.9	3.6	31.9	31.9	31.9	25.6	19.3	13.0	28.0	3.9	28.0	28.0	28.0	21.7	15.4	9.0	
1500	72	38.0	3.8	34.5	27.8	21.0	14.3	-	-	33.3	4.0	32.6	25.8	19.1	12.3	-	-
	67	33.5	3.7	33.5	33.5	28.5	21.8	15.1	-	28.8	3.9	28.8	28.8	26.4	19.6	12.8	-
	62	30.4	3.6	30.4	30.4	29.9	23.1	16.4	9.7	25.9	3.8	25.9	25.9	25.3	18.5	11.8	5.0
	57	31.5	3.6	31.5	31.5	31.5	24.8	18.1	11.3	27.4	3.9	27.4	27.4	27.4	20.7	13.9	7.2

1. These capacities are Net Capacities.

2. These ratings include the compressor, condenser fan and supply air blower motors.

DEQ048 (4.0 Ton)

Air on Evaporator Coil		Temperature of Air on Condenser Coil																																	
		Net Capacity ¹ (MBh)	Total Input (kW) ²	Sensible Capacity (MBh)						Net Capacity ¹ (MBh)	Total Input (kW) ²	Sensible Capacity (MBh)																							
				Return Dry Bulb (°F)								Return Dry Bulb (°F)																							
CFM	WB (°F)			90	85	80	75	70	65			90	85	80	75	70	65																		
75°F																		85°F																	
1400	77	58.8	2.6	31.6	26.4	20.6	-	-	-	56.2	3.0	31.9	25.9	20.1	-	-	-																		
	72	55.0	2.6	40.1	34.3	28.5	22.7	-	-	52.6	3.0	39.6	33.8	27.9	22.0	-	-																		
	67	51.2	2.6	48.6	42.2	36.4	30.6	24.8	-	49.0	3.0	47.3	41.6	35.7	29.8	24.0	-																		
	62	45.7	2.6	45.7	45.7	44.3	38.6	32.8	27.0	45.7	2.9	45.7	45.7	43.2	37.3	31.5	25.6																		
	57	45.6	2.5	45.6	45.6	41.7	35.9	30.2	24.4	44.2	2.9	44.2	44.2	40.7	34.8	29.0	23.1																		
1500	77	58.8	2.6	32.5	27.5	21.2	-	-	-	56.0	3.0	33.2	26.8	20.5	-	-	-																		
	72	55.0	2.6	41.9	35.6	29.4	23.2	-	-	52.4	3.0	41.0	34.8	28.5	22.3	-	-																		
	67	51.2	2.6	51.2	43.8	37.6	31.4	25.2	-	48.8	3.0	48.8	42.8	36.5	30.3	24.0	-																		
	62	45.7	2.6	45.7	45.7	45.7	39.6	33.4	27.2	45.5	3.0	45.5	45.5	44.2	38.0	31.7	25.5																		
	57	45.6	2.5	45.6	45.6	43.1	36.9	30.7	24.5	44.1	2.9	44.1	44.1	41.6	35.4	29.1	22.9																		
1650	72	55.0	2.6	44.3	37.6	30.9	24.2	-	-	52.0	3.0	43.4	36.7	29.9	23.2	-	-																		
	67	51.2	2.6	51.2	46.7	39.5	32.8	26.1	-	48.5	3.0	48.5	45.1	38.3	31.6	24.8	-																		
	62	45.7	2.6	45.7	45.7	45.7	39.1	32.4	25.7	45.2	3.0	45.2	45.2	44.5	37.8	31.0	24.2																		
	57	45.6	2.5	45.6	45.6	44.3	37.6	30.9	24.2	43.8	2.9	43.8	43.8	42.5	35.8	29.0	22.2																		
1800	72	54.9	2.6	46.7	39.6	32.4	25.2	-	-	51.6	3.0	45.9	38.6	31.3	24.0	-	-																		
	67	51.1	2.6	51.1	49.7	41.4	34.2	27.0	-	48.1	3.0	48.1	47.4	40.1	32.8	25.6	-																		
	62	45.7	2.6	45.7	45.7	45.7	38.5	31.4	24.2	44.8	2.9	44.8	44.8	44.8	37.6	30.3	23.0																		
	57	45.6	2.5	45.6	45.6	45.6	38.4	31.2	24.0	43.4	2.9	43.4	43.4	43.4	36.2	28.9	21.6																		
95°F																		105°F																	
1400	77	53.5	3.4	32.2	25.5	19.6	-	-	-	50.4	3.8	32.6	24.5	18.5	-	-	-																		
	72	50.2	3.3	39.2	33.2	27.3	21.4	-	-	47.3	3.8	38.3	32.2	26.2	20.2	-	-																		
	67	46.8	3.3	46.1	41.0	35.0	29.1	23.1	-	44.3	3.8	43.9	40.0	34.0	27.9	21.9	-																		
	62	45.6	3.3	45.6	45.6	42.1	36.1	30.2	24.3	43.6	3.7	43.6	43.2	39.0	33.0	27.0	20.9																		
	57	42.9	3.3	42.9	42.9	39.6	33.7	27.8	21.8	42.5	3.7	42.5	42.1	38.0	32.0	26.0	20.0																		
1500	77	53.1	3.4	33.9	26.1	19.8	-	-	-	49.9	3.8	35.2	25.2	18.8	-	-	-																		
	72	49.8	3.3	40.2	33.9	27.6	21.4	-	-	46.8	3.8	39.5	33.1	26.7	20.3	-	-																		
	67	46.4	3.3	46.4	41.7	35.5	29.2	22.9	-	43.8	3.7	43.8	41.0	34.6	28.2	21.8	-																		
	62	45.2	3.3	45.2	45.2	42.6	36.3	30.1	23.8	43.1	3.7	43.1	43.1	39.7	33.3	26.9	20.5																		
	57	42.5	3.3	42.5	42.5	40.1	33.9	27.6	21.3	42.0	3.7	42.0	42.0	38.7	32.3	25.9	19.5																		
1650	72	49.1	3.3	42.6	35.8	28.9	22.1	-	-	45.8	3.8	41.3	34.7	27.8	20.9	-	-																		
	67	45.7	3.3	45.7	43.4	37.1	30.3	23.5	-	42.8	3.7	42.8	41.4	36.0	29.1	22.1	-																		
	62	44.6	3.3	44.6	44.6	43.3	36.5	29.6	22.8	42.2	3.7	42.2	42.2	40.4	33.5	26.6	19.6																		
	57	41.9	3.3	41.9	41.9	40.7	33.9	27.1	20.3	41.1	3.7	41.1	41.1	39.4	32.5	25.5	18.6																		
1800	72	48.3	3.3	45.0	37.6	30.2	22.9	-	-	44.8	3.8	43.1	36.4	28.9	21.5	-	-																		
	67	45.1	3.3	45.1	45.1	38.8	31.5	24.1	-	41.9	3.7	41.9	41.9	37.5	30.0	22.5	-																		
	62	44.0	3.3	44.0	44.0	44.0	36.6	29.2	21.8	41.2	3.7	41.2	41.2	41.2	33.7	26.3	18.8																		
	57	41.3	3.3	41.3	41.3	41.3	33.9	26.6	19.2	40.1	3.7	40.1	40.1	40.1	32.6	25.2	17.7																		

DEQ048 (4.0 Ton) (Continued)

Air on Evaporator Coil		Temperature of Air on Condenser Coil															
		Net Capacity ¹ (MBh)	Total Input (kW) ²	Sensible Capacity (MBh)						Net Capacity ¹ (MBh)	Total Input (kW) ²	Sensible Capacity (MBh)					
				Return Dry Bulb (°F)								Return Dry Bulb (°F)					
				90	85	80	75	70	65			90	85	80	75	70	65
		115°F								125°F							
1400	77	47.2	4.2	32.9	23.5	17.4	-	-	-	44.1	4.6	33.6	23.0	16.4	-	-	-
	72	44.5	4.2	37.4	31.3	25.2	19.1	-	-	41.7	4.6	36.4	30.3	24.1	17.9	-	-
	67	41.8	4.2	41.8	39.0	32.9	26.8	20.7	-	39.3	4.6	39.3	38.0	31.8	25.6	19.5	-
	62	41.5	4.2	41.5	40.8	35.9	29.8	23.7	17.6	39.5	4.6	39.5	38.5	32.8	26.6	20.5	14.3
	57	42.0	4.2	42.0	41.4	36.4	30.3	24.2	18.1	41.6	4.6	41.6	40.6	34.8	28.6	22.5	16.3
1500	77	46.6	4.2	36.4	24.4	17.9	-	-	-	43.4	4.6	37.7	24.3	16.9	-	-	-
	72	43.9	4.2	38.8	32.3	25.8	19.2	-	-	41.0	4.6	38.2	31.5	24.8	18.2	-	-
	67	41.2	4.2	41.2	40.2	33.7	27.1	20.6	-	38.6	4.6	38.6	38.6	32.8	26.1	19.4	-
	62	41.0	4.1	41.0	41.0	36.8	30.2	23.7	17.2	38.8	4.6	38.8	38.8	33.8	27.2	20.5	13.8
	57	41.5	4.1	41.5	41.5	37.3	30.8	24.2	17.7	41.0	4.6	41.0	41.0	35.9	29.2	22.5	15.9
1650	72	42.6	4.2	40.0	33.7	26.7	19.6	-	-	39.3	4.6	38.7	32.7	25.6	18.4	-	-
	67	39.9	4.2	39.9	39.4	34.9	27.8	20.8	-	37.0	4.6	37.0	37.0	33.7	26.6	19.4	-
	62	39.7	4.2	39.7	39.7	37.6	30.5	23.5	16.4	37.3	4.6	37.3	37.3	34.8	27.6	20.4	13.3
	57	40.2	4.1	40.2	40.2	38.1	31.1	24.0	17.0	39.3	4.6	39.3	39.3	36.8	29.6	22.5	15.3
1800	72	41.2	4.2	41.2	35.2	27.6	20.1	-	-	37.6	4.6	37.6	34.0	26.3	18.6	-	-
	67	38.7	4.2	38.7	38.7	36.1	28.5	21.0	-	35.4	4.6	35.4	35.4	34.7	27.1	19.4	-
	62	38.4	4.2	38.4	38.4	38.4	30.9	23.3	15.7	35.7	4.6	35.7	35.7	35.7	28.0	20.4	12.7
	57	38.9	4.2	38.9	38.9	38.9	31.4	23.8	16.2	37.7	4.6	37.7	37.7	37.7	30.1	22.4	14.7

1. These capacities are Net Capacities.

2. These ratings include the compressor, condenser fan and supply air blower motors.

DEQ060 (5.0 Ton)

Air on Evaporator Coil		Temperature of Air on Condenser Coil																		
CFM	WB (°F)	Net Capacity ¹ (MBh)	Total Input (kW) ²	Sensible Capacity (MBh)						Net Capacity ¹ (MBh)	Total Input (kW) ²	Sensible Capacity (MBh)								
				Return Dry Bulb (°F)								Return Dry Bulb (°F)								
				90	85	80	75	70	65			90	85	80	75	70	65			
				75°F						85°F										
1500	77	78.3	3.4	36.3	30.3	24.2	-	-	-	72.6	3.8	34.7	28.6	22.6	-	-	-			
	72	71.4	3.3	45.4	39.3	33.3	27.2	-	-	66.6	3.8	43.8	37.7	31.7	25.6	-	-			
	67	64.4	3.2	54.4	48.4	42.3	36.3	30.3	-	60.6	3.7	52.9	46.8	40.8	34.7	28.6	-			
	62	59.1	3.2	59.1	58.9	51.7	45.7	39.7	33.6	55.9	3.7	55.9	55.8	49.7	43.7	37.6	31.6			
	57	57.4	3.7	57.4	57.4	53.4	47.4	41.3	35.3	56.8	3.7	56.8	56.8	51.7	45.6	39.6	33.5			
1650	77	79.0	3.4	38.2	31.7	25.2	-	-	-	73.0	3.8	36.5	30.0	23.5	-	-	-			
	72	72.0	3.3	47.6	41.1	34.6	28.1	-	-	67.0	3.8	45.9	39.4	32.9	26.4	-	-			
	67	65.0	3.2	57.1	50.6	44.1	37.6	31.1	-	61.0	3.7	55.3	48.8	42.3	35.8	29.3	-			
	62	59.6	3.2	59.6	59.5	53.8	47.3	40.8	34.3	56.2	3.7	56.2	56.2	51.6	45.1	38.6	32.1			
	57	57.9	3.7	57.9	57.9	55.6	49.1	42.6	36.1	57.2	3.7	57.2	57.2	53.7	47.2	40.7	34.2			
1800	77	79.7	3.4	40.1	33.2	26.2	-	-	-	73.5	3.8	38.3	31.3	24.3	-	-	-			
	72	72.6	3.3	49.9	43.0	36.0	29.0	-	-	67.4	3.8	48.0	41.1	34.1	27.2	-	-			
	67	65.6	3.3	59.7	52.8	45.8	38.8	31.9	-	61.4	3.7	57.8	50.9	43.9	36.9	30.0	-			
	62	60.2	3.2	60.2	60.2	56.0	49.0	42.0	35.1	56.6	3.7	56.6	56.6	53.6	46.6	39.7	32.7			
	57	58.5	3.7	58.5	58.5	57.8	50.8	43.8	36.9	57.5	3.7	57.5	57.5	55.7	48.7	41.8	34.8			
1900	72	73.3	3.3	51.4	44.2	37.0	29.8	-	-	67.8	3.8	49.5	42.3	35.1	27.9	-	-			
	67	66.2	3.2	62.4	54.2	47.0	39.9	32.7	-	61.7	3.7	59.5	52.3	45.1	37.9	30.7	-			
	62	60.8	3.2	60.8	60.8	58.1	50.9	43.7	36.5	56.9	3.7	56.9	56.9	55.1	47.9	40.7	33.5			
	57	59.1	3.7	59.1	59.1	58.7	51.5	44.4	37.2	57.8	3.7	57.8	57.8	56.9	49.7	42.5	35.3			
	72	74.1	3.3	52.8	45.4	38.0	30.6	-	-	68.1	3.8	50.9	43.4	36.0	28.6	-	-			
2000	67	66.9	3.2	65.2	55.7	48.3	40.9	33.5	-	62.0	3.7	61.2	53.8	46.3	38.9	31.5	-			
	62	61.4	3.2	61.4	61.4	60.2	52.8	45.3	37.9	57.2	3.7	57.2	57.2	56.6	49.1	41.7	34.3			
	57	59.7	3.7	59.7	59.7	59.7	52.3	44.9	37.5	58.1	3.7	58.1	58.1	50.7	43.3	35.8	-			
					95°F						105°F									
	1500	77	66.8	4.3	33.1	27.0	20.9	-	-	-	61.8	4.8	31.1	25.1	19.1	-	-	-		
72		61.8	4.3	42.2	36.1	30.1	24.0	-	-	57.1	4.8	40.2	34.1	28.1	22.1	-	-			
67		56.9	4.2	51.3	45.3	39.2	33.1	27.0	-	52.3	4.7	49.2	43.2	37.2	31.1	25.1	-			
62		52.6	4.2	52.6	52.6	47.7	41.6	35.6	29.5	48.8	4.7	48.8	48.8	44.6	38.6	32.5	26.5			
57		56.2	3.7	56.2	56.0	49.9	43.9	37.8	31.7	51.5	4.5	51.5	51.4	45.6	39.6	33.5	27.5			
1650	77	67.0	4.3	34.7	28.2	21.7	-	-	-	61.9	4.8	33.8	26.3	19.8	-	-	-			
	72	62.0	4.3	44.2	37.7	31.2	24.6	-	-	57.2	4.8	42.2	35.7	29.2	22.7	-	-			
	67	57.1	4.2	53.6	47.1	40.6	34.1	27.6	-	52.4	4.7	50.5	45.1	38.6	32.1	25.6	-			
	62	52.8	4.2	52.8	52.8	49.4	42.9	36.4	29.9	48.9	4.7	48.9	48.9	46.3	39.8	33.4	26.9			
	57	56.4	3.7	56.4	56.3	51.8	45.2	38.7	32.2	51.5	4.5	51.5	51.5	47.4	40.9	34.4	27.9			
1800	77	67.2	4.3	36.4	29.4	22.5	-	-	-	62.0	4.8	36.5	27.5	20.5	-	-	-			
	72	62.3	4.2	46.2	39.2	32.2	25.3	-	-	57.2	4.8	44.2	37.2	30.3	23.3	-	-			
	67	57.3	4.2	55.9	49.0	42.0	35.1	28.1	-	52.5	4.7	51.8	47.0	40.0	33.1	26.2	-			
	62	53.0	4.2	53.0	53.0	51.2	44.2	37.3	30.3	49.0	4.7	49.0	49.0	48.1	41.1	34.2	27.2			
	57	56.6	3.7	56.6	56.6	53.6	46.6	39.7	32.7	51.6	4.5	51.6	51.6	49.1	42.2	35.3	28.3			
1900	72	62.2	4.3	47.5	40.3	33.2	26.0	-	-	57.0	4.8	45.4	38.3	31.1	23.9	-	-			
	67	57.2	4.2	56.6	50.4	43.2	36.0	28.8	-	52.2	4.7	51.9	48.1	41.1	33.9	26.8	-			
	62	53.0	4.2	53.0	53.0	52.1	44.9	37.7	30.5	48.7	4.7	48.7	48.7	48.3	41.1	33.9	26.8			
	57	56.5	3.7	56.5	56.5	55.0	47.9	40.7	33.5	51.4	4.5	51.4	51.4	50.1	43.0	35.8	28.6			
	72	62.2	4.3	48.9	41.5	34.1	26.6	-	-	56.7	4.8	46.7	39.3	31.9	24.5	-	-			
2000	67	57.2	4.2	57.2	51.8	44.4	37.0	29.5	-	52.0	4.7	52.0	49.3	42.2	34.8	27.4	-			
	62	52.9	4.2	52.9	52.9	52.9	45.5	38.1	30.6	48.5	4.7	48.5	48.5	48.5	41.1	33.7	26.3			
	57	56.5	3.7	56.5	56.5	56.5	49.1	41.7	34.2	51.1	4.5	51.1	51.1	51.1	43.7	36.3	28.9			

DEQ060 (5.0 Ton) (Continued)

Air on Evaporator Coil		Temperature of Air on Condenser Coil															
CFM	WB (°F)	Net Capacity ¹ (MBh)	Total Input (kW) ²	Sensible Capacity (MBh)						Net Capacity ¹ (MBh)	Total Input (kW) ²	Sensible Capacity (MBh)					
				Return Dry Bulb (°F)								Return Dry Bulb (°F)					
				90	85	80	75	70	65			90	85	80	75	70	65
				115°F						125°F							
1500	77	56.8	5.3	29.2	23.2	17.2	-	-	-	51.8	5.8	28.9	21.2	15.3	-	-	-
	72	52.3	5.3	38.1	32.1	26.1	20.1	-	-	47.5	5.8	36.1	30.1	24.2	18.2	-	-
	67	47.8	5.3	47.1	41.1	35.1	29.1	23.1	-	43.2	5.8	43.2	39.0	33.1	27.1	21.2	-
	62	45.0	5.2	45.0	45.0	41.5	35.5	29.5	23.5	41.2	5.7	41.2	41.2	38.4	32.4	26.4	20.5
	57	46.7	5.3	46.7	46.7	41.3	35.3	29.3	23.3	42.0	6.0	42.0	42.0	36.9	31.0	25.0	19.1
1650	77	56.8	5.3	32.9	24.3	17.9	-	-	-	51.7	5.8	33.1	22.4	16.0	-	-	-
	72	52.3	5.3	40.1	33.7	27.2	20.8	-	-	47.4	5.8	38.1	31.7	25.3	18.8	-	-
	67	47.8	5.2	47.4	43.0	36.6	30.1	23.7	-	43.1	5.8	43.1	41.0	34.6	28.1	21.7	-
	62	45.0	5.2	45.0	45.0	43.2	36.7	30.3	23.8	41.0	5.7	41.0	41.0	40.1	33.7	27.2	20.8
	57	46.7	5.2	46.7	46.7	43.0	36.5	30.1	23.6	41.9	6.0	41.9	41.9	38.6	32.2	25.8	19.3
1800	77	56.8	5.3	36.6	25.5	18.6	-	-	-	51.5	5.8	37.3	23.6	16.7	-	-	-
	72	52.2	5.3	42.2	35.2	28.3	21.4	-	-	47.2	5.8	40.2	33.3	26.4	19.4	-	-
	67	47.7	5.2	47.7	45.0	38.0	31.1	24.2	-	43.0	5.7	43.0	43.0	36.0	29.1	22.2	-
	62	44.9	5.2	44.9	44.9	44.9	38.0	31.1	24.2	40.9	5.7	40.9	40.9	40.9	34.9	28.0	21.1
	57	46.7	5.2	46.7	46.7	44.7	37.8	30.9	24.0	41.7	6.0	41.7	41.7	40.3	33.4	26.5	19.6
1900	72	51.7	5.3	43.3	36.2	29.0	21.9	-	-	46.5	5.8	41.2	34.1	27.0	19.8	-	-
	67	47.3	5.2	47.3	45.9	39.0	31.9	24.7	-	42.3	5.7	42.3	42.3	36.9	29.8	22.7	-
	62	44.5	5.2	44.5	44.5	44.5	37.3	30.2	23.1	40.2	5.7	40.2	40.2	40.2	33.6	26.5	19.3
		57	46.2	5.2	46.2	46.2	45.2	38.1	30.9	23.8	41.0	6.0	41.0	41.0	40.3	33.2	26.1
2000	72	51.2	5.2	44.5	37.1	29.7	22.4	-	-	45.7	5.7	42.2	34.9	27.6	20.2	-	-
	67	46.8	5.2	46.8	46.8	40.0	32.6	25.2	-	41.6	5.7	41.6	41.6	37.7	30.4	23.1	-
	62	44.0	5.2	44.0	44.0	44.0	36.7	29.3	21.9	39.6	5.7	39.6	39.6	39.6	32.3	24.9	17.6
		57	45.7	5.2	45.7	45.7	45.7	38.4	31.0	23.7	40.4	6.0	40.4	40.4	40.4	33.0	25.7

1. These capacities are Net Capacities.

2. These ratings include the compressor, condenser fan and supply air blower motors.

Airflow Performance

Side Duct Application

DEQ024-060

Size (Tons)	Model	Mode	Thermostat Input	Speed Tap	CFM	External Static Pressure (Inch Water Gauge)									
						0.2	0.3	0.4	0.5	0.6	0.7	0.8	0.9	1.0	
						Watts	Watts	Watts	Watts	Watts	Watts	Watts	Watts	Watts	
024 (2.0)	DEQ	Cool	Y1	COOL-A	800	99	117	137	156	176	196	217	237	258	
			Y1	COOL-B	600	57	74	91	108	126	143	161	179	197	
			Y1	COOL-C	700	76	94	112	130	148	167	186	205	224	
			Y1	COOL-D	900	126	146	166	187	208	231	253	277	300	
		Heat	W1	HEAT-A	800	99	117	137	156	-	-	-	-	-	-
			W1	HEAT-B	720	80	98	116	135	-	-	-	-	-	-
			W1	HEAT-C	880	120	140	160	180	-	-	-	-	-	-
			W1	HEAT-D	1000	159	179	200	222	246	270	296	323	350	
030 (2.5)	DEQ	Cool	Y1	COOL-A	1000	159	179	200	222	246	270	296	323	350	
			Y1	COOL-B	925	129	148	169	190	211	233	256	280	304	
			Y1	COOL-C	1075	194	214	236	260	285	312	341	371	403	
			Y1	COOL-D	1150	233	254	277	302	330	360	392	427	463	
		Heat	W1	HEAT-A	1000	159	179	200	222	-	-	-	-	-	-
			W1	HEAT-B	900	120	139	159	180	-	-	-	-	-	-
			W1	HEAT-C	1100	206	227	249	274	-	-	-	-	-	-
			W1	HEAT-D	1000	159	179	200	222	-	-	-	-	-	-
036 (3.0)	DEQ	Cool	Y1	COOL-A	1200	261	283	306	333	362	394	429	467	507	
			Y1	COOL-B	1000	159	179	200	222	246	270	296	323	350	
			Y1	COOL-C	1100	206	227	249	274	300	328	357	389	422	
			Y1	COOL-D	1300	325	346	372	401	434	471	511	556	604	
		Heat	W1	HEAT-A	1200	261	283	306	333	-	-	-	-	-	-
			W1	HEAT-B	1080	196	217	239	263	-	-	-	-	-	-
			W1	HEAT-C	1275	308	330	355	383	-	-	-	-	-	-
			W1	HEAT-D	1200	261	283	306	333	-	-	-	-	-	-
042 (3.5)	DEQ	Cool	Y1	COOL-A	1400	338	383	426	468	509	549	589	627	664	
			Y1	COOL-B	1200	245	281	318	354	390	426	462	497	533	
			Y1	COOL-C	1300	290	330	370	409	447	485	523	560	596	
			Y1	COOL-D	1500	391	439	486	532	576	618	660	700	739	
		Heat	W1	HEAT-A	1225	256	293	330	367	-	-	-	-	-	-
			W1	HEAT-B	1100	203	237	270	304	-	-	-	-	-	-
			W1	HEAT-C	1350	314	356	397	438	-	-	-	-	-	-
			W1	HEAT-D	1225	256	293	330	367	-	-	-	-	-	-
048 (4.0)	DEQ	Cool	Y1	COOL-A	1600	408	461	512	562	610	657	703	747	790	
			Y1	COOL-B	1400	290	334	378	422	465	508	550	592	633	
			Y1	COOL-C	1500	349	397	445	492	537	582	626	669	711	
			Y1	COOL-D	1700	467	524	579	632	683	732	779	825	868	
		Heat	W1	HEAT-A	1600	408	461	512	562	610	657	-	-	-	-
			W1	HEAT-B	1440	313	359	405	450	494	537	-	-	-	-
			W1	HEAT-C	1760	503	562	619	674	726	777	-	-	-	-
			W1	HEAT-D	1600	408	461	512	562	610	657	-	-	-	-
060 (5.0)	DEQ	Cool	Y1	COOL-A	1500	404	438	475	512	555	597	644	692	728	
			Y1	COOL-B	1650	498	542	588	634	683	732	783	835	888	
			Y1	COOL-C	1800	590	643	696	750	805	860	916	973	1030	
			Y1	COOL-D	1900	654	715	775	836	895	955	1013	1072	-	
		Heat	W1	HEAT-A	1900	654	715	775	836	895	-	-	-	-	-
			W1	HEAT-B	1975	703	772	839	904	968	-	-	-	-	-
			W1	HEAT-C	2150	823	913	999	1079	1154	-	-	-	-	-
			W1	HEAT-D	2070	767	847	923	997	1066	-	-	-	-	-

Additional Static Resistance

Size (Tons)	Model	CFM	Wet Indoor Coil	Economizer ¹	Filter/Frame Kit	Electric Heat
024 (2.0)	DEQ	500	0.01	0.00	0.01	0.02
		600	0.01	0.00	0.02	0.03
		700	0.01	0.00	0.02	0.03
		800	0.01	0.01	0.02	0.03
		900	0.01	0.01	0.02	0.04
		1000	0.02	0.01	0.02	0.04
		1100	0.03	0.01	0.03	0.05
030 (2.5)	DEQ	700	0.01	0.00	0.02	0.03
		800	0.01	0.01	0.02	0.03
		900	0.01	0.01	0.02	0.04
		1000	0.02	0.01	0.02	0.04
		1100	0.03	0.01	0.03	0.05
		1200	0.04	0.02	0.03	0.06
036 (3.0)	DEQ	1300	0.07	0.03	0.17	-
		700	0.01	0.00	0.02	0.03
		800	0.01	0.01	0.02	0.03
		900	0.01	0.01	0.02	0.04
		1000	0.02	0.01	0.02	0.04
		1100	0.03	0.01	0.03	0.05
		1200	0.04	0.02	0.03	0.06
		1300	0.04	0.03	0.03	0.07
042 (3.5)	DEQ	1400	0.04	0.04	0.03	0.08
		1100	0.03	0.01	0.03	0.05
		1200	0.04	0.02	0.03	0.06
		1300	0.04	0.03	0.03	0.07
		1400	0.04	0.04	0.03	0.08
048 (4.0)	DEQ	1500	0.05	0.05	0.04	0.09
		1600	0.06	0.06	0.05	0.10
		1100	0.03	0.01	0.03	0.05
		1200	0.04	0.02	0.03	0.06
		1300	0.04	0.03	0.03	0.07
		1400	0.04	0.04	0.03	0.08
		1500	0.04	0.05	0.04	0.09
		1600	0.04	0.06	0.05	0.10
		1700	0.05	0.07	0.05	0.11
		1800	0.05	0.07	0.06	0.11
060 (5.0)	DEQ	1900	0.06	0.08	0.06	0.11
		2000	0.07	0.08	0.07	0.12
		1100	0.03	0.01	0.03	0.05
		1200	0.04	0.02	0.03	0.06
		1300	0.04	0.03	0.03	0.07
		1400	0.04	0.04	0.03	0.08
		1500	0.04	0.05	0.04	0.09
		1600	0.04	0.06	0.05	0.10
		1700	0.05	0.07	0.05	0.11
		1800	0.05	0.07	0.06	0.11

1. The pressure drop through the economizer is greater for 100% outdoor air than for 100% return air. If the resistance of the return air duct is less than 0.25 IWG, the unit will deliver less CFM during full economizer operation.

Electric Heat Minimum Supply Air

Size (Tons)	Model	Voltage	Minimum Supply Air (CFM)					
			Heater kW					
			5.0	7.5	10.0	15.0	20.0	25.0
024 (2.0)	DEQ	208/230-1-60	630	630	800	-	-	-
030 (2.5)	DEQ	208/230-1-60	630	630	800	800	-	-
036 (3.0)	DEQ	208/230-1-60	1070	1070	1070	1070	-	-
		208/230-3-60	1070	1070	1070	1070	-	-
		460-3-60	1070	1070	1070	1070	-	-
042 (3.5)	DEQ	208/230-1-60	1225	1225	1225	1225	-	-
048 (4.0)	DEQ	208/230-1-60	-	-	1200	1430	1430	1430
		208/230-3-60	-	-	1200	1430	1430	1430
		460-3-60	-	-	1200	1430	1430	1430
060 (5.0)	DEQ	208/230-1-60	-	-	1615	1615	1955	1955
		208/230-3-60	-	-	1615	1615	1955	1955
		460-3-60	-	-	1615	1615	1955	1955

Indoor Blower Specifications

Size (Tons)	Model	Motor				
		HP	RPM	Eff.	SF	Frame
024 (2.0)	DEQ	1/2	Variable	0.8	1.0	48
030 (2.5)	DEQ	1/2	Variable	0.8	1.0	48
036 (3.0)	DEQ	1/2	Variable	0.8	1.0	48
042 (3.5)	DEQ	3/4	Variable	0.8	1.0	48
048 (4.0)	DEQ	3/4	Variable	0.8	1.0	48
060 (5.0)	DEQ	1	Variable	0.8	1.0	48

Electric Heat Multipliers

Voltage		kW Capacity Multipliers ¹
Nominal	Applied	
240	208	0.75
	230	0.92
480	460	0.92

1. Electric heaters are rated at nominal voltage. Use this table to determine the electric heat capacity for heaters applied at lower voltages.

Sound Performance

Outdoor Sound Power Levels

Size (Tons)	Model	Sound Rating ¹ dB (A)	Octave Band Centerline Frequency (Hz)						
			125	250	500	1000	2000	4000	8000
024 (2.0)	DEQ	80	72	70	65	76	66	72	58
030 (2.5)	DEQ	79	66	67	67	76	75	66	57
036 (3.0)	DEQ	74	65	64	67	68	67	65	59
042 (3.5)	DEQ	74	64	65	68	69	63	59	57
048 (4.0)	DEQ	80	71	72	74	73	69	67	62
060 (5.0)	DEQ	80	68	71	74	73	72	72	60

1. Rated in accordance with AHRI 270 standard.

Electrical Data

DEQ024-060 Cooling Only With/Without Electric Heat

Size (Tons)	Volt	Compressors (each)			OD Fan Motors (each)	Supply Blower Motor	Electric Heat Option				MCA ¹ (Amps)	Max Fuse ² / Breaker ³ Size (Amps)
		RLA	LRA	MCC			FLA	FLA	Model	kW		
024 (2.0)	208/230-1-60	8.3	43	13	1.2	4.3	None	-	-	-	15.9	20
							2NH04500506	3.8 / 5	1	18.1 / 20.8	27.9 / 31.4	30 / 35
							2NH04500706	5.6 / 7.5	2	27.1 / 31.3	39.2 / 44.4	40 / 45
							2NH04501006	7.5 / 10	2	36.1 / 41.7	50.5 / 57.5	60 / 60
030 (2.5)	208/230-1-60	13.1	74	21	1.2	4.3	None	--	-	--	21.9	30
							2NH04500506	3.8 / 5	1	18.1 / 20.8	27.9 / 31.4	30 / 35
							2NH04500706	5.6 / 7.5	2	27.1 / 31.3	39.2 / 44.4	40 / 45
							2NH04501006	7.5 / 10	2	36.1 / 41.7	50.5 / 57.5	60 / 60
							2NH04501506	11.3 / 15	2	54.2 / 62.5	73.1 / 83.5	80 / 90
036 (3.0)	208/230-1-60	14.7	74	23	1.2	4.3	None	-	-	-	23.9	30
							2NH04500506	3.8 / 5	1	18.1 / 20.8	27.9 / 31.4	35 / 35
							2NH04500706	5.6 / 7.5	2	27.1 / 31.3	39.2 / 44.4	40 / 45
							2NH04501006	7.5 / 10	2	36.1 / 41.7	50.5 / 57.5	60 / 60
							2NH04501506	11.3 / 15	2	54.2 / 62.5	73.1 / 83.5	80 / 90
	208/230-3-60	9.1	68	14	1.2	4.3	None	-	-	-	16.9	25
							2NH04501025	7.5 / 10	1	20.8 / 24.1	31.4 / 35.4	35 / 40
							2NH04501525	11.3 / 15	1	31.3 / 36.1	44.5 / 50.5	45 / 60
							None	-	-	-	8.6	15
							2NH04501046	10	1	12	17.8	20
460-3-60	4.5	34	7	0.8	2.2	2NH04501546	15	1	18	25.3	30	
						None	-	-	-	27.8	35	
						2NH04500506	3.8 / 5	1	18.1 / 20.8	31.1 / 34.5	40 / 40	
042 (3.5)	208/230-1-60	15.7	88	25	1.4	6.8	2NH04500706	5.6 / 7.5	2	27.1 / 31.3	42.4 / 47.6	45 / 50
							2NH04501006	7.5 / 10	2	36.1 / 41.7	53.6 / 60.6	60 / 70
							2NH04501506	11.3 / 15	2	54.2 / 62.5	76.2 / 86.6	80 / 90
							None	-	-	-	27.8	35
048 (4.0)	208/230-1-60	21.8	117	34	1.7	6.8	None	---	---	---	35.8	45
							2NH04501006	7.5 / 10	2	36.1 / 41.7	53.6 / 60.6	60 / 70
							2NH04501506	11.3 / 15	2	54.2 / 62.5	76.2 / 86.6	80 / 90
							2NH04502006	15 / 20	2	72.2 / 83.3	98.8 / 112.7	100 / 125
							2NH04502506	18.8 / 25	2	90.3 / 104.2	121.3 / 138.7	125 / 150
	208/230-3-60	13.7	83	21	1.7	6.8	None	---	---	---	25.6	35
							2NH04501025	7.5 / 10	1	20.8 / 24.1	34.6 / 38.6	35 / 40
							2NH04501525	11.3 / 15	1	31.3 / 36.1	47.6 / 53.6	50 / 60
							2NH04502025	15 / 20	2	41.7 / 48.1	60.6 / 68.6	70 / 70
							2NH04502525	18.8 / 25	2	52.1 / 60.1	73.7 / 83.7	80 / 90
460-3-60	6.2	41	10	1.0	3.4	None	---	---	---	12.2	15	
						2NH04501046	10	1	12	19.3	20	
						2NH04501546	15	1	18	26.8	30	
						2NH04502046	20	2	24.1	34.3	35	
						2NH04502546	25	2	30.1	41.8	45	
060 (5.0)	208/230-1-60	25.0	134	39	2.8	9.1	None	-	-	-	43.2	60
							2NH04501006	7.5 / 10	2	36.1 / 41.7	56.5 / 63.5	60 / 70
							2NH04501506	11.3 / 15	2	54.2 / 62.5	79.1 / 89.5	80 / 90
							2NH04502006	15 / 20	2	72.2 / 83.3	101.7 / 115.5	110 / 125
							2NH04502506	18.8 / 25	2	90.3 / 104.2	124.2 / 141.6	125 / 150
	208/230-3-60	20.2	110	25	2.8	9.1	None	-	-	-	37.2	45
							2NH04501025	7.5 / 10	1	20.8 / 24.1	37.4 / 41.4	45 / 50
							2NH04501525	11.3 / 15	1	31.3 / 36.1	50.5 / 56.5	60 / 60
							2NH04502025	15 / 20	2	41.7 / 48.1	63.5 / 71.5	70 / 80
							2NH04502525	18.8 / 25	2	52.1 / 60.1	76.5 / 86.6	80 / 90
460-3-60	7.0	52	11	1.4	4.6	None	-	-	-	14.8	20	
						2NH04501046	10	1	12	20.8	25	
						2NH04501546	15	1	18	28.3	30	
						2NH04502046	20	2	24.1	35.8	40	
						2NH04502546	25	2	30.1	43.3	45	

1. Minimum Circuit Ampacity.
2. Maximum Over Current Protection per standard UL 1995.
3. Fuse or HACR circuit breaker size installed at factory or field installed.

Typical DEQ060 Cooling Only 208/230-1-60 volt Wiring Diagram

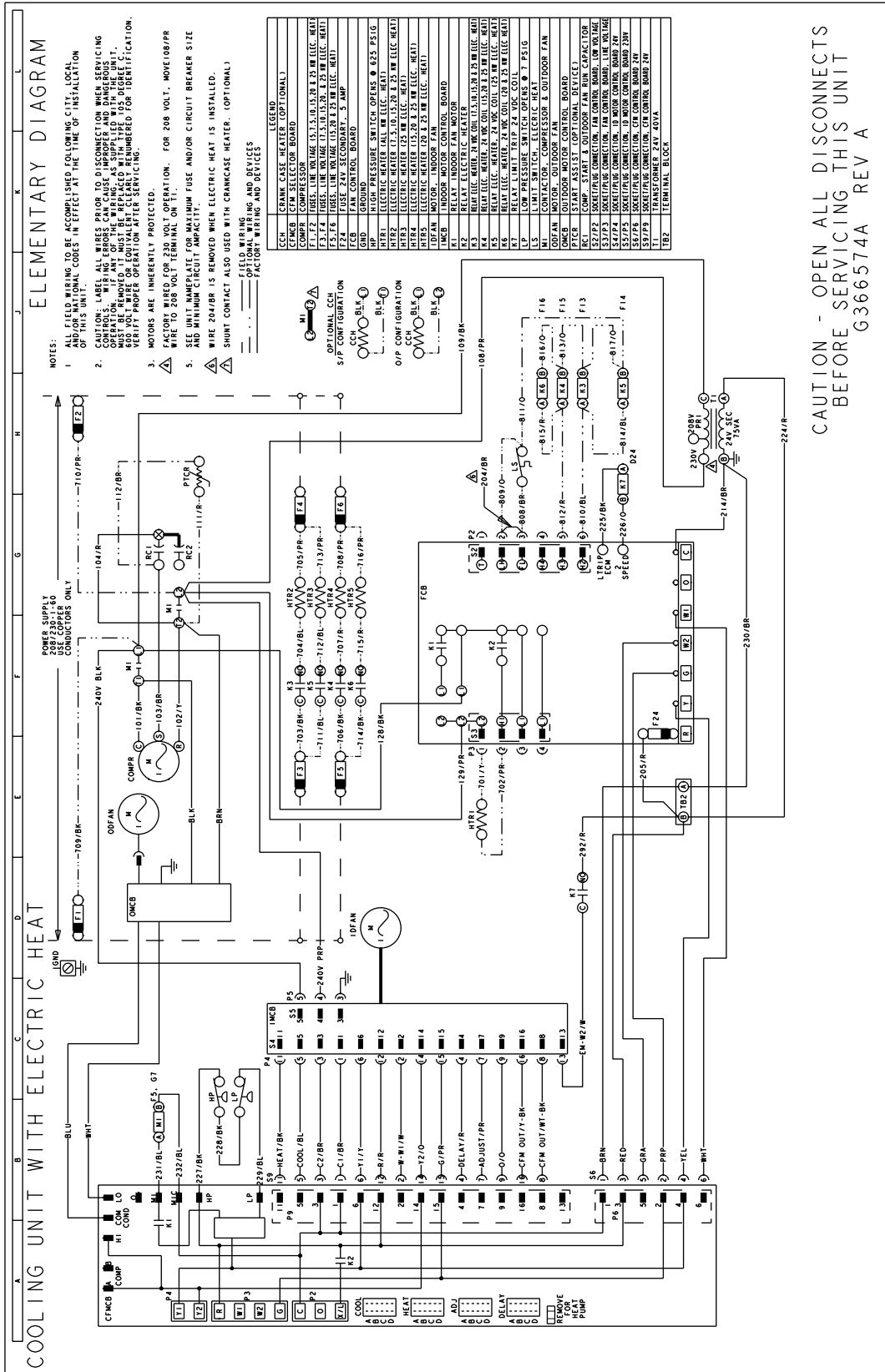

Typical DEQ036, 048 Cooling Only 208/230-3-60 volt Wiring Diagram

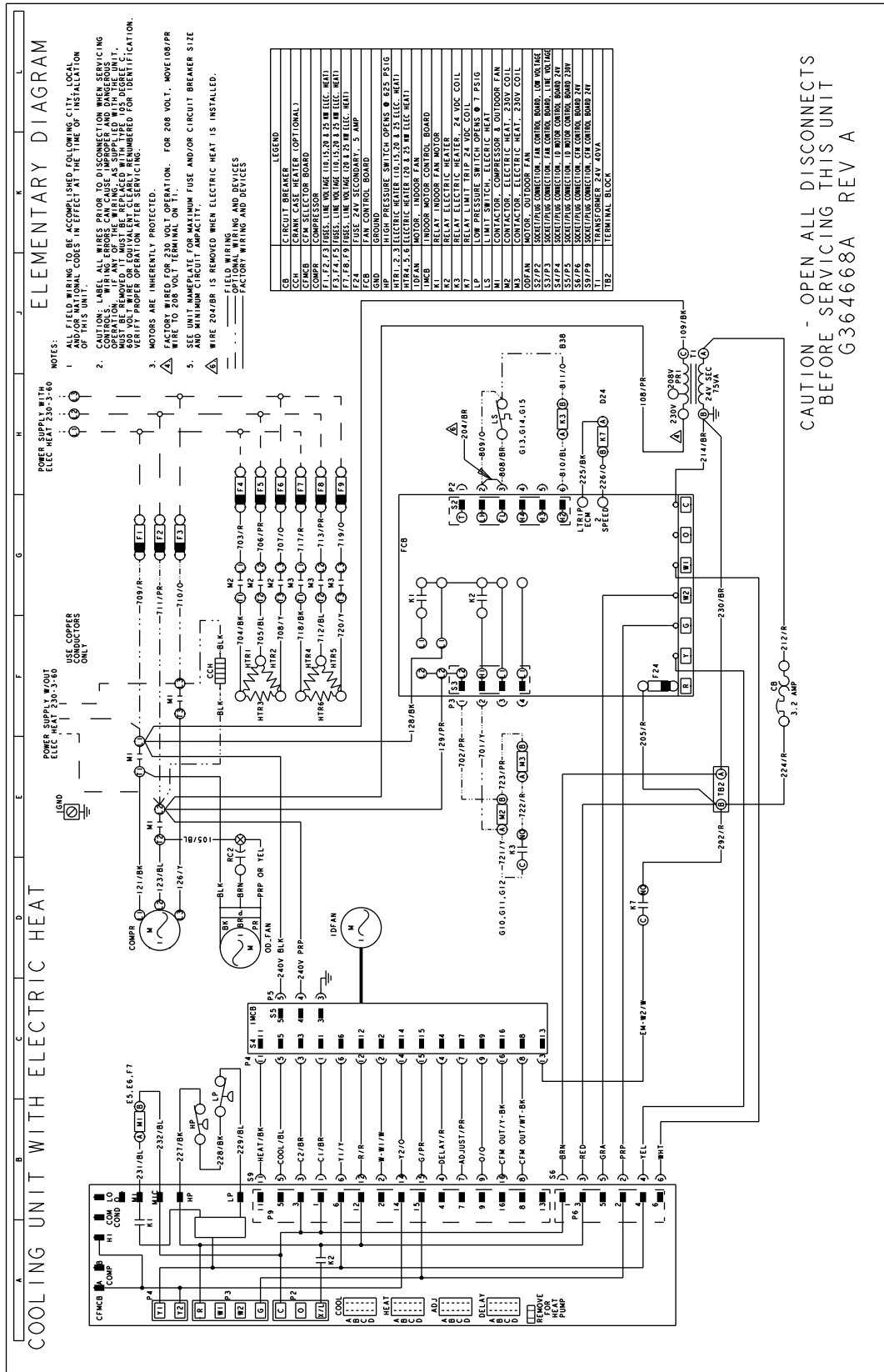

Weights and Dimensions

Unit 4 Point Load Weight

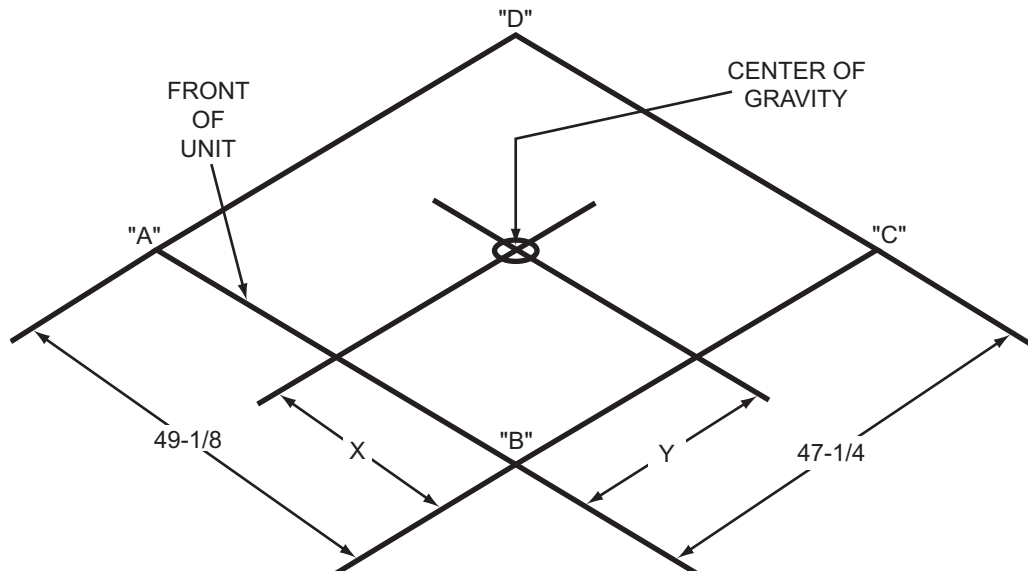

Size (Tons)	Model	Weight (lbs.)		Center of Gravity		4 Point Load Location (lbs.)			
		Shipping	Operating	X	Y	A	B	C	D
024 (2.0)	DEQ	351	346	22.25	25	94	82	79	91
030 (2.5)	DEQ	391	386	22.25	25	105	92	88	101
036 (3.0)	DEQ	401	396	22.25	25	108	94	91	104
042 (3.5)	DEQ	411	406	22.25	25	110	96	93	106
048 (4.0)	DEQ	445	440	22.25	25	120	104	101	115
060 (5.0)	DEQ	457	452	22.25	25	123	107	103	119

Unit Accessory Weights

Unit Accessory	Model	Weight (lbs.)	
		Shipping	Operating
Add Economizer	All	45	40
Add Electric Heat ¹	All	13	12

1. Weight given is for the maximum heater size available (25 kW).

Cooling Only Unit Dimensions

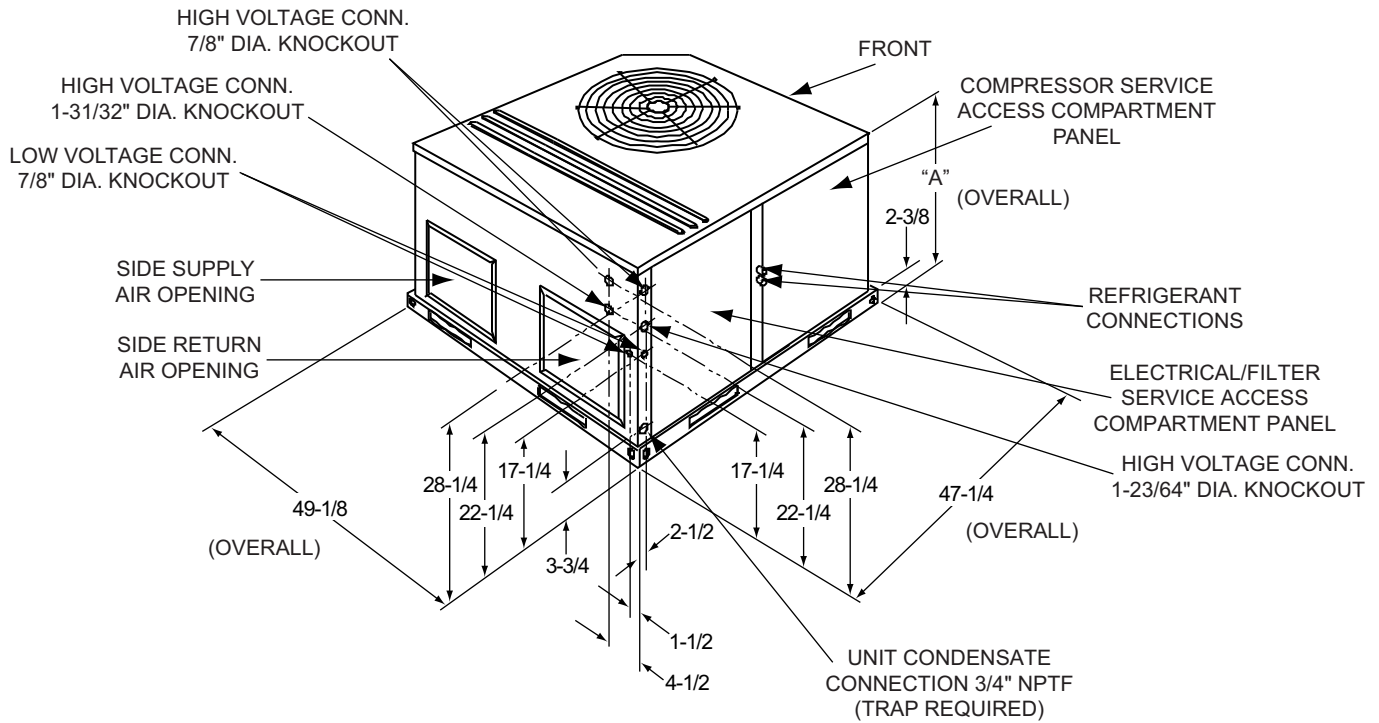

Cooling Only Unit Dimensions

Unit Size	Dimensions
	"A"
024, 030, 036	33-1/2
042, 048, 060	41-1/2

Cooling Only Unit Clearances

Direction	Distance (in.)	Direction	Distance (in.)
Top ¹	36	Right	24
Front	12	Left	24
Rear	0	Bottom ^{2 3}	0

1. Units must be installed outdoors. Over hanging structure or shrubs should not obscure condenser air discharge outlet.
2. Units may be installed on combustable floors made from wood or class A, B or C roof covering materials.
3. Minimum Clearance of 1inch all sides of supply air duct for the first 3 foot of duct for 20 & 25 kW., zero inches there after. For all other heaters, zero inch clearance all sides for entire length of duct.

Note: For units applied with a roof curb, the minimum clearance may be reduced from 1 inch to 1/2 inch between combustable roof curb material and this supply air duct.

Unit Dimensions Front and Bottom

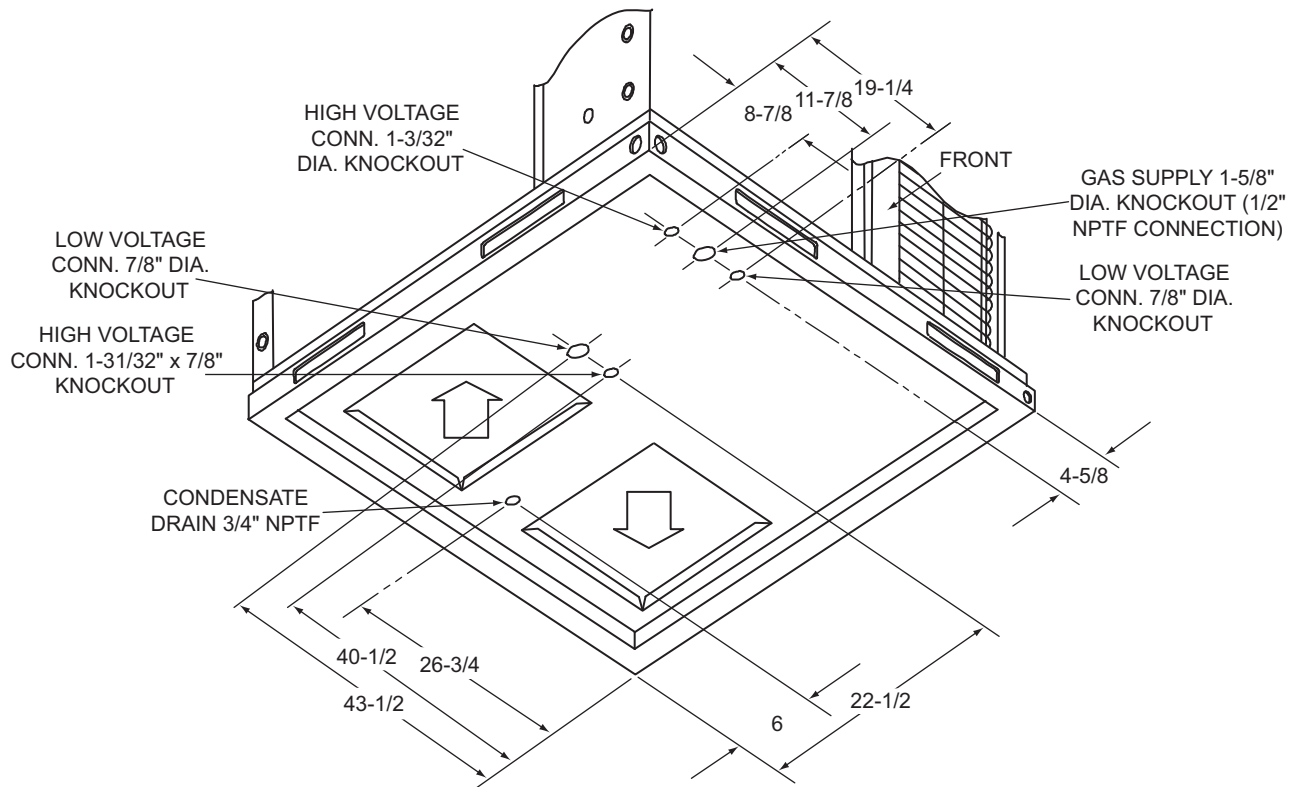

Unit Dimensions Back and Bottom

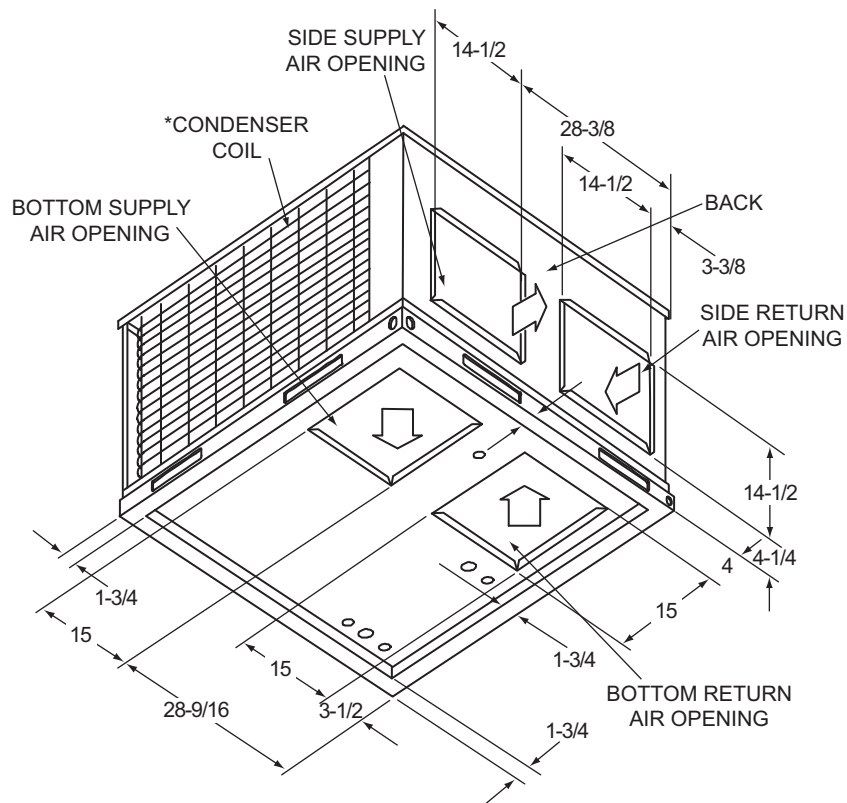

Unit Typical Duct Applications

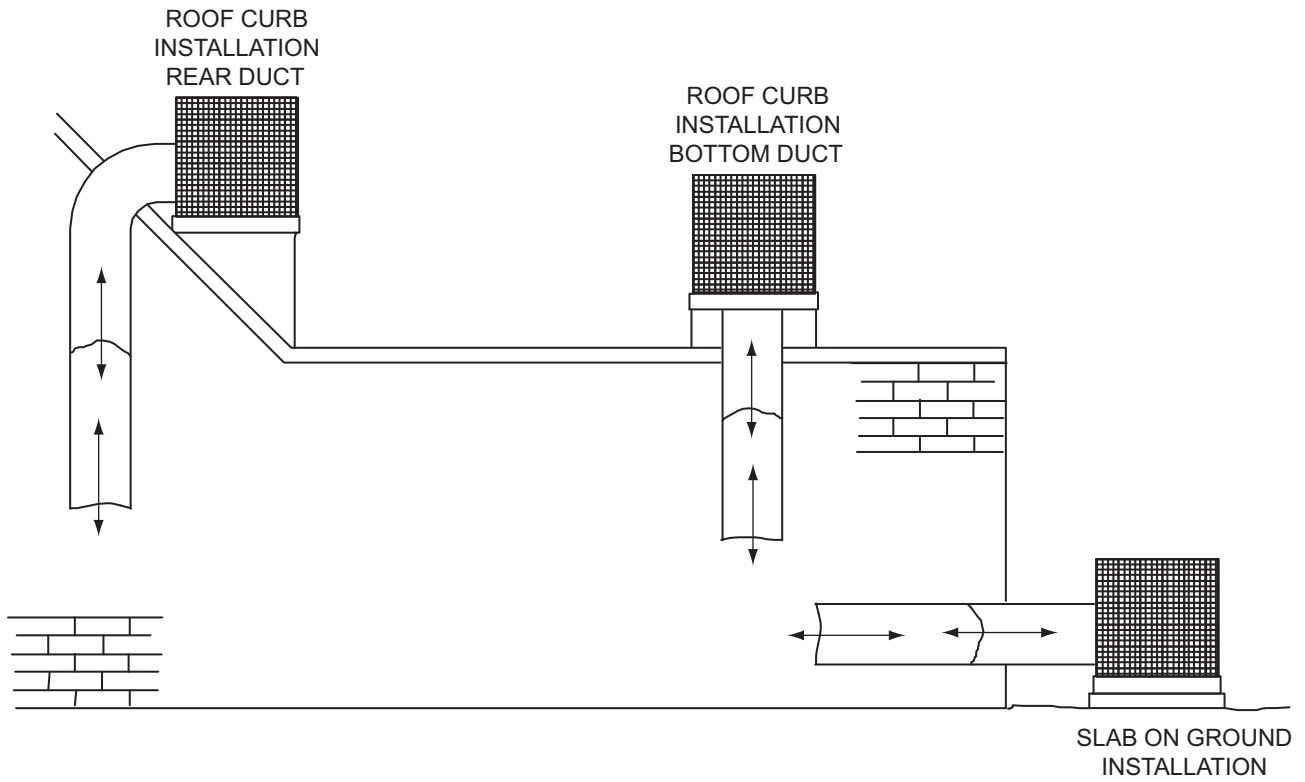

Unit Typical Slab on Ground Installation

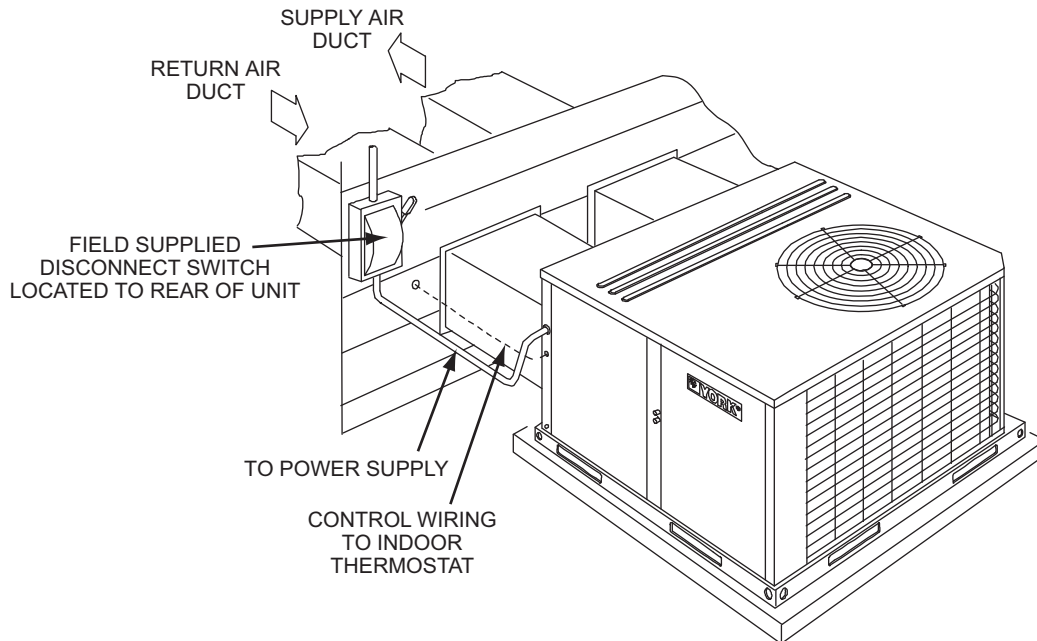

Unit Typical Roof Curb Installation

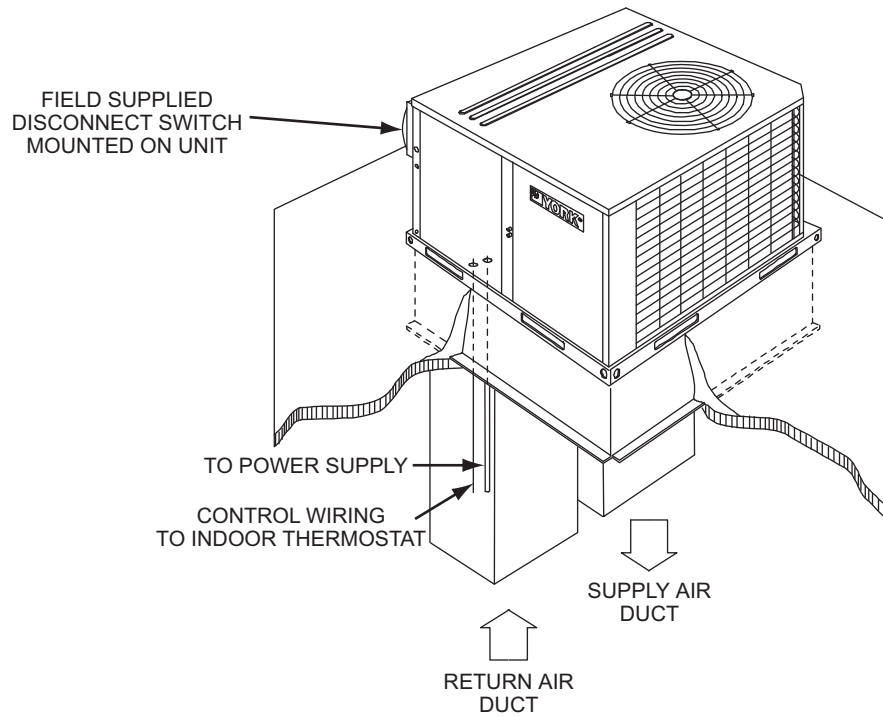

Unit Accessory Dimensions

Roof Curb¹

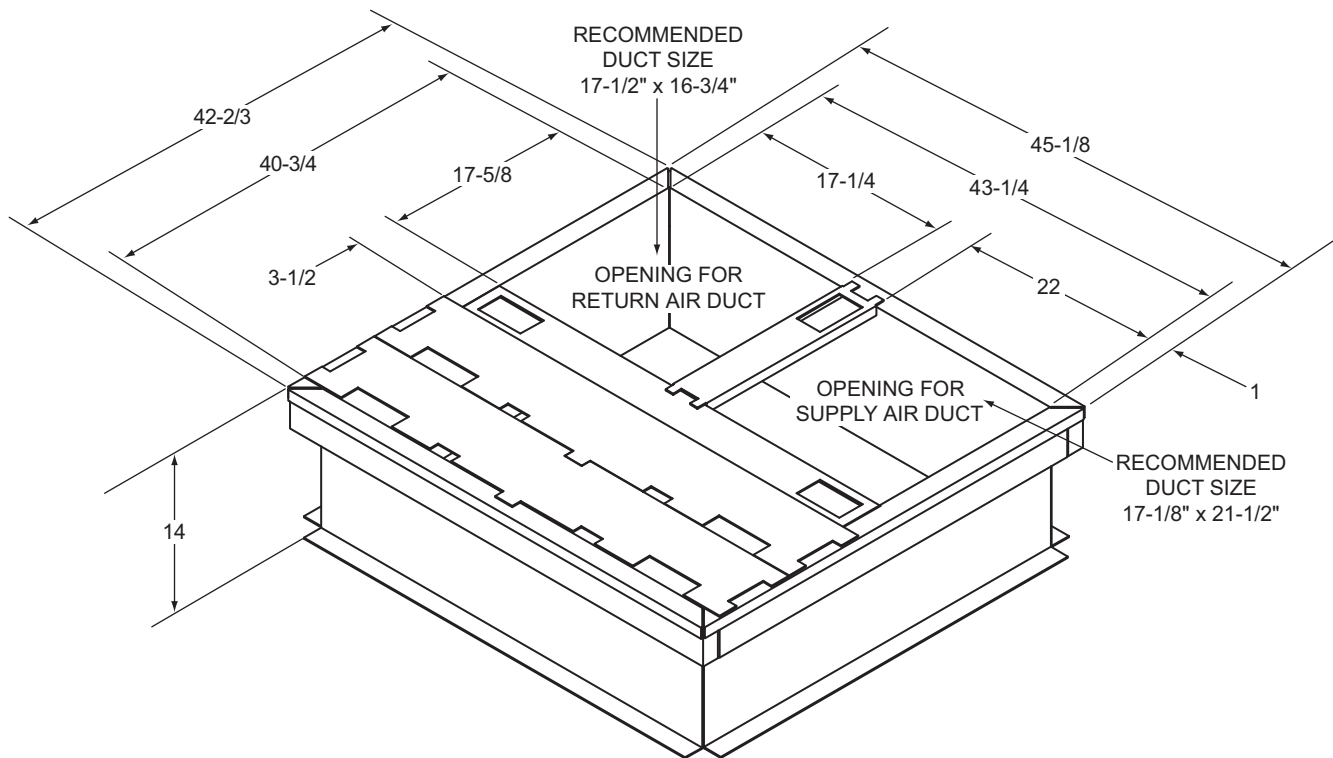

1. 8" Roof Curb also available.

Roof Curb Cross Section

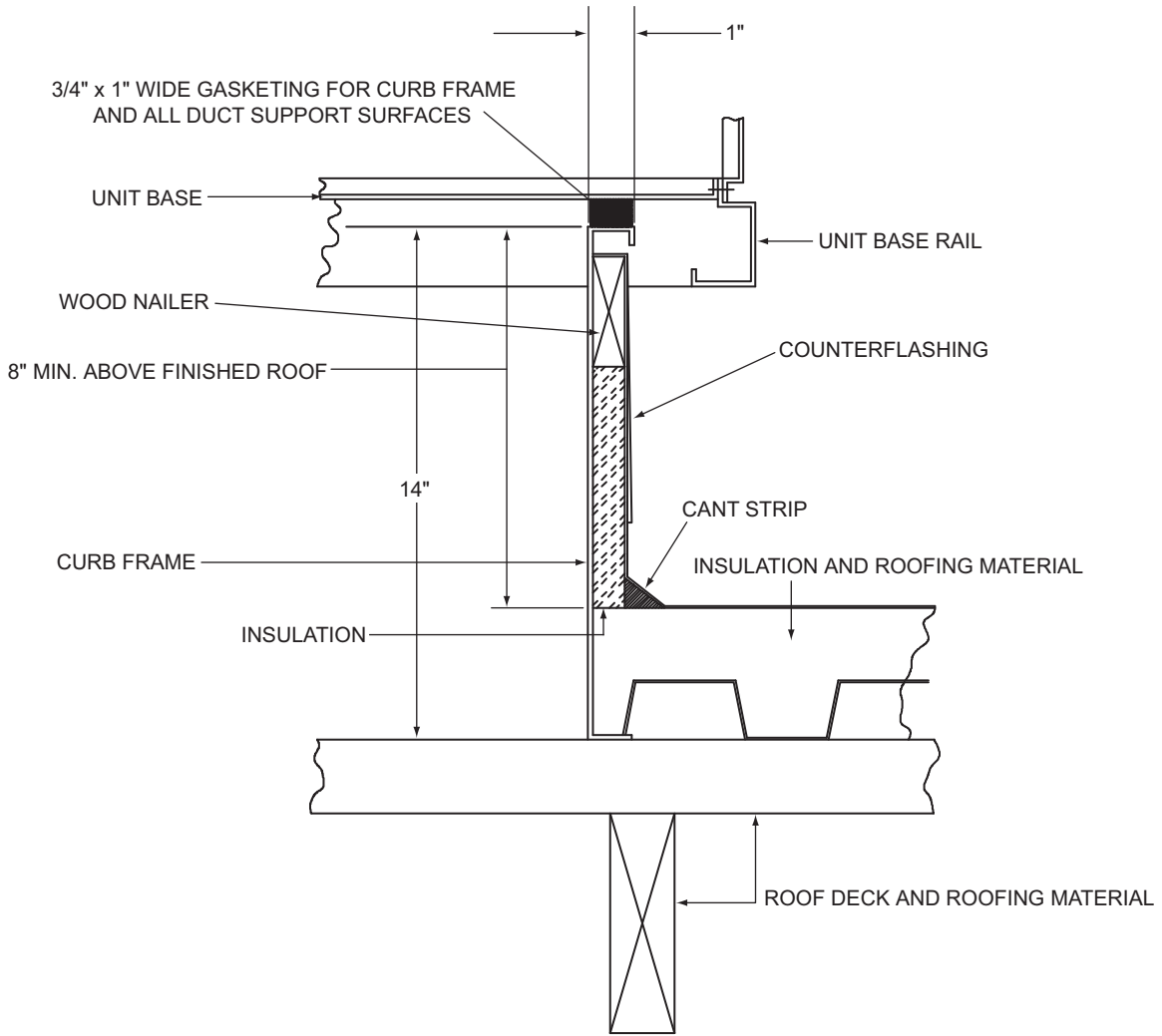

Subject to change without notice. Printed in U.S.A.
 Copyright © 2013 by Johnson Controls, Inc. All rights reserved.

718433-YTG-D-0113
 Supersedes: 718433-YTG-C-1112

Johnson Controls Unitary Products
 5005 York Drive
 Norman, OK 73069